

**XEROX**

**Document FaxCentre 165**

**and**

**Document WorkCentre 165c**

**SERVICE MANUAL**

Part Number : 602E48370



## PREFACE

This manual is intended for service engineers responsible for installing, servicing and repairing the facsimile machines described herein. The manual consists of thirteen chapters which describe:

- Chapter 1: the **General Features** and **Technical Specifications**
- Chapter 2: the facsimile machine's **Internal and external structure**
- Chapter 3: the **Installation and setup** procedures
- Chapter 4: how to set the **Software Parameters**
- Chapter 5: the **Diagnostic and testing** procedures
- Chapter 6: the **Settings and adjustments**
- Chapter 7: the **Maintenance and replacement** procedures
- Chapter 8: the **Optional devices**
- Chapter 9: the **Installation of the LinkFax 8 module in Windows 95 environment**
- Chapter 10: the **User Guide of the LinkFax 8 module in Windows 95 environment**
- Chapter 11: the **Installation of the LinkFax 8 module in Windows 3.1x environment**
- Chapter 12: the **User Guide of the LinkFax 8 module in Windows 3.1x environment**
- Chapter 13: the **Spares List**

**FIRST EDITION:** April 1998

**REFERENCES:** User Manual

# CONTENTS

<b>1.</b>	<b>INTRODUCTION .....</b>	<b>1-1</b>
<b>1.1</b>	<b>MAIN FEATURES .....</b>	<b>1-1</b>
<b>1.2</b>	<b>TECHNICAL SPECIFICATIONS .....</b>	<b>1-2</b>
<b>1.3</b>	<b>QUICK REFERENCE GUIDE .....</b>	<b>1-5</b>
1.3.1	Sending a Fax .....	1-5
1.3.2	Receiving a Fax .....	1-5
1.3.3	Using the Facsimile Machine as a Photocopier .....	1-5
<b>2.</b>	<b>GENERAL DESCRIPTION.....</b>	<b>2-1</b>
<b>2.1</b>	<b>EXTERNAL PARTS.....</b>	<b>2-1</b>
2.1.1	Console .....	2-2
2.1.2	Functions of the console keys .....	2-3
<b>2.2</b>	<b>ELECTROMECHANICAL PARTS.....</b>	<b>2-6</b>
2.2.1	Motors .....	2-6
2.2.2	Sensors .....	2-7
2.2.3	Speaker .....	2-8
<b>2.3</b>	<b>ELECTRONIC PARTS .....</b>	<b>2-9</b>
2.3.1	General Block Diagram .....	2-10
2.3.2	Block Diagram of the Motherboard .....	2-11
2.3.3	Block Diagram of the Network Control Unit Board .....	2-14
2.3.4	Block Diagram of the Power Supply Board .....	2-15
2.3.6	Printer Unit .....	2-17
<b>3.</b>	<b>INSTALLATION AND INITIALIZATION PROCEDURES .....</b>	<b>3-1</b>
<b>3.1</b>	<b>PRELIMINARY OPERATIONS.....</b>	<b>3-1</b>
3.1.1	Unpacking the Facsimile Machine .....	3-1
3.1.2	Connecting to the Telephone Line .....	3-2
3.1.3	Connecting the Power Cord .....	3-4
3.1.4	Installing the Print Head .....	3-4
3.1.5	Inserting the Output Trays .....	3-9
3.1.6	Loading Paper .....	3-10
3.1.7	Feeding special papers manually on the LinkFax model .....	3-10

<b>3.2</b>	<b>INSTALLING AND SETTING UP THE MACHINE.....</b>	<b>3-12</b>
3.2.1	Organization of the Installation and Setup Parameters .....	3-12
3.2.2	Setting the Country Parameters .....	3-15
3.2.3	Storing the User's Number and Name .....	3-16
3.2.4	Setting Up the Telephone Line .....	3-17
3.2.5	Completing Installation .....	3-19
3.2.6	Resetting the Fax Machine .....	3-19
<b>4.</b>	<b>SERVICE SWITCHES.....</b>	<b>4-1</b>
<b>4.1</b>	<b>SERVICE SWITCH TABLES .....</b>	<b>4-3</b>
<b>5.</b>	<b>DIAGNOSTICS .....</b>	<b>5-1</b>
<b>5.1</b>	<b>SELF-DIAGNOSTICS .....</b>	<b>5-1</b>
5.1.1	Description of the Self-Diagnostic Program .....	5-2
<b>5.2</b>	<b>ERROR CODES .....</b>	<b>5-3</b>
5.2.1	Meaning of Protocol Signal Codes .....	5-4
5.2.2	Meaning of Error Codes .....	5-6
5.2.3	Printing the Communication Protocol .....	5-9
5.2.4	Printing the Counters .....	5-11
<b>5.3</b>	<b>REPORTS .....</b>	<b>5-12</b>
5.3.1	Transmission Report (LAST TX REPORT) .....	5-12
5.3.2	Broadcast Transmission Report (LAST BROAD. REP.) .....	5-14
5.3.3	Activity Report (ACTIVITY REPORT) .....	5-14
5.3.4	Power Failure Report .....	5-15
<b>5.4</b>	<b>REMOTE DIAGNOSTICS.....</b>	<b>5-16</b>
5.4.1	Enabling the Facsimile Machine as a "Slave Station" .....	5-16
<b>6.</b>	<b>SYSTEM TEST AND ADJUSTMENTS.....</b>	<b>6-1</b>
<b>6.1</b>	<b>SYSTEM TEST .....</b>	<b>6-1</b>
6.1.1	ALIGNMENT TEST .....	6-2
6.1.2	NOZZLES TEST .....	6-4
6.1.3	CLEANING .....	6-6
6.1.4	PRINT CHART .....	6-7
6.1.5	ASF TEST .....	6-9
6.1.6	ADF TEST .....	6-9
6.1.7	LOAD DEFAULT .....	6-10

6.1.8	SCANNER SHADING .....	6-10
6.1.9	CARRIAGE TEST .....	6-11
<b>6.2</b>	<b>CHECKS AND ADJUSTMENTS.....</b>	<b>6-12</b>
6.2.1	Checking the Direct Voltages .....	6-12
<b>6.3</b>	<b>ADJUSTING THE CCD .....</b>	<b>6-13</b>
6.3.1	Preparing for the CCD Adjustment .....	6-13
6.3.2	Checking the Alignment of the CCD Board .....	6-14
6.3.3	Checking the Lens Focus .....	6-16
6.3.4	Checking that the Document and the CCD are centred .....	6-17
<b>7.</b>	<b>MAINTENANCE AND REPLACEMENT PROCEDURES .....</b>	<b>7-1</b>
<b>7.1</b>	<b>MAINTENANCE .....</b>	<b>7-1</b>
7.1.1	OUT OF INK Message .....	7-1
7.1.2	Replacing the rechargeable Ink Cartridge .....	7-2
7.1.3	Replacing the Print Head .....	7-3
7.1.4	Cleaning the Print Head .....	7-3
7.1.5	Cleaning the Electrical Contacts .....	7-4
7.1.6	Cleaning the Print Head Cleaning Pad .....	7-5
7.1.7	Cleaning the Optical Unit .....	7-6
<b>7.2</b>	<b>DISASSEMBLY AND REPLACEMENT PROCEDURES.....</b>	<b>7-10</b>
7.2.1	Wirings .....	7-10
7.2.2	Removing the Casing .....	7-12
7.2.3	Removing the Power Supply/NCU Assembly .....	7-13
7.2.4	Removing the Power Supply and NCU Boards .....	7-15
7.2.5	Removing the Motherboard .....	7-16
7.2.6	Removing the Console .....	7-18
7.2.7	Removing the Console Board .....	7-19
7.2.8	Removing the Display .....	7-19
7.2.9	Removing the Scanner Unit .....	7-20
7.2.10	Removing the CCD Board .....	7-21
7.2.11	Removing the LED Array .....	7-21
7.2.12	Removing the Printer Unit .....	7-22
7.2.13	Removing the Carriage, Paper and Ink Drain Motors .....	7-23
7.2.14	Removing the Scanner Motor .....	7-24
7.2.15	Removing the Print Carriage .....	7-24
<b>8.</b>	<b>OPTIONAL DEVICES .....</b>	<b>8-1</b>
<b>8.1</b>	<b>SETTING UP A BACK TO BACK CONNECTION .....</b>	<b>8-2</b>

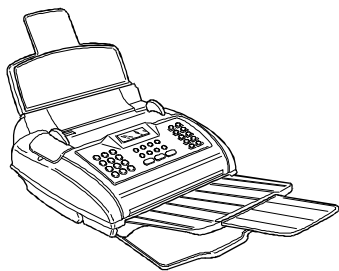
8.2	CONNECTING A TELEPHONE ANSWERING DEVICE.....	8-2
8.3	CONNECTING A TELEPHONE EXTENSION.....	8-3
8.4	HANDSET .....	8-4
9.	INSTALLATION OF THE LINKFAX 8 MODULE IN WINDOWS 95 ENVIRONMENT.....	9-1
10.	USER GUIDE OF THE LINKFAX 8 MODULE IN WINDOWS 95 ENVIRONMENT.....	10-1
11.	INSTALLATION OF THE LINKFAX 8 MODULE IN WINDOWS 3.1X ENVIRONMENT.....	11-1
12.	USER GUIDE OF THE LINKFAX 8 MODULE IN WINDOWS 3.1X ENVIRONMENT.....	12-1
13.	SPARE PARTS LISTINGS.....	13-1

# 1. INTRODUCTION

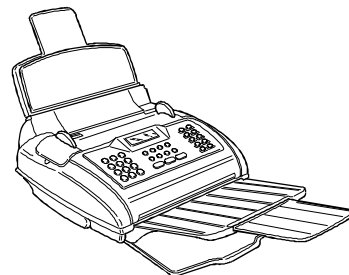
The two models referred to in this manual are desktop facsimile machines with a bubble ink jet printing system which complies with the ITU-TS G3 standard for document transmission and reception.

The most suitable factor to distinguish between the two models, similar in appearance, is the possibility of using a monochrome print head only or both monochrome and colour print heads.

The colour model, once connected to a PC equipped with the **LinkFax 8** software communication module, can be transformed into a **multifunctional product** able to perform both **printer** and **scanner** functions in addition to the facsimile traditional features. The colour print head must be used only for printing purposes. All standard facsimile functions require a monochrome print head. In this manual, the two models are referred to as follows:



**standard** model (monochrome)



**LinkFax** model (colour)

## 1.1 MAIN FEATURES

- **Bubble inkjet printing**

The facsimile machine prints on plain paper (standard model) or special paper (LinkFax model) in various formats (A4, Letter, Legal).

- **Memory capacity**

The facsimile machine has a memory which enables operations such as *One-touch Dialling*, *Speed Code Dialling*, *Broadcasting Transmission*, *Delayed Transmission* and *Substitute Reception*, as well as the storage of parameters, data and documents. This memory is powered by a backup battery in the event of a power failure.

- **Half tones**

In the scanning of documents, a scale of 64 half tones can be used for a higher



quality reproduction of photographs and pictures.

- **Automatic document feeder (ADF)**

This device enables up to 10 sheets of A4, A5, Letter US or Legal paper, with a maximum thickness of 0.1 mm/sheet, to be fed in automatically.

- **Telephone answering device (TAD)**

The model without a built-in TAD can be connected to an external one.

## 1.2 TECHNICAL SPECIFICATIONS

<b>Physical characteristics</b>	
Type	Desktop transceiver
Dimensions (L, D, H)	324 x 325 (+ 170 <sup>1</sup> + 118 <sup>2</sup> ) x 230 (+ 60 <sup>2</sup> )mm
Weight	6.3 kg
<b>Operator console</b>	
Display	2 lines of 16 characters
Keypad	<ul style="list-style-type: none"> <li>- 11 function keys of which 7 are dual function</li> <li>- 12 dual-function keys for normal dialling and user name setting</li> <li>- 10 one-touch dialling keys</li> <li>- 1 error LED</li> </ul>
<b>Power supply</b>	
Operating range	220-240V, 50/60Hz
Average consumption	11W (in standby); less than 30W (copying)
<b>Communication characteristics</b>	
Type of connection	Public telephone network (PSTN) or private branch exchange (PBX)
Compatibility	ITU-TS G3 standard
Type of modulation	CCITT V29 / V27ter
Transmission speed	2400 / 4800 / 7200 / 9600 bps

(<sup>1</sup>) with the document output tray

(<sup>2</sup>) with extension



Type of communication	Half duplex
Coding methods	MH, MR
Transmission time	About 15 s for ITU-TS test sheet n°1 (Slerexe Letter) at 9600 bps in standard resolution
<b>Scanner</b>	
Scanning system	CCD (Charge Coupled Device)
Resolution	Vertical: 3.85 (standard) / 7.7 (fine) lines/mm Horizontal: 8 dots/mm
Document size (width x length)	From 148 x 105 mm (minimum length) to 216 x 2000 mm (maximum length)
Actual scanning area	Horizontal: 210 mm Vertical: within 4 mm of the edge of the document
Automatic document feeder (ADF)	Capacity: 10 sheets of A4 / Letter US / Legal format (thickness max 0.1 mm/sheet) Thickness of sheets: min 0.06 mm, max 0.12 mm
Half tones	The facsimile machine can emphasize the contrast of text areas and reproduce pictures with 64 half tones.
Contrast	Three levels are handled: dark, normal and light
<b>Printer</b>	
Printing method	Bubble ink jet on plain paper (standard model) or special paper (LinkFax model)
Printing speed	ITU-TS test sheet n°1 (Slerexe Letter) / about 40 s
Automatic sheet feeder	Capacity: 80 sheets of A4 / Letter US / Legal format (weight 70-90g/m <sup>2</sup> )
Print resolution	200 x 100 / 200 dpi
Actual printing area	208 x 290 (A4) / 273 (Letter US) / 349 (Legal) mm
<b>Memory</b>	
Capacity	512 kbytes (about 360 kbytes as user memory) powered by a backup battery

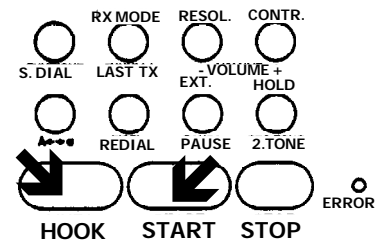
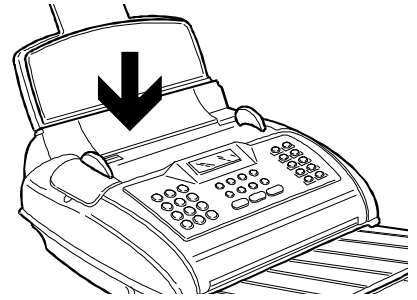


<p><b>Dialling</b></p> <p>Dialling mode</p> <p>Dialling on facsimile machine</p> <p>Redialling</p> <p>One-touch dialling</p> <p>Speed code dialling</p> <p>Delayed transmission</p> <p>Broadcasting transmission</p>	<p>Pulse and tone</p> <p>The number can be dialled directly on the facsimile machine's keypad</p> <p>A number can be redialled in automatic or manual mode</p> <p>There are 10 one-touch dialling keys</p> <p>There are 32 memory locations, each of which may be assigned a facsimile ID</p> <p>A document can be sent automatically at a preset time</p> <p>A document may be sent automatically to several correspondents (max 10).</p>
<p><b>Other features</b></p> <p>Automatic reception</p> <p>Polling</p> <p>Reports</p>	<p>The facsimile machine can be set to receive a document automatically</p> <p>Polling reception and free polling transmission features are available</p> <p>Various kinds of reports may be printed (transmission, activity, etc.)</p>
<p><b>Environmental conditions</b></p> <p>Temperature</p> <p>Relative humidity</p>	<p>Operating: from 5°C to 35°C Storage: from 0°C to +45°C Transport: from -15°C to +45°C</p> <p>Operating: from 15% to 85 % (without condensation) Storage: from 15% to 85 % (without condensation) Transport: from 5% to 95 % (without condensation)</p>

## 1.3 QUICK REFERENCE GUIDE

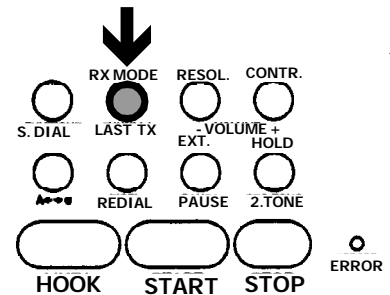
### 1.3.1 Sending a Fax

1. Insert the document into the automatic document feeder.
2. Press the **HOOK** key and dial the correspondent's number on the *numeric keypad*.
3. Wait for the answering tone from the correspondent's machine and then press **START**.



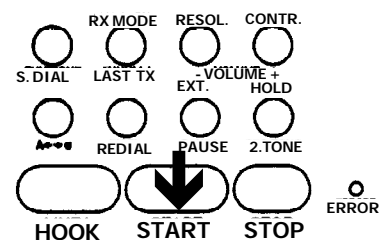
### 1.3.2 Receiving a Fax

1. The facsimile machine is normally set for *automatic reception*: the message AUTOMATIC RX is displayed.
2. If you want to receive a fax in manual mode, press the **RX MODE** key: the message MANUAL RX will be displayed.



### 1.3.3 Using the Facsimile Machine as a Photocopier

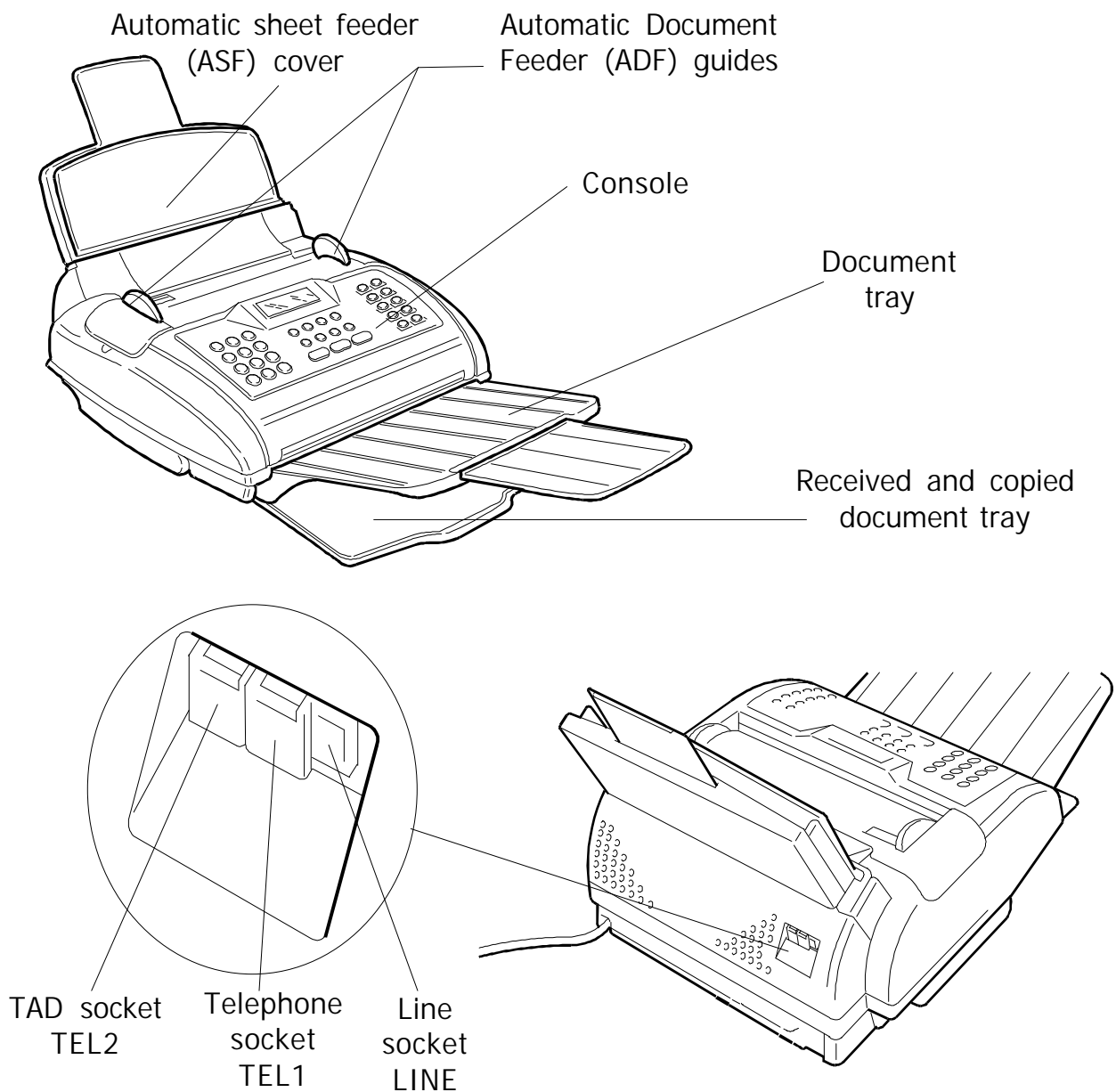
1. Insert the document into the automatic document feeder.
2. Type on the numeric keypad the number of copies to start (max. 50 copies)
3. Press the **START** key.



## 2. GENERAL DESCRIPTION

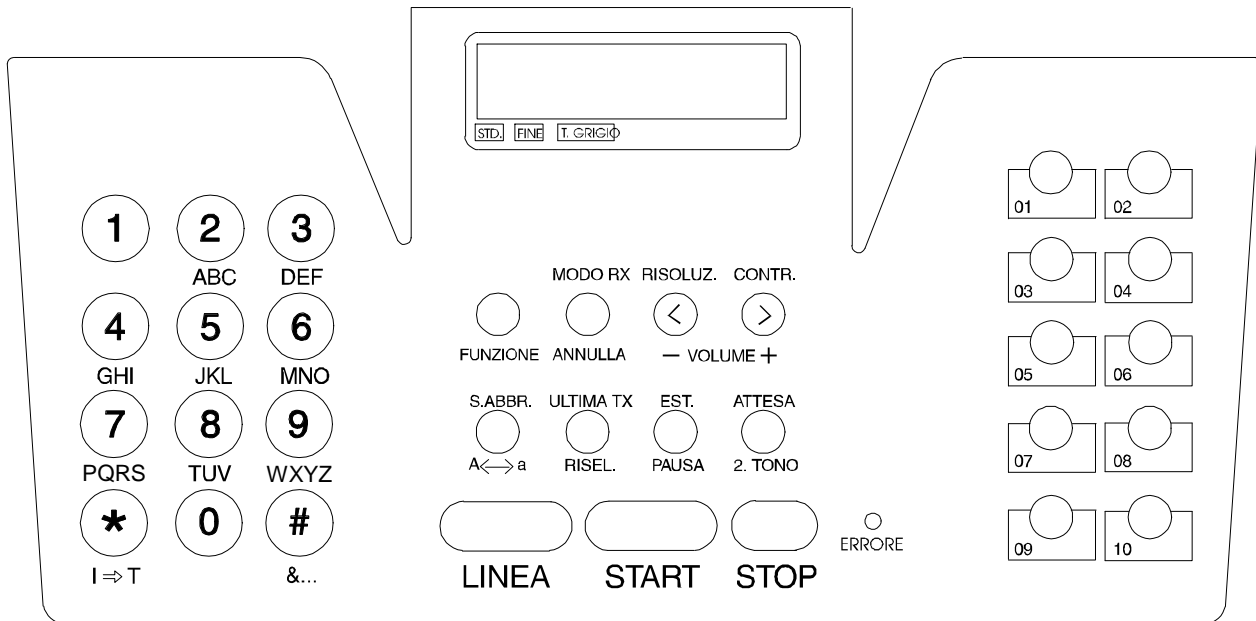
### 2.1 EXTERNAL PARTS

The figure shows the main external parts, of the facsimile machine.



**Fig. 2-1 External parts of the facsimile machine**

## 2.1.1 Console



**Fig. 2-2 Console layout**

The console comprises:

- a **display** consisting of **2 lines of 16 characters** each
- a **keypad** consisting of:
  - 11 function keys (**HOOK - START - STOP - S. DIAL - LAST TX - EXT. - HOLD - FUNCTION - RX MODE - RESOL. - CONTR.**) of which 7 are dual function keys (**CLEAR - VOLUME+ - VOLUME- - A ↔ a - REDIAL - PAUSE - 2.TONE**)
  - 12 dual-function keys: for **normal dialling** (**0 - 1 - 2 - 3 - 4 - 5 - 6 - 7 - 8 - 9 - \* - #**) or **user name setting** (**ABC - DEF - GHI - JKL - MNO - PQRS - TUV - WXYZ - P → T - &...**)
  - 10 keys for **one-touch dialling**
  - 1 LED for indicating an **ERROR**.

## 2.1.2 Functions of the console keys

Some keys perform different functions according to the current operating mode of the facsimile machine:

- ① **Stand-by** mode *with document* on the ADF
- Stand-by** mode *without document* on the ADF
- Function** mode (activated by pressing the FUNCTION key), irrespective of the presence of a document on the ADF
- Hook** mode (activated by pressing the HOOK key).

Key	Mode	Functions
Number keys	①	Used for <b>dialling numbers</b> . Select <b>alphanumeric characters</b> for inclusion in the mnemonic ID.
	★	① In pulse dialling mode, <b>changes the dialling mode</b> to tone. In tone dialling mode, <b>emits a tone</b> on line for special network services. Scrolls <b>forwards</b> through the <b>special characters and symbols</b> available for the mnemonic ID or selects the + character for the user's telephone number.
#	①	In tone dialling mode, <b>emits a tone</b> on line for special network services. Scrolls <b>backwards</b> through the <b>special characters and symbols</b> available for the mnemonic ID.
FUNCTION	①	Provides <b>access to</b> operator selection <b>menus and submenus</b> .
RX MODE	①	<b>Changes the reception mode</b> : automatic, manual, FAX/TEL, FAX/TAD.
CLEAR	①	<b>Clears</b> incorrect settings.
RESOL. <	①	Selects the <b>type of resolution</b> . <b>Moves the cursor left</b> during entry of the user's name and number.
- VOLUME		<b>Reduces the volume</b> of the speaker.

>>

Key	Mode	Functions
CONTR. >	①	Selects the <b>type of contrast</b> . <b>Moves the cursor right</b> during entry of the user's name and number.
VOLUME +		<b>Increases the volume</b> of the speaker.
S. DIAL A« a	①	<b>Enables</b> the setting of a <b>two-digit code</b> for speed dialling. <b>Changes from capitals to small letters</b> (or vice versa) during entry of the mnemonic ID.
LAST TX REDIAL	① ①	Pressed once, <b>displays the result of the last transmission</b> . Pressed twice, <b>redials the last number</b> .
EXT.	①	When the facsimile machine is connected to a private branch exchange, <b>enables access to the public line</b> .
PAUSE	①	<b>Inserts a pause</b> in automatic dialling and in speed and one-touch dial settings.
HOLD 2. TONE	① ①	Puts a telephone call <b>on hold</b> . <b>Sets the second tone</b> in automatic dialling and in speed and one-touch dial settings.
HOOK	①	Enables the user to <b>dial the number without lifting the receiver</b> and to <b>monitor the tones</b> through the speaker.
Keys 01-10	①	Start <b>one-touch dialling the fax number</b> associated with the key. <b>Enable the telephone number</b> associated with the key to be dialled when the START key is pressed. Used for <b>programming a one-touch dialling number</b> .
STOP	①	<b>Switches off</b> the <b>ERROR</b> LED. <b>Stops copying, sending or receiving</b> a document. Sets the facsimile machine in <b>standby</b> mode.

>>

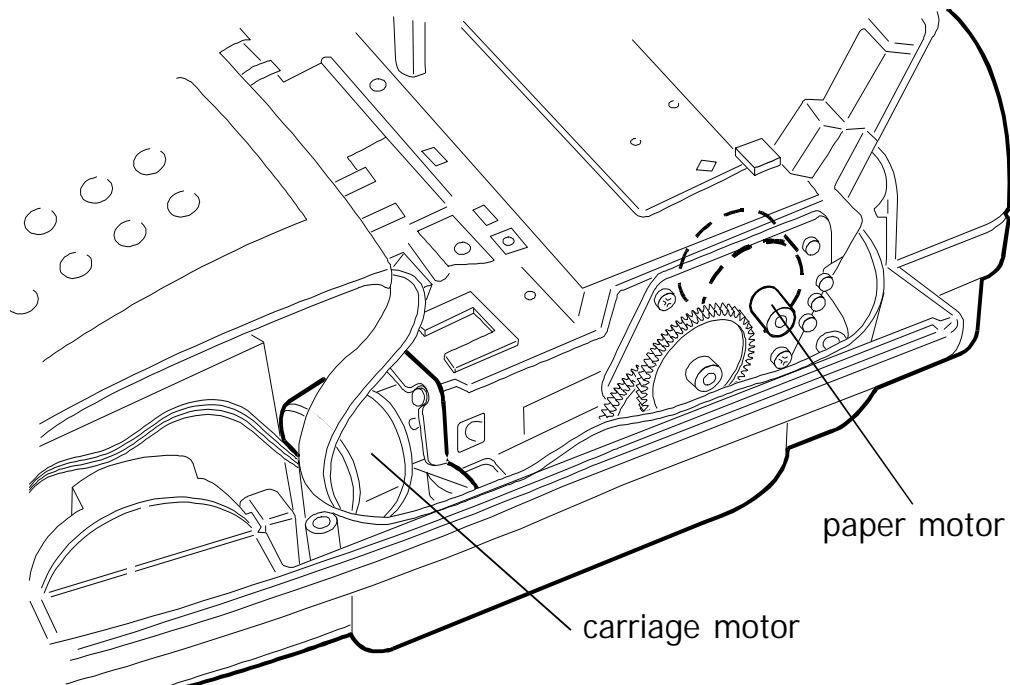


Key	Mode	Functions
START	①	<p><b>Starts copying</b> the document on the ADF.            After the number has been dialled, <b>starts sending</b> the document on the ADF.</p> <p>After a one-touch dial key has been pressed, starts <b>dialling the programmed telephone number</b>.</p> <p>After the receiver has been lifted, sets the facsimile machine in <b>manual reception</b> mode.</p> <p><b>Confirms</b> menus, submenus, parameters and values.            Sets the facsimile in <b>manual reception</b> mode.</p>

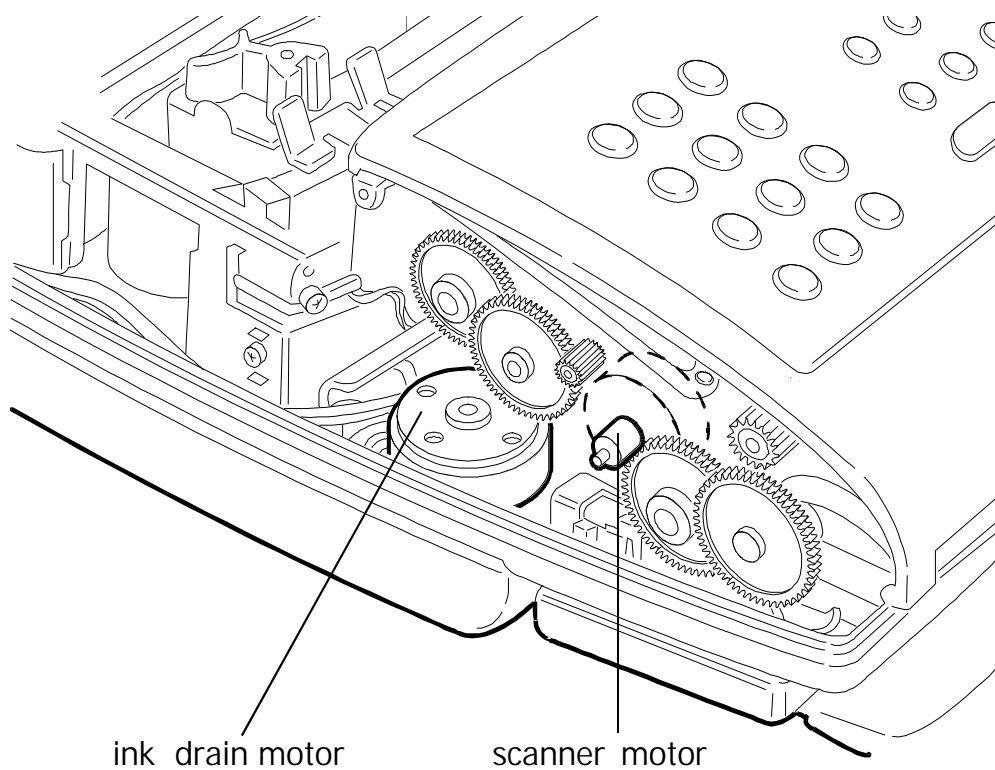
## 2.2 ELECTROMECHANICAL PARTS

### 2.2.1 Motors

Rear right-hand side

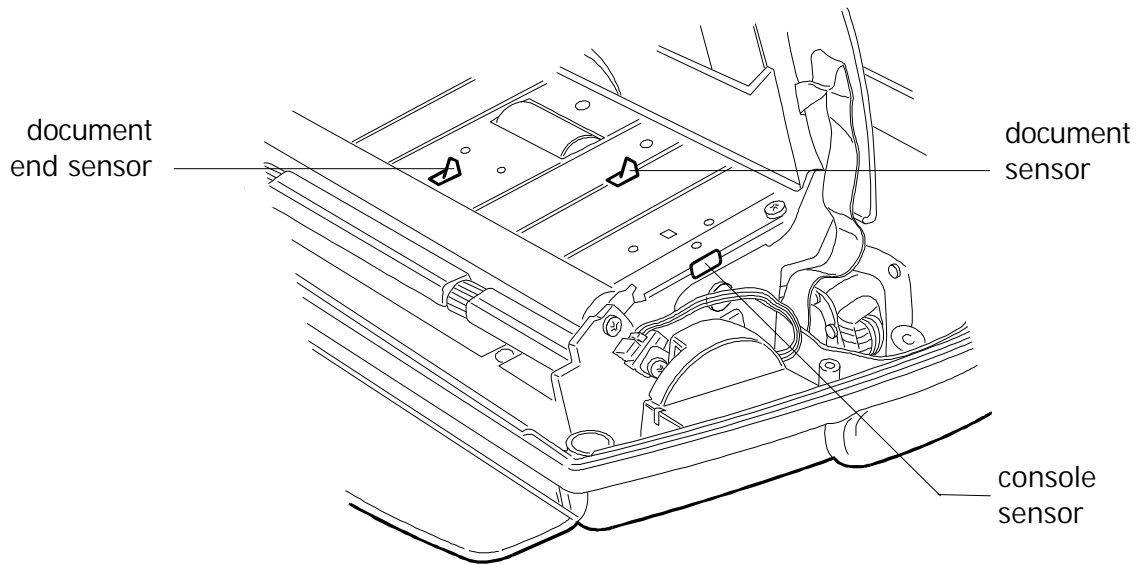


Rear left-hand side

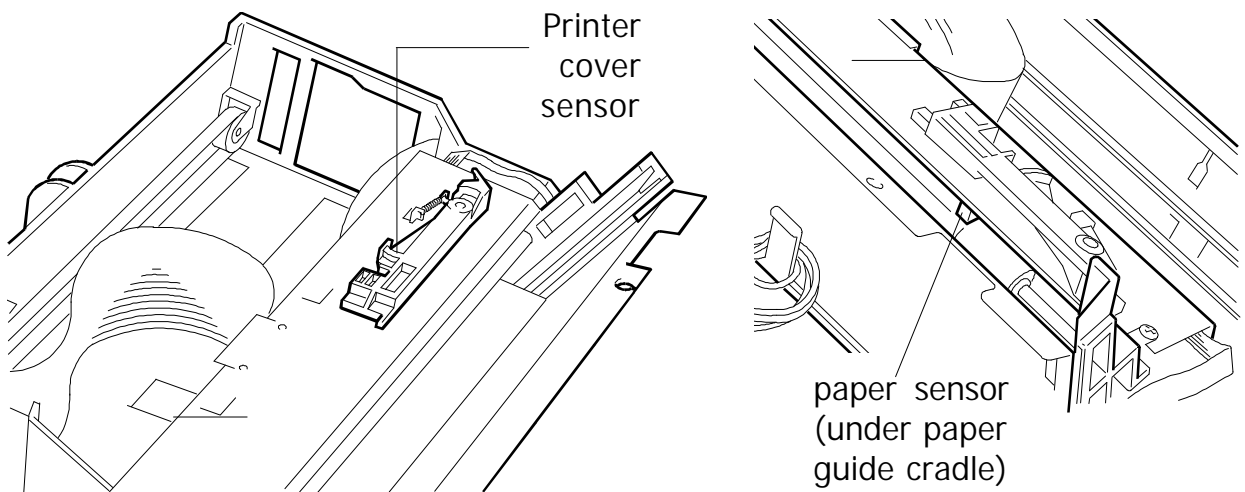


**Fig. 2-3 Locating the motors**

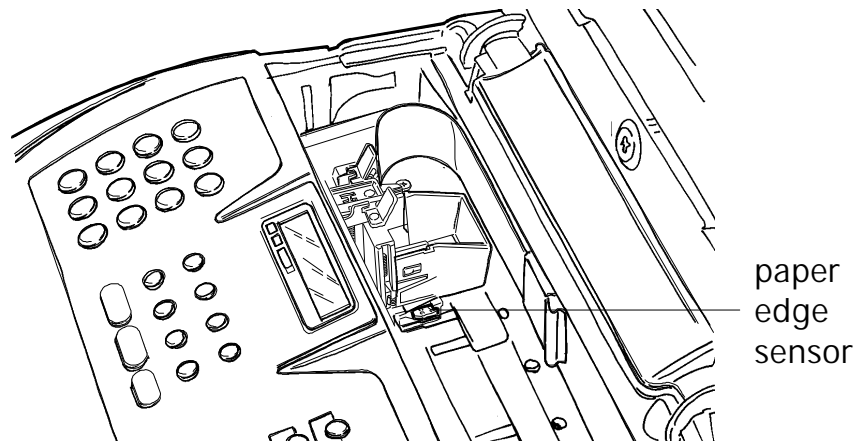
## 2.2.2 Sensors



**Fig. 2-4 Locating the console sensors**

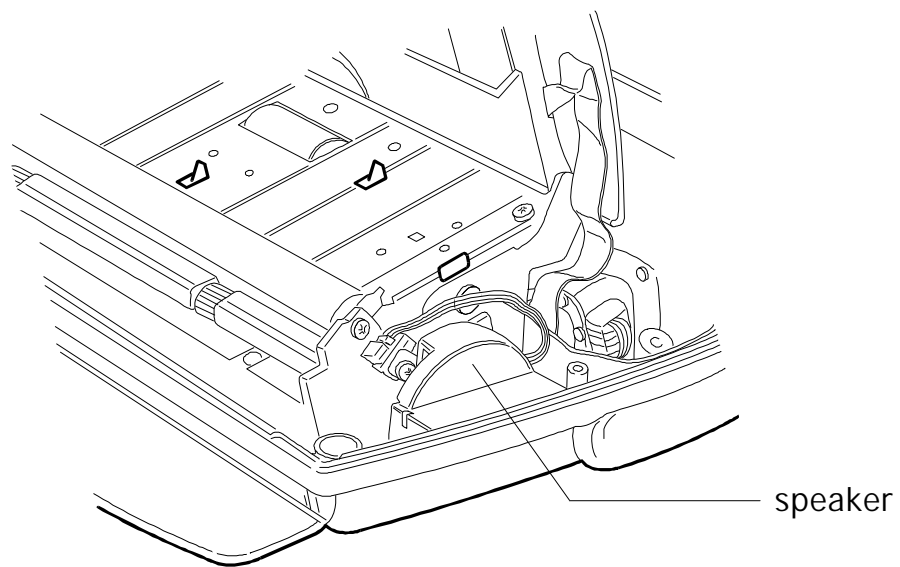


**Fig. 2-5 Locating the paper and printer sensors**



**Fig. 2-6 Locating the carriage sensor**

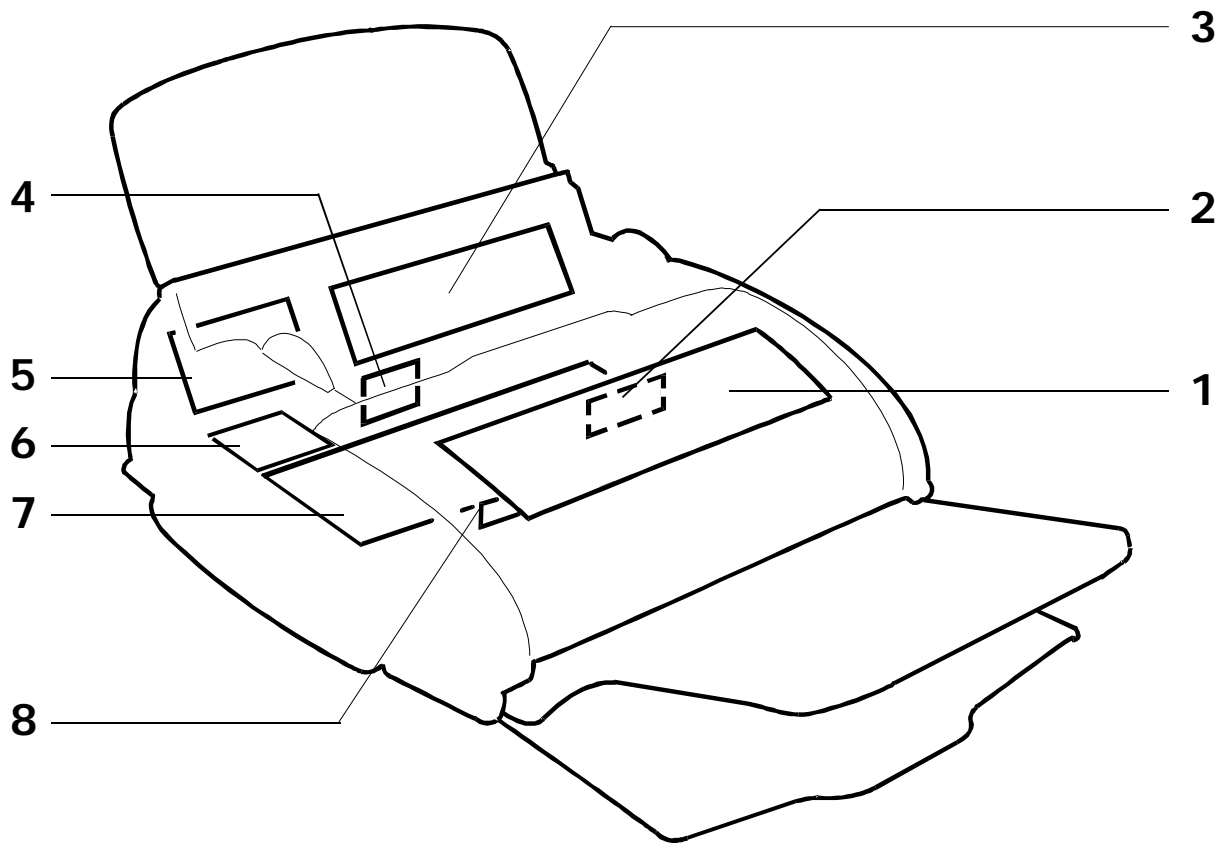
### 2.2.3 Speaker



**Fig. 2-7 Locating the speaker**

## 2.3 ELECTRONIC PARTS

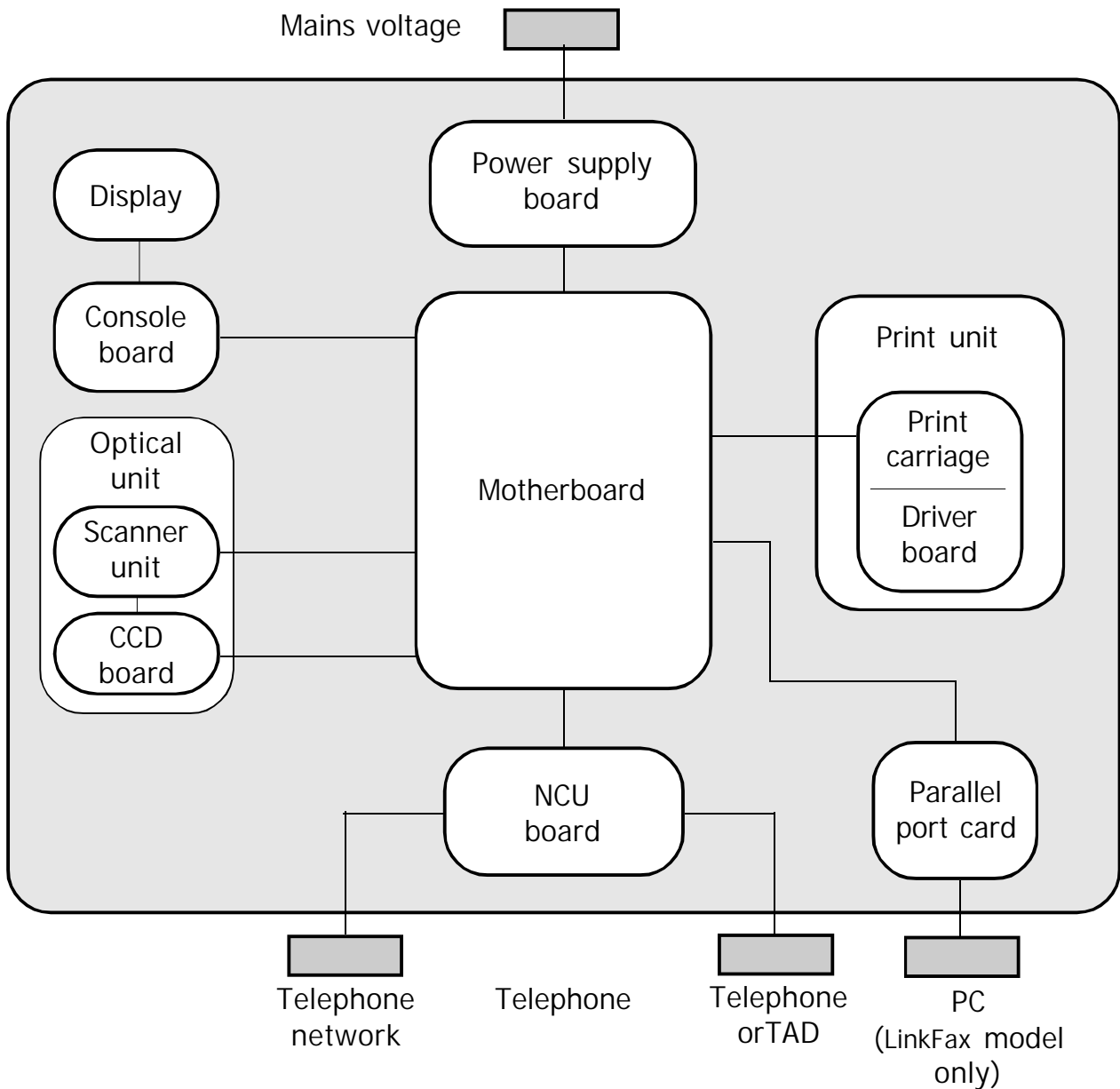
Figure 2-8 shows the boards assembled on the facsimile machine.



**Fig. 2-8 Locating the boards**

1. Console board
2. CCD board
3. Power supply board
4. Print head driver board (in the print carriage)
5. Network control unit (NCU) board
6. Parallel port card (LinkFax model, only)
7. Motherboard
8. LED array for illuminating the documents.

## 2.3.1 General Block Diagram



**Fig. 2-9 General block diagram**

The facsimile machine comprises the following main units:

- Motherboard
- Network control unit (NCU) board
- Console board, with the display
- Power supply board
- Parallel port card, for connection to the PC (LinkFax model, only)
- Optical unit, consisting of the scanner unit and CCD board
- Printer unit, consisting of the print head driver board (in the carriage) and the carriage drive mechanism.

### 2.3.2 Block Diagram of the Motherboard

The motherboard controls the entire machine by means of a central processing unit (CPU) which uses special circuits to handle four main functional units: the image processor (for processing the scanned document), the motors (for activating all the mechanical parts), the print head (for printing both received and copied documents) and the modem (for controlling the signals to and from the telephone network).

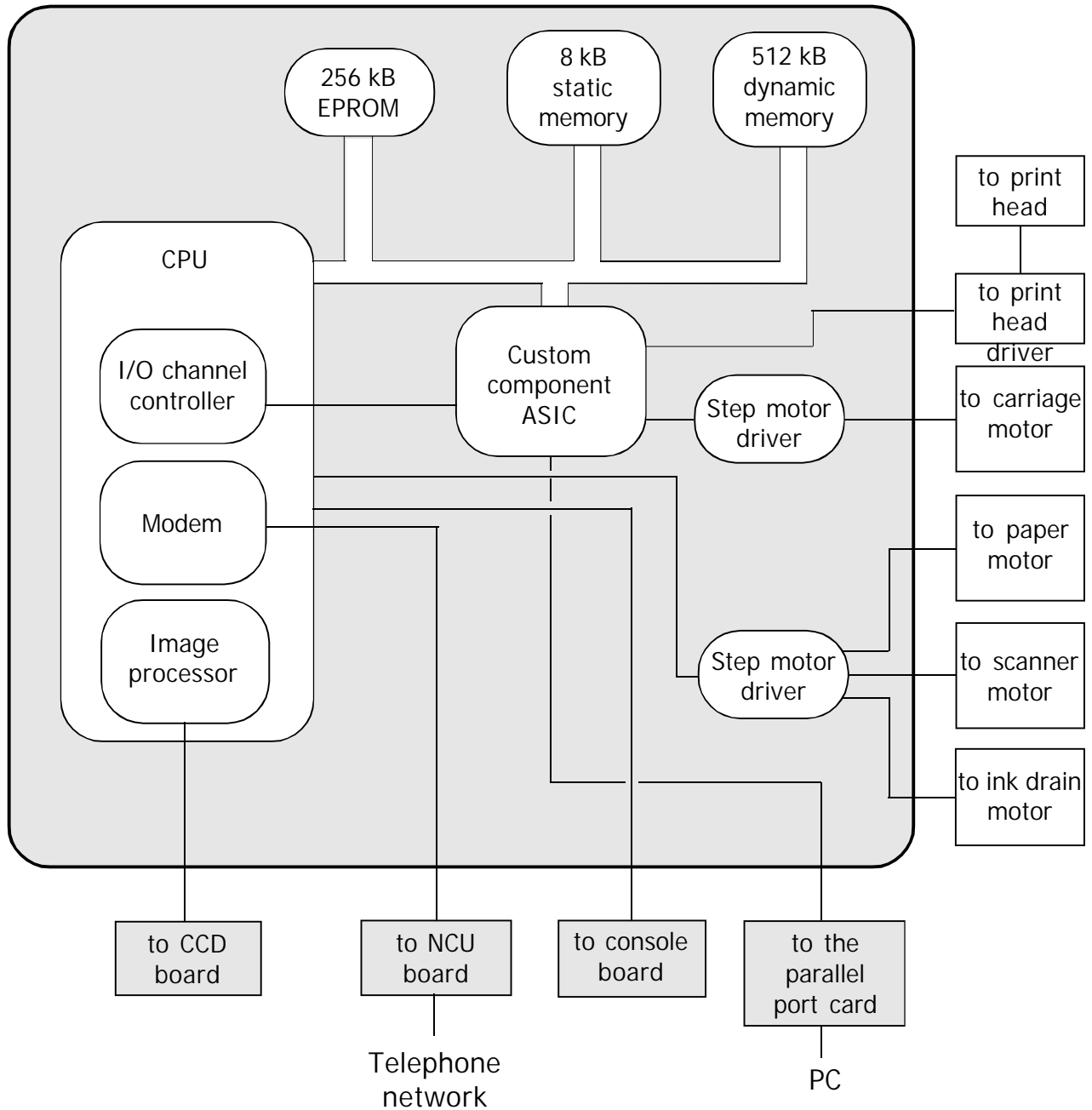
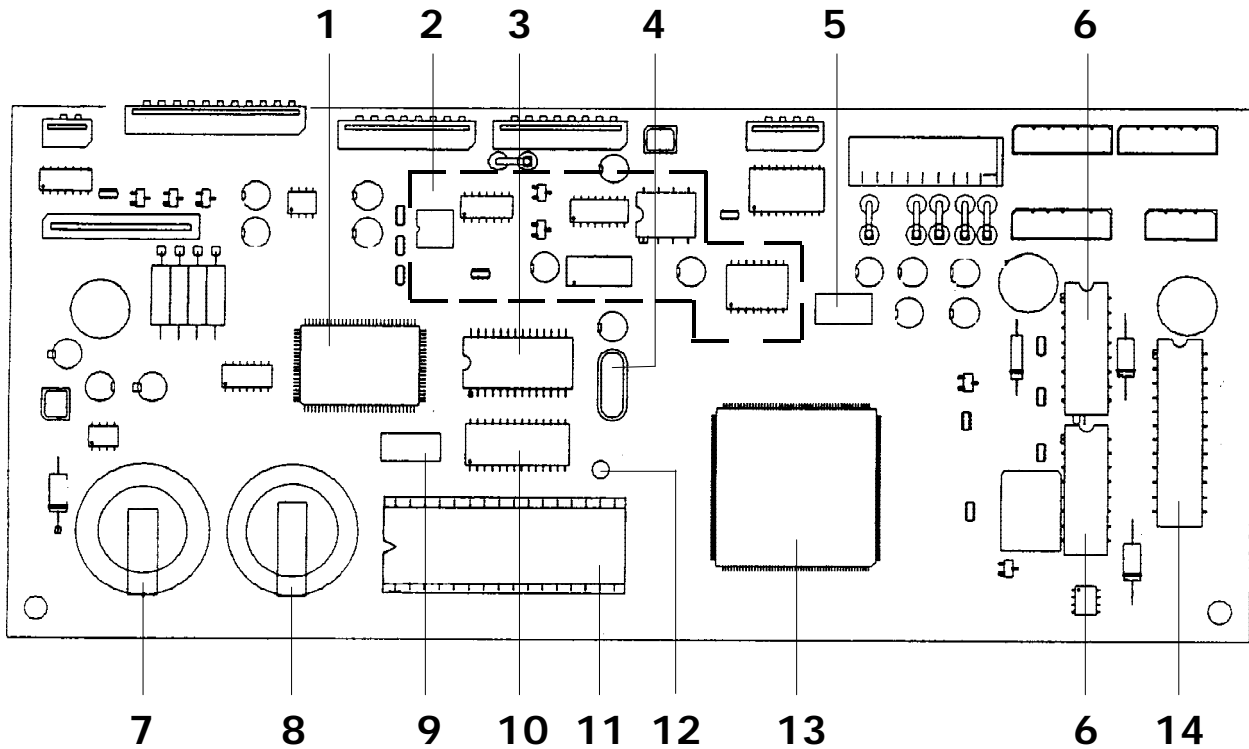


Fig. 2-10 Block diagram of the motherboard



**Fig. 2-11 Locating the motherboard components**

- |   |   |    |  |
|---|---|----|--|
| 1 | CUSTOM COMPONENT ASIC   | 8  | SYSTEM BATTERY (Lithium, 3 volts, 5-year duration) |
| 2 | MODEM CIRCUITS  | 9  | QUARTZ CRYSTAL FOR ASIC (16 MHz)                   |
| 3 | STATIC RAM (8 x 8 kbytes)   | 10 | DYNAMIC RAM (512 kbytes)                           |
| 4 | QUARTZ CRYSTAL FOR MODEM CLOCK (20.736 MHz)                                     | 11 | SYSTEM FIRMWARE EPROM (256 kbytes)                 |
| 5 | QUARTZ CRYSTAL FOR SYSTEM CLOCK (16 MHz)  | 12 | QUARTZ CRYSTAL FOR RTC (32.768 kHz)                |
| 6 | PAPER, SCANNER AND INK DRAIN MOTOR DRIVERS                                      | 13 | CPU (WITH BUILT-IN MODEM AND IMAGE PROCESSOR)      |
| 7 | BACK-UP RECHARGEABLE BATTERY FOR DYNAMIC RAM (Ni-Cd, 3 volts, 72-hour duration) | 14 | CARRIAGE MOTOR DRIVER                              |



The memory block, divided into the following three sections, is an integral part of the motherboard:



- **EPROM** (256 Kbytes), this memory contains the system *firmware*, the default settings of the software parameters and the *messages* in the various languages
- **STATIC RAM** (8 kbytes), this memory contains:
  - the *current user and service software parameters*
  - the *calibration settings* (alignment settings, CCD settings)
  - the *telephone number list* (one-touch dialling numbers, speed code dialling numbers, broadcasting lists)
  - the *power failure repor.*
- **DYNAMIC RAM** (512 kbytes), this memory contains:
  - the *compression and decompression buffer*
  - the *scanning buffer*
  - the *print buffer*
  - the *transaction memory* (activity reports)
  - the *user memory* (documents to send, documents received in the memory).

The data is retained in the dynamic memory even during a power failure by a **backup battery** capable of powering the system for 72 hours. The facsimile machine **must be left powered for 24 hours** to **recharge** this battery.

The data is retained in the static memory by the **5-year duration system battery**.

### 2.3.3 Block Diagram of the Network Control Unit Board

The NCU (Network Control Unit) board acts as the physical interface with the telephone line. The NCU board is available in several versions, to suit the specific needs of each country.

The figure shows the block diagram of a generic NCU board.

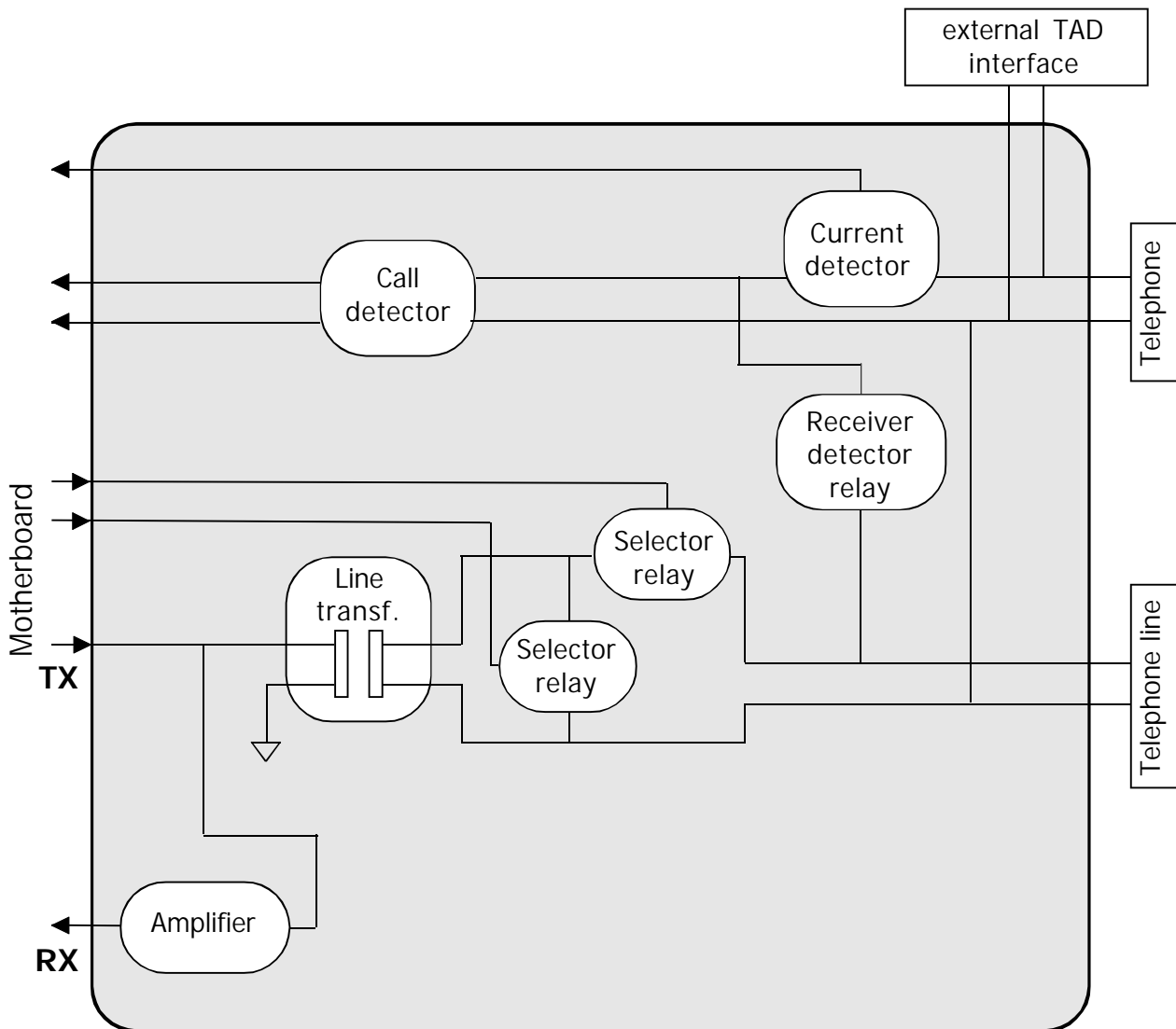
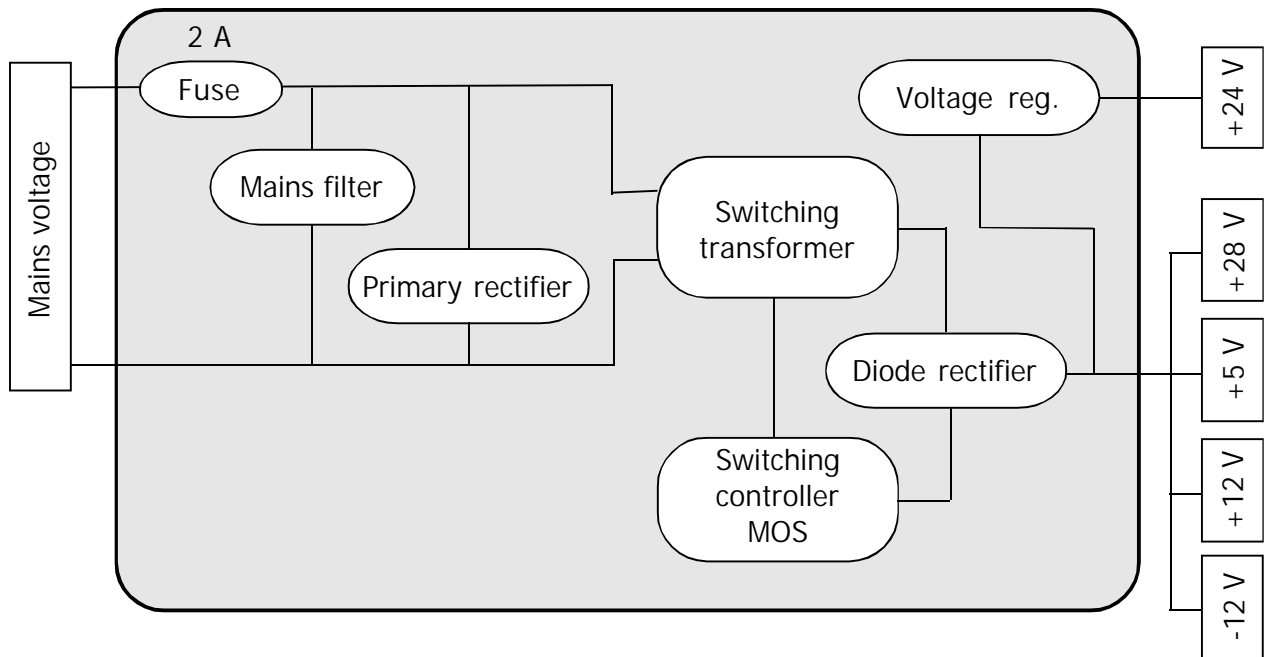


Fig. 2-12 Block diagram of a generic NCU board

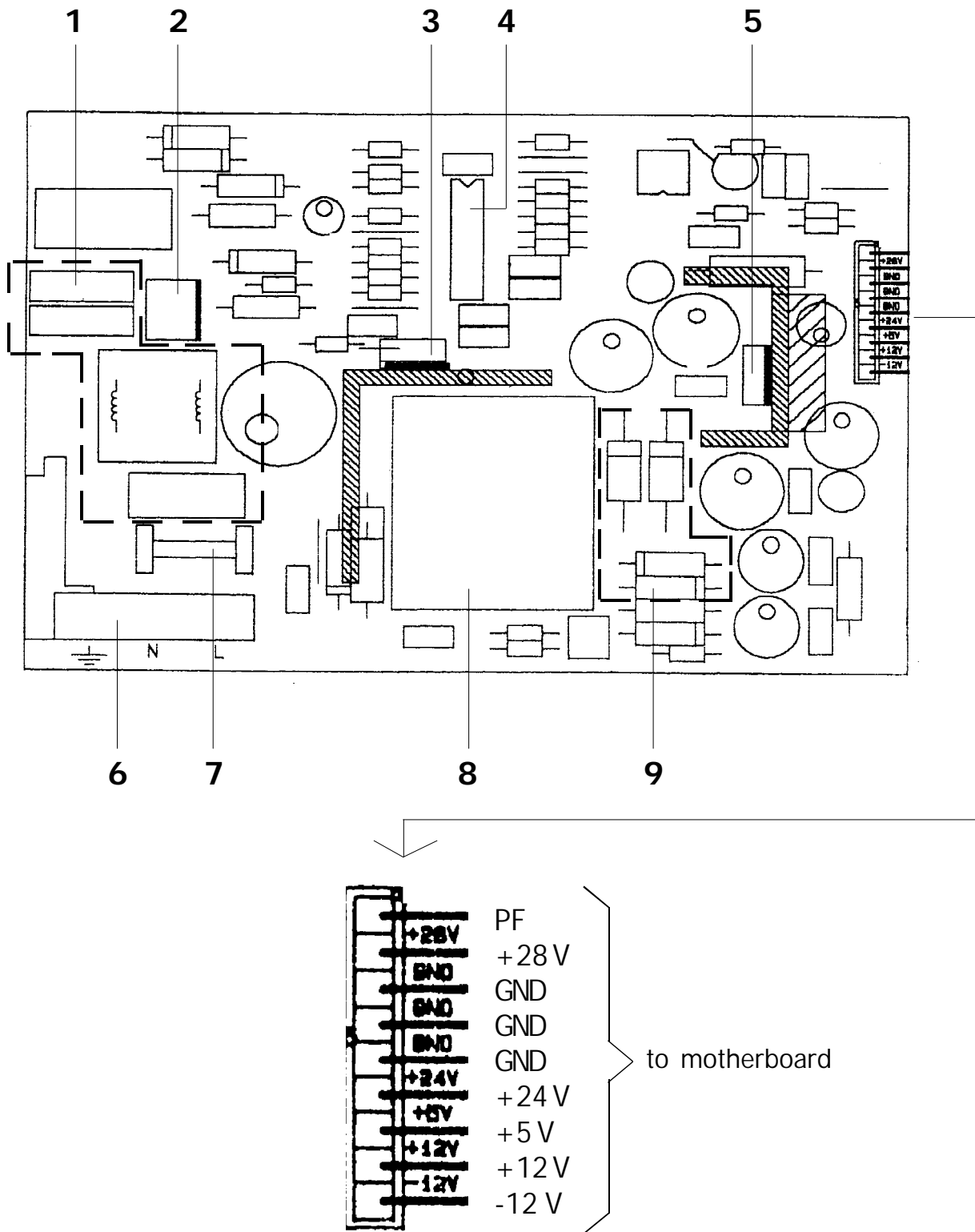
### 2.3.4 Block Diagram of the Power Supply Board



**Fig. 2-13 Block diagram of the power supply board**

The power supply board provides a maximum power of 35 Watts and supplies, via the switching circuit, the following direct voltages:

- +28 VDC ( $\pm 10\%$ ), for the motors, variable according to the load
- +24 VDC ( $\pm 2\%$ ), for the print head
- +12 VDC ( $\pm 10\%$ ), for CCD, NCU and logic circuits
- -12 VDC (+10% -15%), for CCD and logic circuits
- +5 VDC ( $\pm 5\%$ ) for sensors and logic circuits.



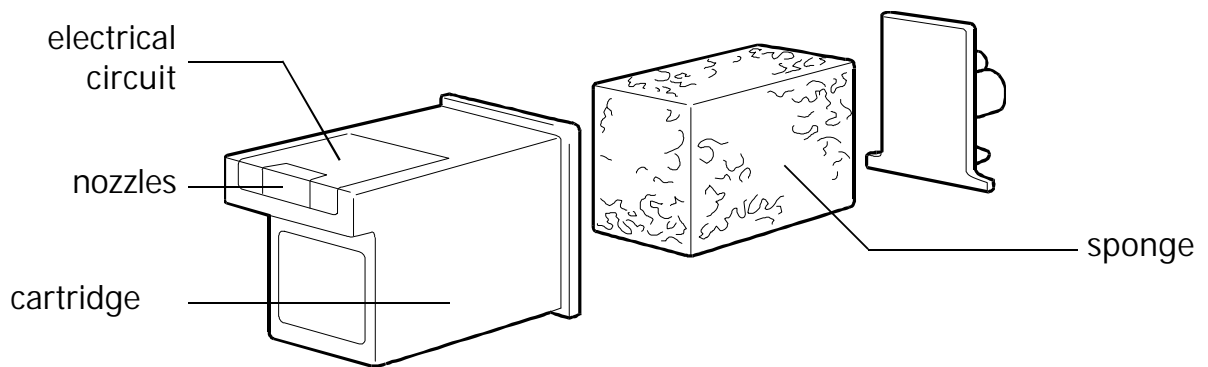
**Fig. 2-12a Locating the power supply components**

1	Mains filter	4	Stabilizer	7	Fuse (2 A)
2	Primary rectifier	5	+24 VDC regulator	8	Transformer
3	Switching controller MOS	6	Mains connector	9	Diode rectifier

### 2.3.5 Printer Unit

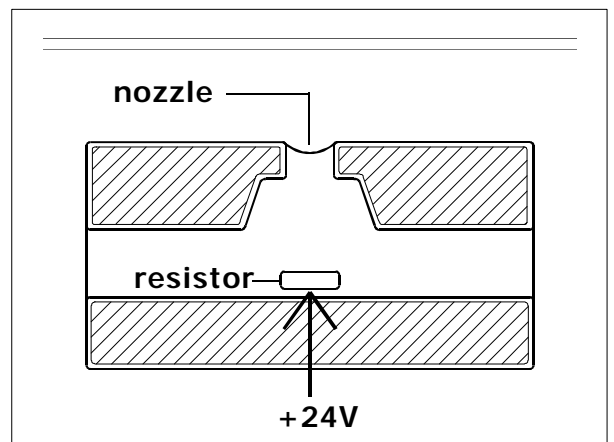
The facsimile machine has a bubble ink jet system which uses a special head and prints on plain paper.

The bubble ink jet print head consists of an interchangeable cartridge, which contains a sponge soaked with liquid ink, which is ejected from 50 nozzles made of a nickel and gold component, under the control of the signals that reach an electrical circuit consisting of 50 resistors (Fig. 2-13).

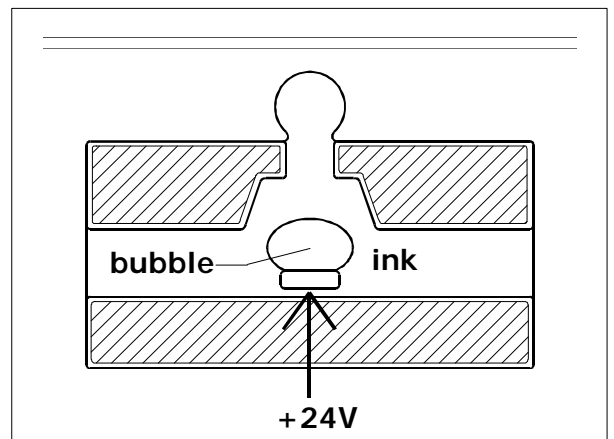


**Fig. 2-13 Composition of the print head**

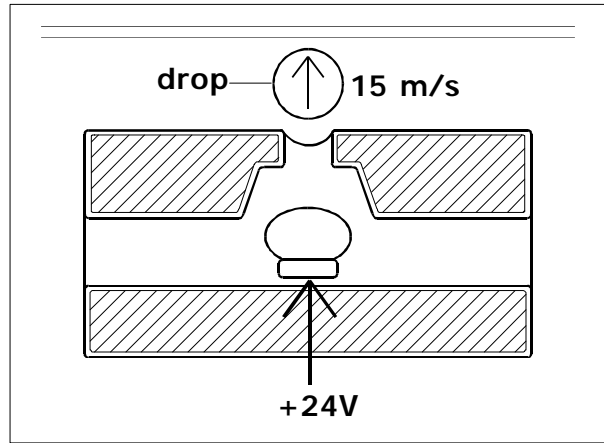
Each nozzle generates a drop of ink when the corresponding resistor is powered (+24 Volt) for a few microseconds.



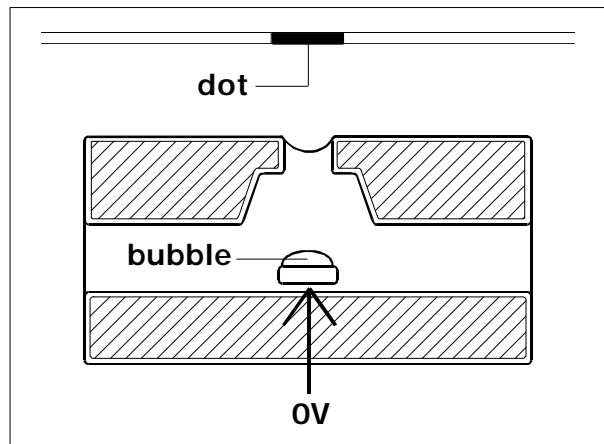
The resistor is heated and the ink that is in direct contact with it evaporates, expanding like a bubble and pressing the rest of the ink against the nozzle.



As a result, a drop of ink is ejected from the nozzle at a speed of 15 metres a second until it strikes the paper on which it makes a dot.



When the resistor is powered off, the bubble collapses quickly, drawing from the sponge a quantity of ink equal to the amount ejected. 800 microseconds after the ink has been ejected, the nozzle is ready to eject another drop.



# 3. INSTALLATION AND INITIALIZATION PROCEDURES

Installation of the facsimile machine consists of three separate phases:

1. **PRELIMINARY OPERATIONS**, or *fitting together the parts* supplied in the packaging and subsequent *connection* of the facsimile machine and telephone, if present, *to the telephone network*
2. **INSTALLATION**, or *setting the parameters indispensable* for the facsimile machine's operation.
3. **SETUP**, or *setting the customization parameters*.

## 3.1 PRELIMINARY OPERATIONS

### 3.1.1 Unpacking the Facsimile Machine

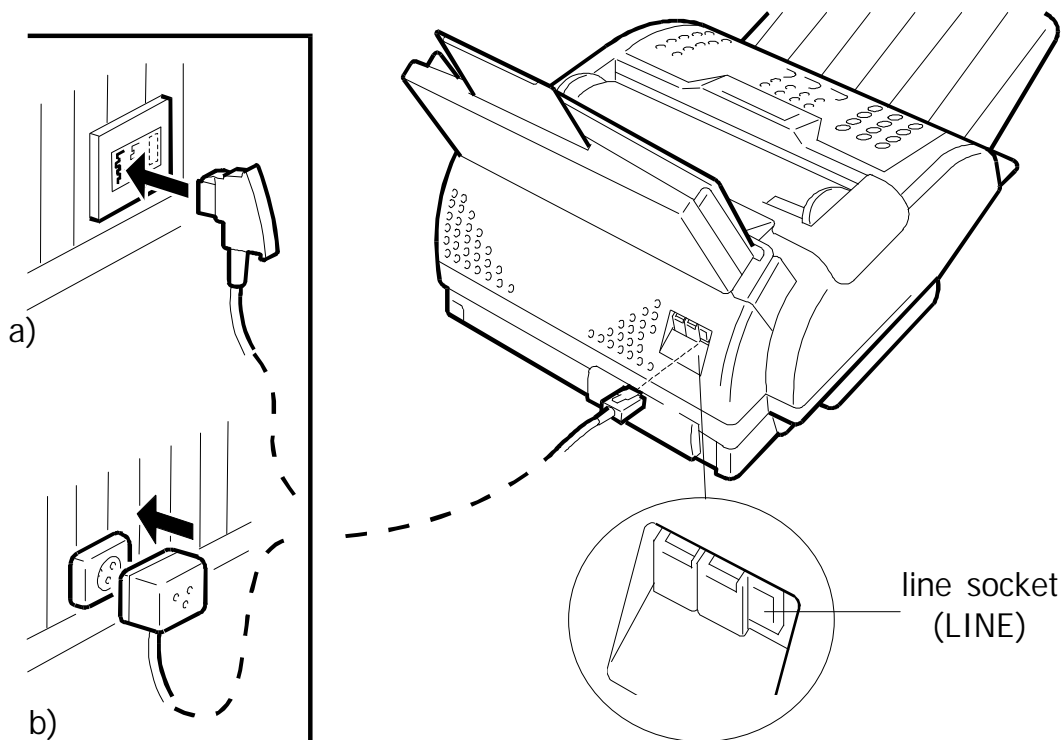
Having removed the facsimile machine and the other parts from the packaging, check that the following elements are present:

- the facsimile machine (complete with power cord)
- a packet containing the print head
- the telephone cable (with two international RJ11 connectors)
- an adapter for the telephone cable (only required in some countries)
- the document tray, with a pull-out extension
- the received or copied document tray
- the automatic sheet feeder (ASF), with a pull-out extension
- the User Guide, complete with the Quick Reference Guide.

### 3.1.2 Connecting to the Telephone Line

**WARNING:** check that the **power cable** is **plugged into the power outlet**, before connecting the facsimile machine to the telephone line.

To connect the **facsimile machine** to the telephone line, plug one end of the telephone cable to the line socket (LINE) on the facsimile machine and the other end into a wall socket (see Fig. 3-1, a) or using the adapter if necessary (see Fig. 3-1, b).



**Fig. 3-1 Connecting the facsimile machine to the telephone line**

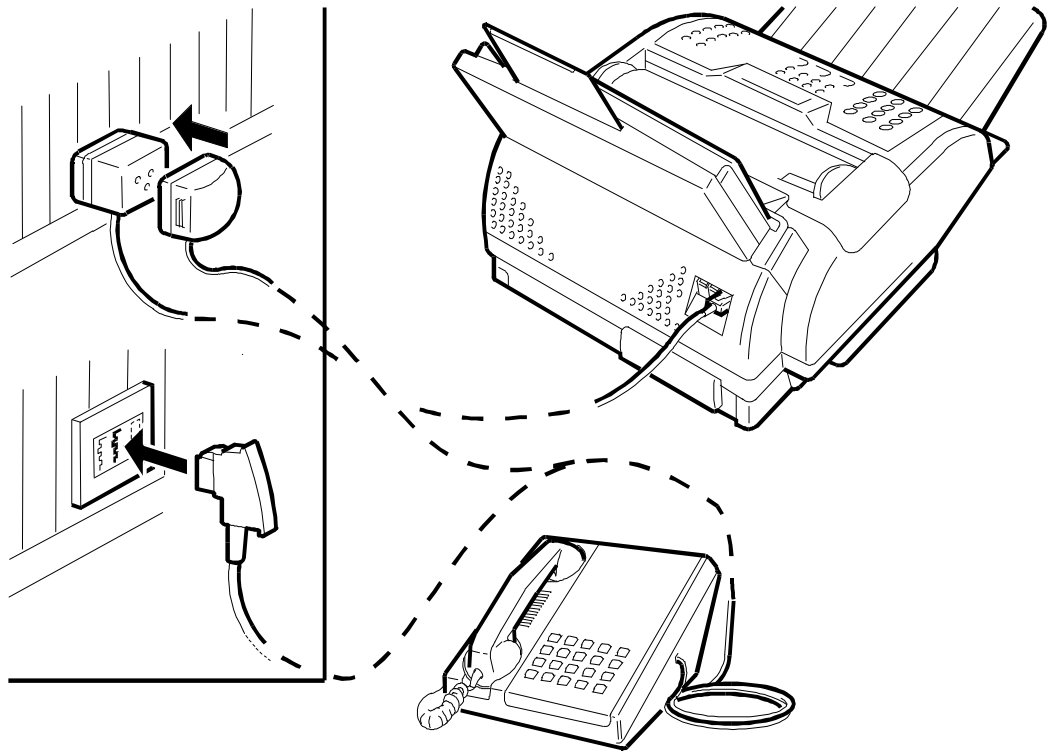
To connect a **telephone** to the telephone network, proceed in either of the following two ways:

- a) if the telephone has a national plug (case a), insert the plug into the adapter (see Fig. 3-2, a) or specific wall telephone socket (see Fig. 3-2, b)
- b) if the telephone has an international connector (case b), remove the precut tab that covers the telephone socket (TEL1) of the facsimile machine, then insert the connector directly into the telephone socket (see Fig. 3-3).

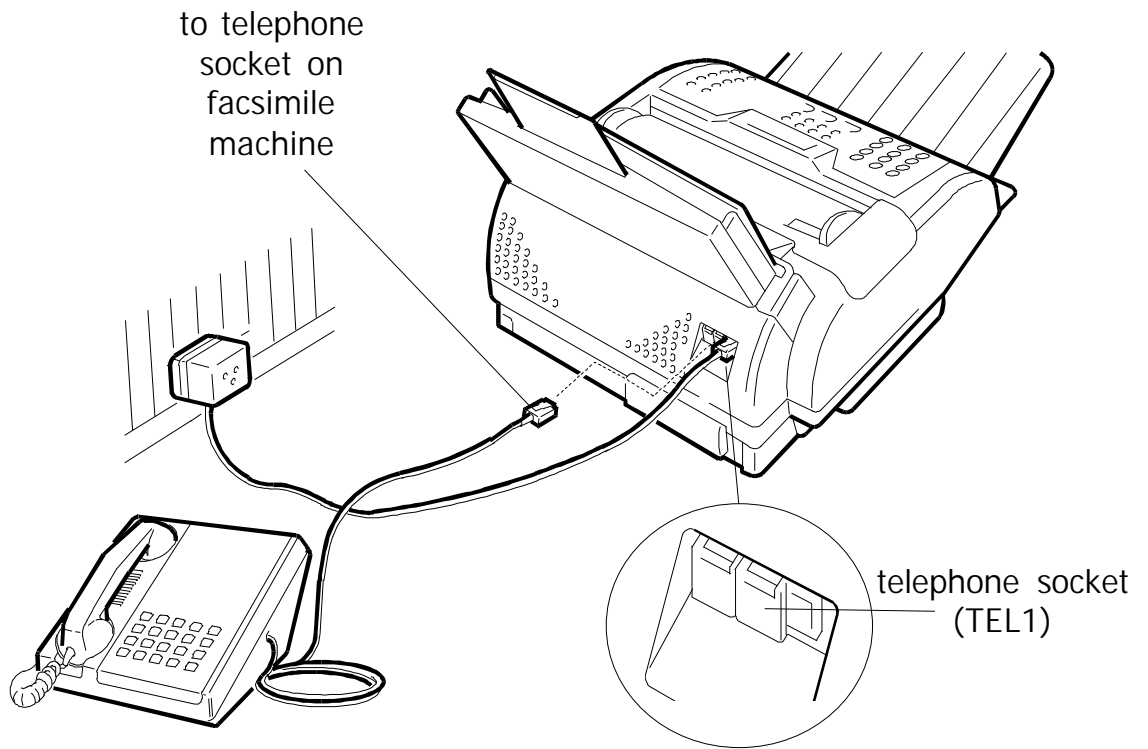
#### **Important**

As the telephone connection depends on regulations that vary from one country to another, figures 3-2 and 3-3 show an intentionally generic connection: for a detailed description of the procedure, see the regulations in force in your own country.





**Fig. 3-2 Connecting the telephone (case a)**



**Fig. 3-3 Connecting the telephone (case b)**

### 3.1.3 Connecting the Power Cord

Plug the power cord into the wall socket.

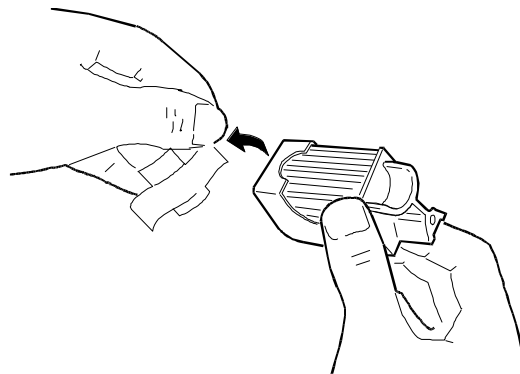
### 3.1.4 Installing the Print Head

- 1) Power on the facsimile machine and wait for the following message to appear:



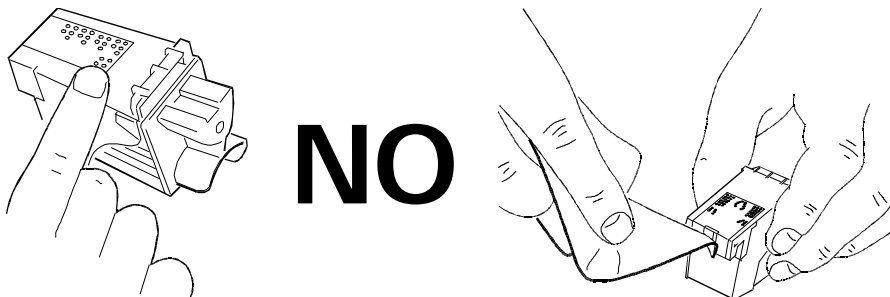
**WARNING:** if the message does not appear in your language, carry out the country setup procedure described in section 3.2.2 and continue with this procedure from step 2

- 2) Open the print head packet and remove the sealed box containing the print head.
- 3) Open the box and remove the print head, holding it by the grip, then remove the label covering the nozzles (see Fig. 3-4)

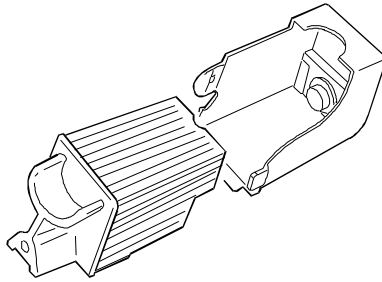


**Fig. 3-4 Removing the protective label**

**WARNING:** *do not touch the electrical contacts or the print head nozzles*

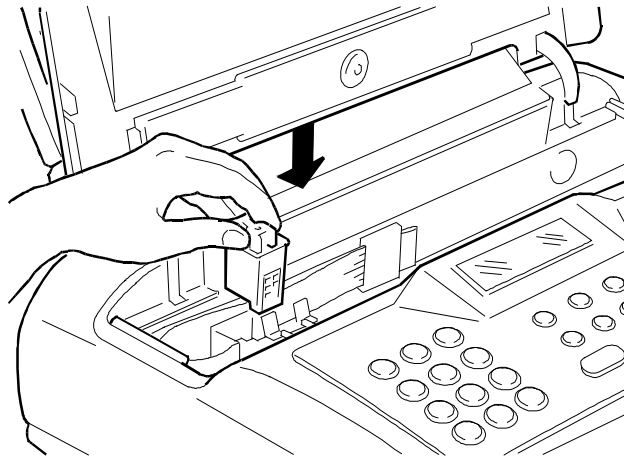


In addition, if the print head has an interchangeable cartridge, **do not separate the cartridge from the print head**



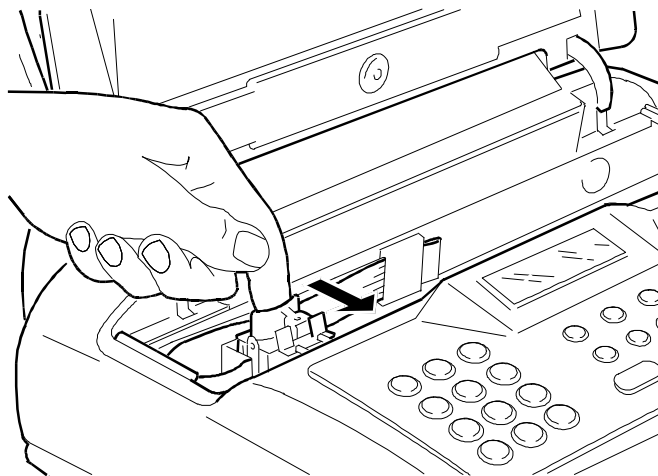
**NO**

- 4) Tilt the printer cover, then insert the print head in position with the **electrical contacts facing the front** of the machine (Fig. 3-5)



**Fig. 3-5 Inserting the print head**

- 5) Taking care not to obstruct the hole on the top, insert your index finger in the recess on the print head and pull it **until you hear it clearly click into position** (Fig. 3-6)



**Fig. 3-6 Fixing the print head in position**

6) Having inserted the print head, close the printer cover

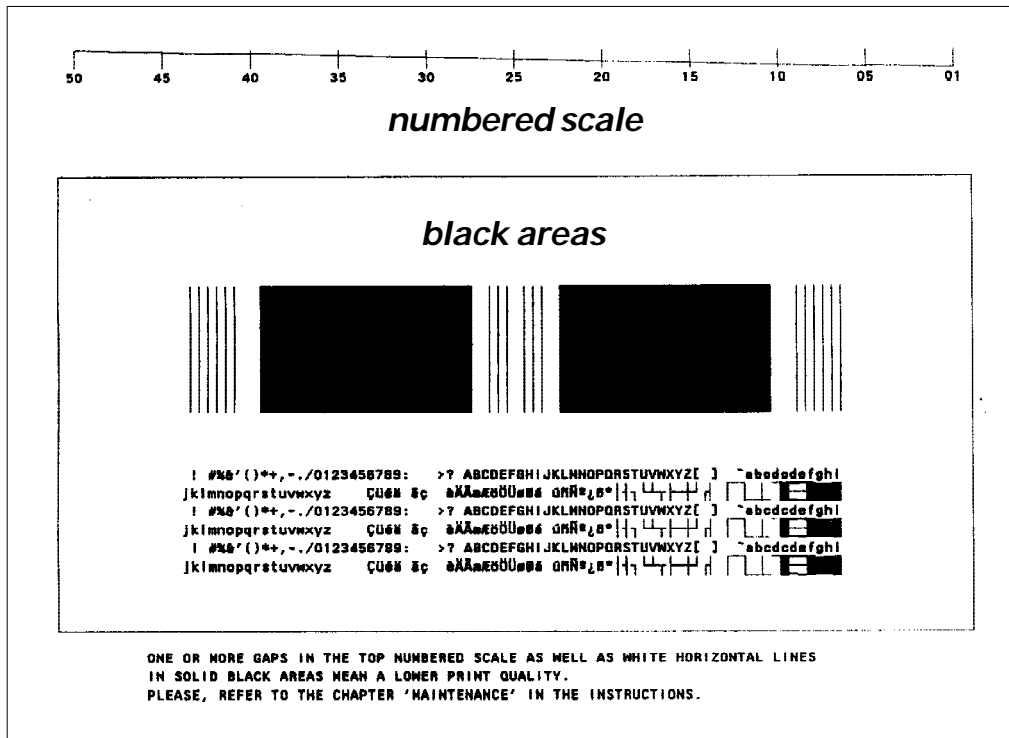
**WARNING:** if a *disposable print head* has been inserted, the following message generally appears:

NEW PRINT HEAD?  
1=YES      0=NO

Should this message not appear, press the **FUNCTION** key three times, then press the **START** key to make it appear. Now type **1** and press the **START** key.

7) The facsimile machine automatically loads a sheet of paper and starts the *nozzle cleaning and checking procedure*, which ends by:

- *printing out* the following *print chart* on the automatically loaded sheet (\*)



which contains:

- a *numbered scale*, for checking the flow of ink and the electrical circuits controlling the print head nozzles
- a section of *graphics and text*, for evaluating print quality

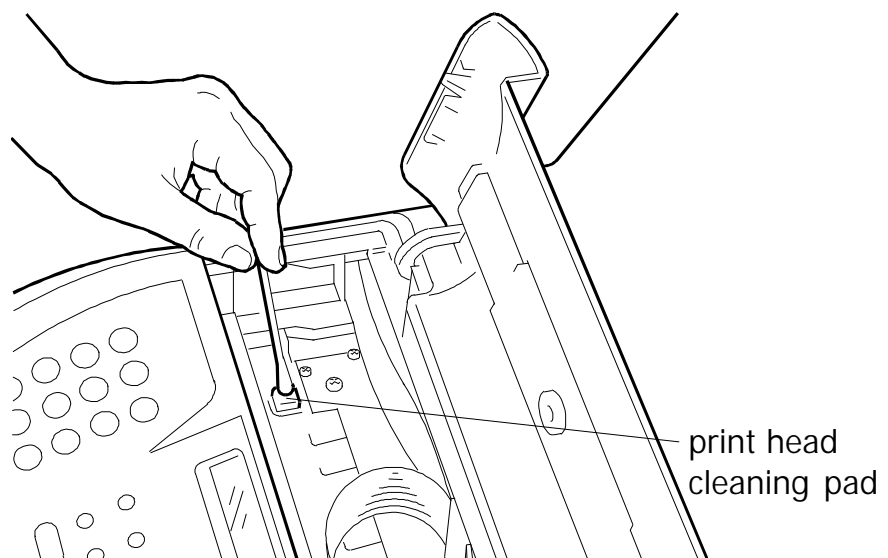
- the following **message** appears

CHECK PRINTOUT  
1=EXIT    0=REPEAT

(\*) only if bit 2 of SW09 is set to 1.

8) Analyse the print chart as follows:

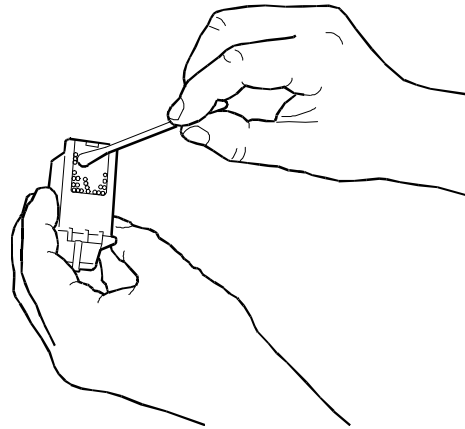
- Check that there are **no gaps** in the numbered scale and that there are **no horizontal white lines** in the black areas: under these conditions, which indicate that the print head has been inserted correctly and is in perfect working order, type **1**: the facsimile machine returns to stand-by and is ready for use
- If there are **gaps or white lines**, type **0** to repeat the nozzle cleaning procedure: if the new print chart is still unsatisfactory, repeat the procedure again
- If the printing quality is still not up to the required standard after the procedure has been performed three times, proceed as follows until a satisfactory print chart is obtained:
  - Make a copy of a document with the desired type of graphics and text and assess its quality.
  - Change the type of paper (the paper you are using may be too porous) and repeat the procedure.
  - Remove and reinsert the print head.
  - Remove the print head and check that there is no foreign body on the printing nib; if there is, remove it with care, taking care not to touch the electrical contacts; slide the print carriage to the right, then clean the print head cleaning pad using a cotton swab soaked in water, taking care not to leave any fluff (Fig. 3-7);



**Fig. 3-7 Cleaning the print head cleaning pad**

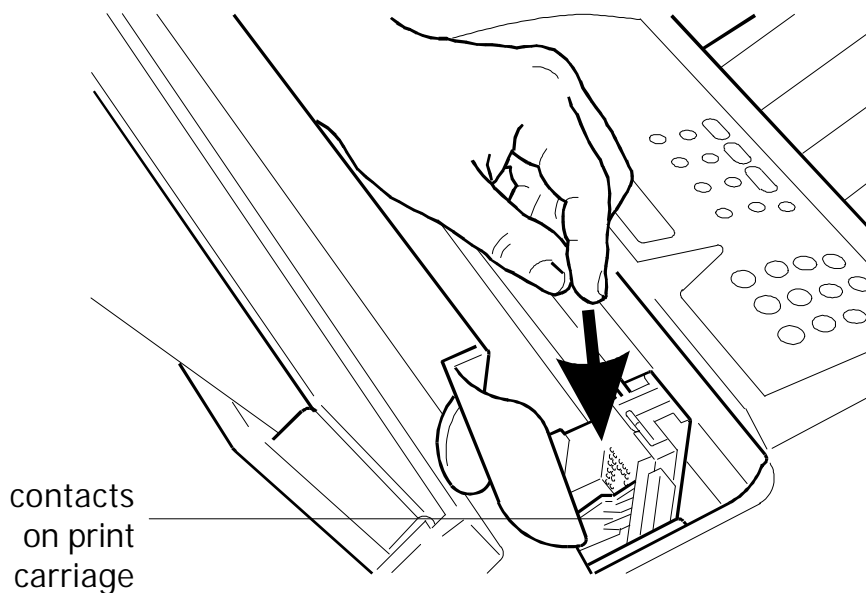
reinsert the print head.

- Remove the print head and clean the contacts with a piece of felt, pressing firmly (see Fig. 3-8);



**Fig. 3-8 Cleaning the print head contacts**

clean the contacts on the print carriage with a soft, dry cloth (see Fig. 3-9);



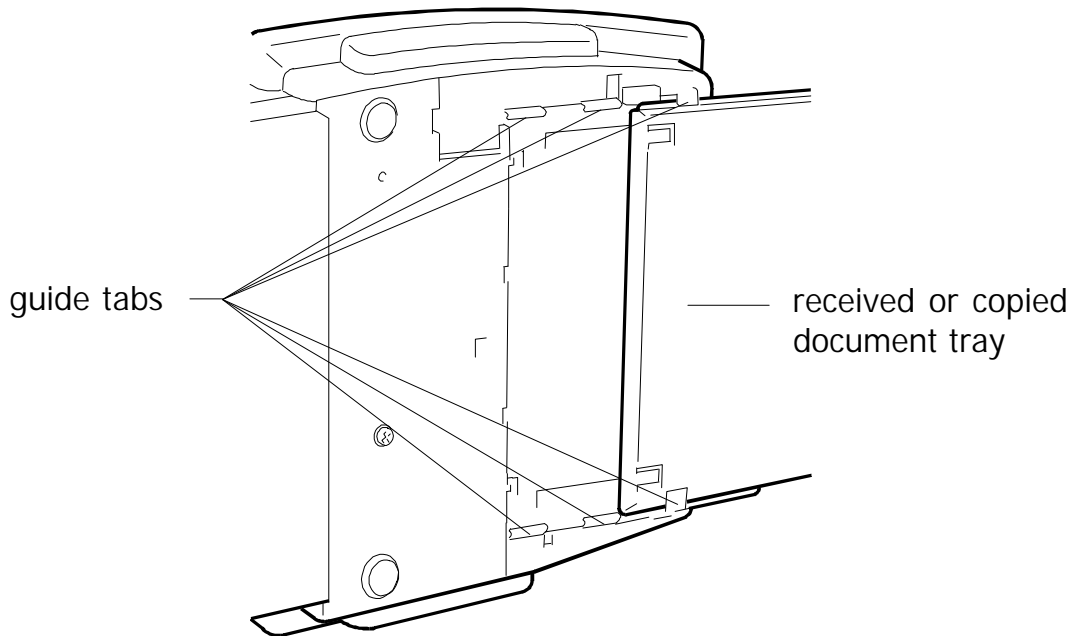
**Fig. 3-9 Cleaning the contacts on the print carriage**

reinsert the print head.

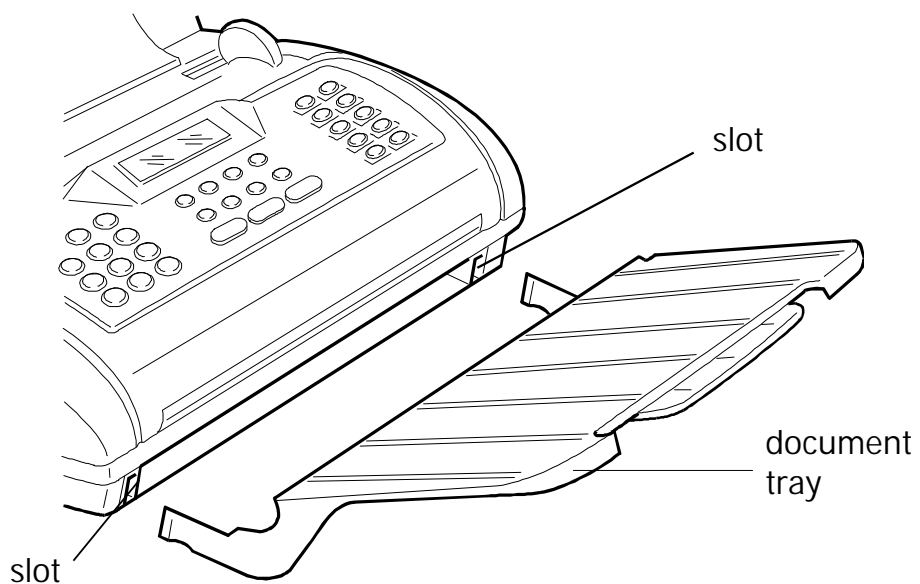
- Replace the print head
- Replace the print carriage (see section 7.2.15).

### 3.1.5 Inserting the Output Trays

Place the received or copied document tray on the guide tabs, and the document output tray between the two slots on the sides (see Figs. 3-10 and 3-11)



**Fig. 3-10** Inserting the received or copied document tray

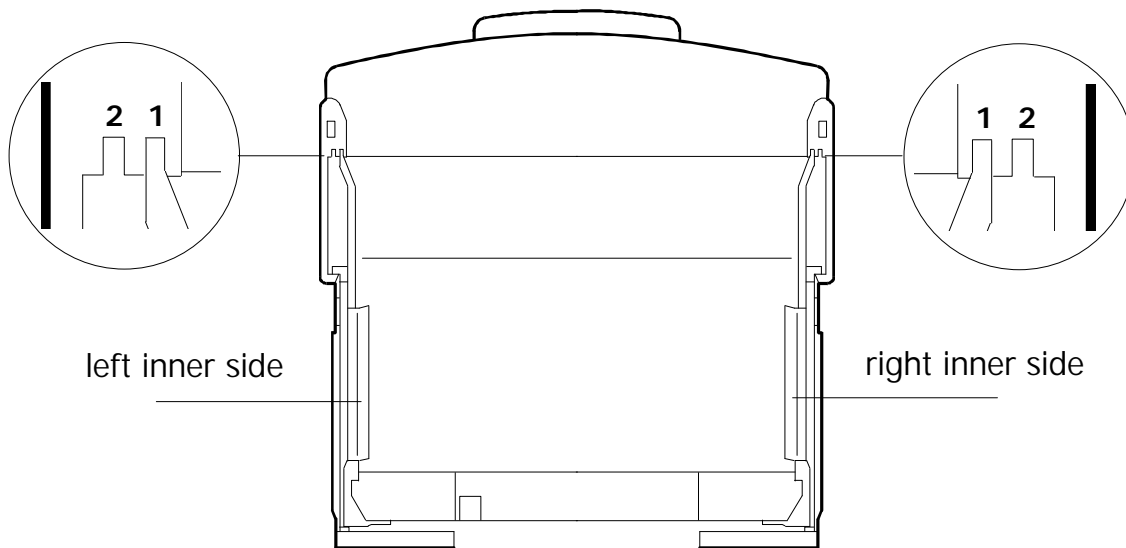


**Fig. 3-11** Inserting the document tray

### 3.1.6 Loading Paper

When adding paper to print received and copied documents, the following three factors must be taken into consideration and **must always match** for the facsimile machine to work properly:

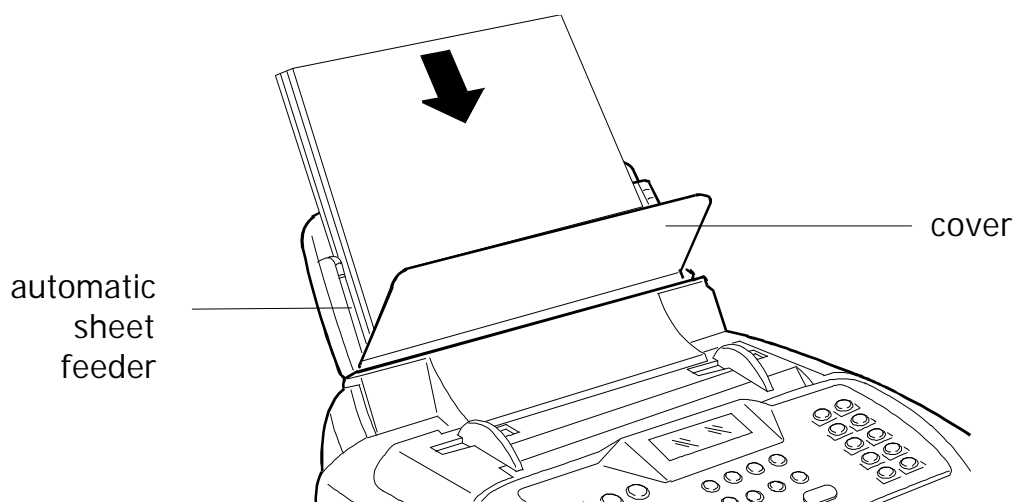
- **paper size**, i.e. the width of the paper used
  - **ASF tray width**, i.e. the distance between the inner sides of the ASF tray
  - **printing format**, i.e. the setting of the FORMAT parameter in the PRINTER PARAMETERS menu
- 1) Check that the ASF is set for the paper size you wish to use, i.e. that the **distance between the inner sides** coincides with the **width of the paper** used. If it does not, remove the cover of the ASF by gripping it at the centre of its lower edge, position the two inner sides (using a screwdriver to release them at the bottom) to fit the paper used (Fig. 3-12):
- on the inner guides (1), for A4 format
  - on the outer guides (2), for LETTER and LEGAL formats



**Fig. 3-12 Preparing the automatic sheet feeder**

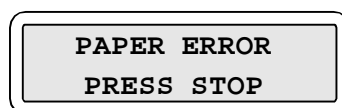
- 2) Reassemble the cover and insert the ASF in its housing, then tilt the cover forward and load the paper of the desired size (max 70 sheets)(Fig. 3-13)





**Fig. 3-13 Inserting the ASF and the paper**

- 3) Close the cover of the ASF and set the **FORMAT** parameter in the **PRINTER PARAMETERS** menu to the value that **corresponds to the size of the paper and width of the tray** (see section 3.2.1).
- 4) Make a copy to check that the job has been carried out correctly: if any of the factors do not coincide, the following message will appear:





- 5) To eliminate the error, proceed as follows:
  - switch off the facsimile machine
  - remove the ASF and check that the distance between the inner sides corresponds to the width of the paper used
  - power on the facsimile machine and check that the **FORMAT** parameter corresponds to the previous setting made
  - reinsert the ASF.

### **3.1.7 Feeding special papers manually on the LinkFax model**

When you use the LinkFax model as a printer, the following special papers can be used: **Transparency film** (with backing), **Transparency film with border**, **Glossy paper**, **Coated paper**, and **Thick paper**.

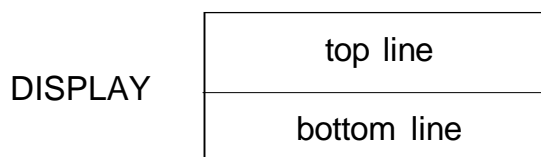
If the paper to be used is not easily fed into the facsimile machine (i.e. it is too thick, too heavy or too smooth, as when **transparency films with border** and **thick paper** are used), it is necessary to feed it manually (see chapter 10, Using the facsimile machine as a printer, Printing with LinkFax 8).

## 3.2 INSTALLING AND SETTING UP THE MACHINE

The procedures used for installing and setting up the machine may be divided into *indispensable* procedures (marked by the background ) and procedures that *depend on the characteristics of the telephone exchange or the user's requirements* (marked by the background )

### 3.2.1 Organization of the Installation and Setup Parameters

The *installation and setup* parameters are organized into *menus* and *submenus*, shown on the display as follows:



- the *top line* is used for displaying:
  - *menu* and *submenu* items, which represent the operating selections available on the facsimile machine
  - *parameters*, to which a value is to be assigned to make an operating selection
- the *bottom line* is used for displaying the *keys that handle* the items indicated on the top line, that is:

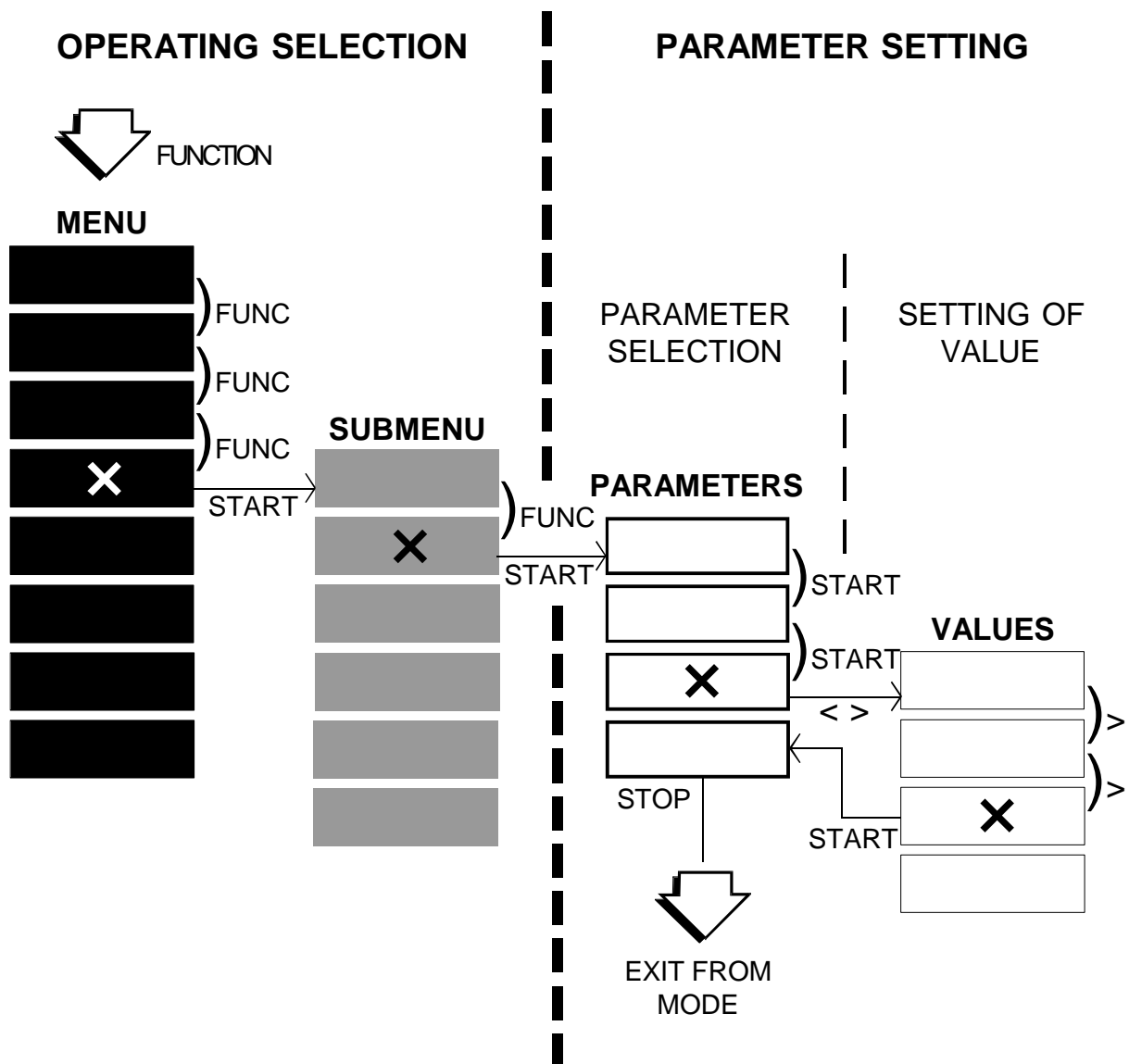
**FUNCTION** for *selecting menu* and *submenu* items, which can be scrolled cyclically *forwards only*, i.e. from the first to the last and then skipping straight back to the first again

**START** for *confirming menu* and *submenu* items, *parameters* and *values*:

- by confirming a *menu*, you access the corresponding *submenu*
- by confirming a *submenu*, you access the corresponding *parameters*
- by confirming a *parameter* or its *value*, you access the *next parameter*

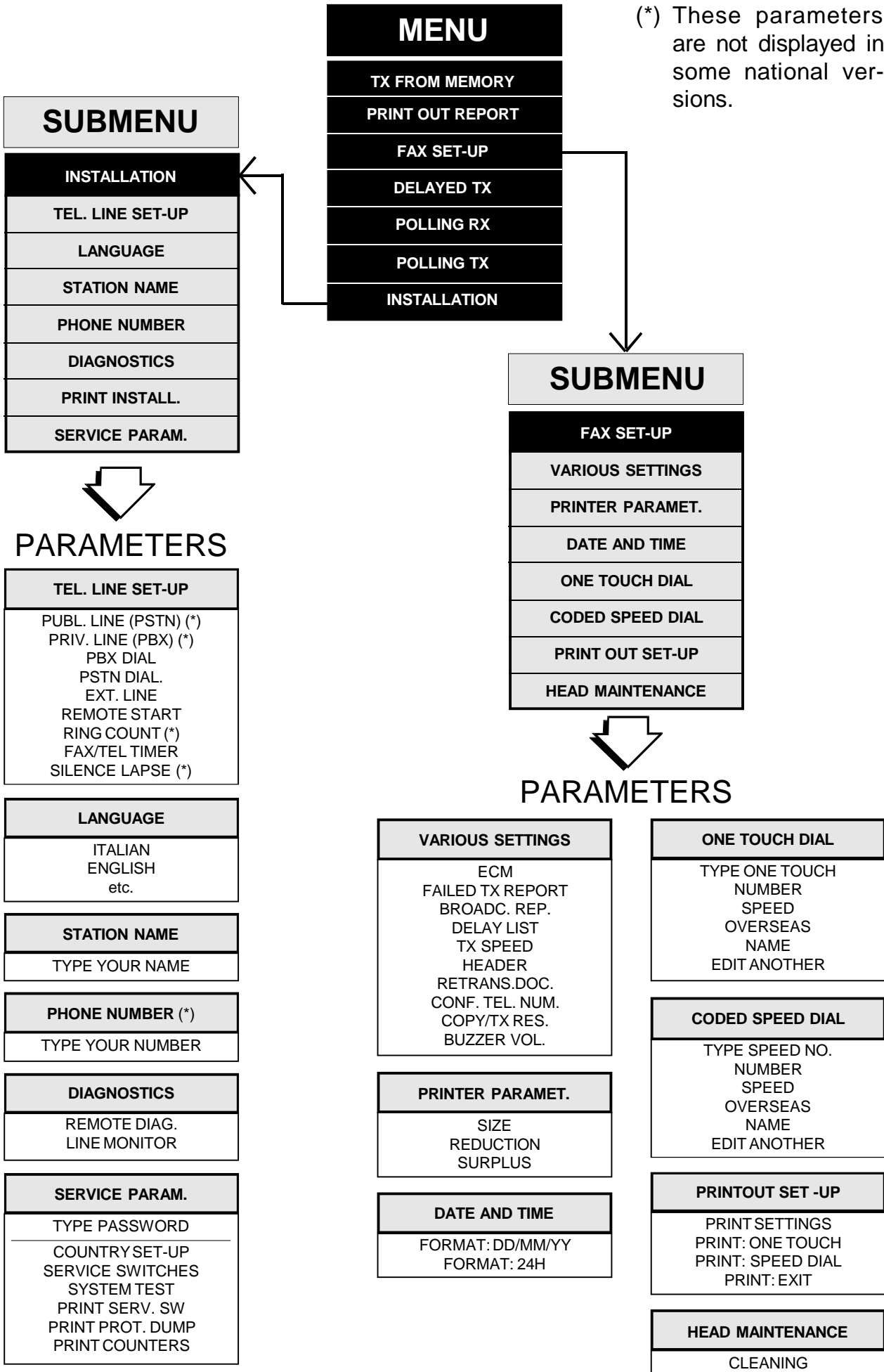
- < > for **selecting the values** of a parameter, scrolling forwards and backwards through those available on the machine, or for **moving** along the characters that make up the parameter value. In the latter case, the value must then be **set** using the numeric keypad
- STOP** for **exiting from installation or setup mode.**

A schematic diagram of parameter management is provided below:



The figure that follows provides a detailed illustration of the organization of the installation and setup parameters.

(\*) These parameters are not displayed in some national versions.



## 3.2.2 Setting the Country Parameters

This procedure enables you to adapt some specific parameters automatically to the values preset for a particular country.

Setting	Display
a) The facsimile machine is in stand-by mode	AUTOMATIC RX 09-05-95 14:58
b) Press <b>FUNCTION</b> to access the main menu	FAX SET-UP FUNC/START/STOP
c) Select the SERVICE SWITCHES submenu of the INSTALLATION menu.	SERVICE SWITCHES FUNC/START/STOP
d) Press <b>START</b>	TYPE PASSWORD ⌘
e) Enter the number <b>1 1 0 0</b> and press <b>START</b> to enter " <b>service</b> " mode	COUNTRY SETUP START/STOP/↵/Ⓜ
f) Press <b>START</b> to confirm the COUNTRY SETUP item	AMERICA START/STOP/↵/Ⓜ
g) Select the desired country (for example, <b>U.K.</b> ), and then press <b>START</b> : the values for the selected country are automatically loaded, then the facsimile machine returns to stand-by mode.	U.K. START/STOP/↵/Ⓜ
	AUTOMATIC RX 09-05-95 14:58

**WARNING:** After setting the country parameters it is possible, whenever necessary, to reload the default values for the current country, by means of the following simplified procedure;

- press in rapid sequence **STOP # #**
- press **START**.

COUNTRY SETUP  
START/STOP/↵/Ⓜ

AUTOMATIC RX  
09-05-95 14:58

### 3.2.3 Storing the User's Number and Name

Setting	Display
a) The facsimile machine is in stand-by mode	<div style="border: 1px solid black; padding: 5px; width: fit-content; margin: auto;">           AUTOMATIC RX            09-05-95 14:58         </div>
b) Access the main menu and select the STATION NAME item on the INSTALLATION menu	<div style="border: 1px solid black; padding: 5px; width: fit-content; margin: auto;">           STATION NAME            FUNC/START/STOP         </div>
c) Press <b>START</b>	<div style="border: 1px solid black; padding: 5px; width: fit-content; margin: auto;">           TYPE YOUR NAME            ☎         </div>
d) Enter the user's <i>mnemonic ID</i> :	
<ul style="list-style-type: none"> <li>- you can use a <b>maximum of 16 alphanumeric characters</b></li> <li>- select <b>one character at a time</b> using the numeric keys, as shown below:</li> </ul>	
key 1, characters: 1 key 2, characters: 2 A B C key 3, characters: 3 D E F key 4, characters: 4 G H I key 5, characters: 5 J K L key 6, characters: 6 M N O key 7, characters: 7 P R S key 8, characters: 8 T U V key 9, characters: 9 W X Y key 0, characters: 0 Q Z key *, characters: <b>symbols</b> (selected "forwards") key #, characters: <b>symbols</b> (selected "backwards")	Example  <div style="border: 1px solid black; padding: 5px; width: fit-content; margin: auto;">             TYPE YOUR NAME              JOHN           </div>
<ul style="list-style-type: none"> <li>- each key selects the characters <b>cyclically</b>, starting from the numeric character and displaying each of the other characters when pressed</li> <li>- to change a <b>capital letter</b> into a <b>lower case letter</b>, or vice versa, press the key <b>A*</b> <b>a</b> after entering it: the new mode will remain set until the same key is pressed again.</li> <li>- confirm the character selected by pressing the <b>&gt;</b> key: the cursor will move one place to the right</li> <li>- to correct an error, move the cursor to the character to be changed using the <b>&gt;</b> and <b>&lt;</b> keys, and select the desired character.</li> </ul>	

Setting	Display
<ul style="list-style-type: none"> <li>- to delete the entire entry, press <b>CLEAR</b></li> <li>- having made the entry, press <b>START</b> to access the PHONE NUMBER item</li> </ul>	<div style="border: 1px solid black; padding: 5px; width: fit-content; margin: auto;">PHONE NUMBER FUNC/START/STOP</div>
e) Press <b>START</b>	<div style="border: 1px solid black; padding: 5px; width: fit-content; margin: auto;">TYPE YOUR NUMBER ☎</div>
f) Enter your <i>number</i> .	<p>Example</p> <div style="border: 1px solid black; padding: 5px; width: fit-content; margin: auto;">TYPE YOUR NUMBER +39 125 524598</div>
<ul style="list-style-type: none"> <li>- you can enter a <b>maximum of 16 characters</b> using the <b>numeric keys</b> (0 ÷ 9), the *key (to enter the + character) and the &gt; key (to enter a space)</li> <li>- to correct or delete, proceed as for the mnemonic ID</li> <li>- having made the entry, press <b>START</b></li> </ul>	<div style="border: 1px solid black; padding: 5px; width: fit-content; margin: auto;">DIAGNOSTICS FUNC/START/STOP</div>
g) Press <b>STOP</b> to return to stand-by mode.	<div style="border: 1px solid black; padding: 5px; width: fit-content; margin: auto;">AUTOMATIC RX 09-05-95 14:58</div>

### 3.2.4 Setting Up the Telephone Line

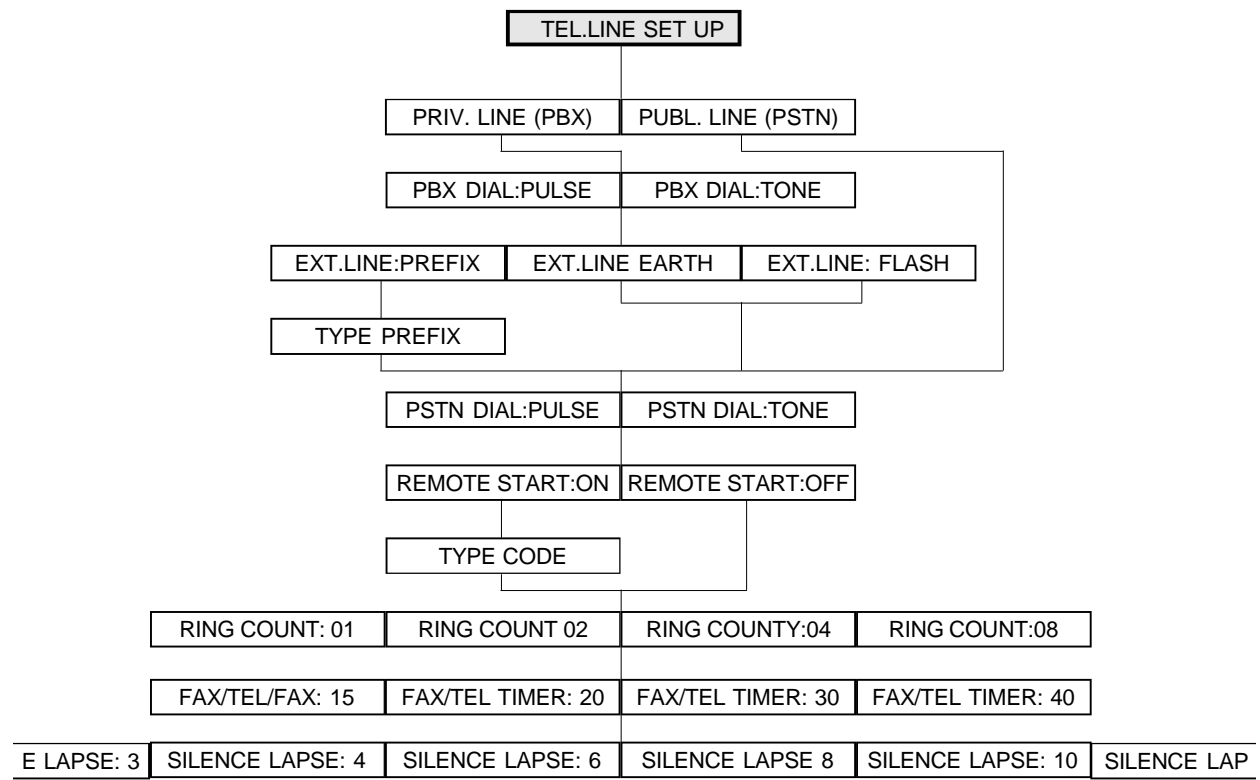
According to the type of network to which the facsimile machine is connected (PUBLIC NETWORK or PRIVATE BRANCH EXCHANGE), the following specific parameters must be set:

- type of **dialling** (established by the Telephone Service Manager):
  - **tone** (or **multifrequency**) (PBX/PSTN DIAL: TONE)
  - **pulse** (PBX/PSTN DIAL: PULSE)
- type of **access** from private line to public line:
  - numeric **prefix** (EXT. LINE: PREFIX)
  - **earth pulse** (EXT. LINE: EARTH)
  - **flash pulse** (EXT. LINE: FLASH).

In addition to these indispensable parameters, the following parameters may also be set:

- **enabling of extension telephone** for activating the facsimile machine ( REMOTE START), **by means of a one-digit code** (0-9)
- **number of rings** after which the facsimile machine prepares for automatic reception (RING COUNT: 01 / 02 / 04 / 08)
- **time** (in **seconds**) after which the facsimile machine with the fax/phone feature enabled **switches to fax mode** (FAX/TEL TIMER: 15 / 20 / 30 / 40)
- **time** (in **seconds**) after which the facsimile machine connected to an external telephone answering machine **switches to fax mode**, when there is no incoming message (SILENCE LAPSE: 3 / 4 / 6 / 8 / 10 / NO).

Setting	Display
a) The facsimile machine is in stand-by mode	<div style="border: 1px solid black; padding: 5px; width: fit-content; margin: auto;">           AUTOMATIC RX            09-05-95 14:58         </div>
b) Access the main menu and select the TEL.LINE SETUP submenu of the INSTALLATION menu.	<div style="border: 1px solid black; padding: 5px; width: fit-content; margin: auto;">           TEL.LINE SETUP            FUNC/START/STOP         </div>
c) Press <b>START</b>	<div style="border: 1px solid black; padding: 5px; width: fit-content; margin: auto;">           PUBL.LINE (PSTN)            START/STOP/- /®         </div>
d) Set the parameters to the desired values, following the explanatory flow chart shown below:	



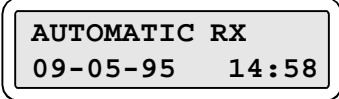
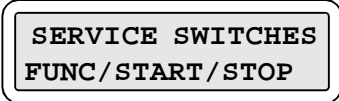
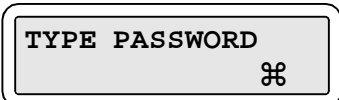
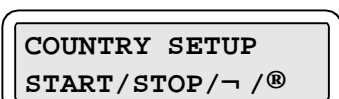
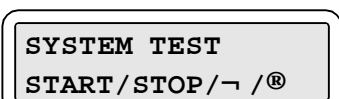

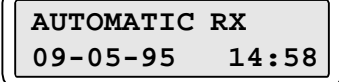


### 3.2.5 Completing Installation

Installation may be completed by setting the FAX SET-UP to suit the user's needs. See the User Manual for a description of the procedure to be followed.

### 3.2.6 Resetting the Fax Machine

Having installed the machine, if it does not work properly in reception and transmission, reset the parameters to restore the default values and repeat the installation procedure from the start.

Setting	Display
a) The facsimile machine is in stand-by mode	
b) Access the main menu and select the SERVICE SWITCHES submenu of the INSTALLATION menu.	
c) Press <b>START</b>	
d) Enter the number <b>1 1 0 0</b> and press <b>START</b> to enter " <b>service</b> " mode	
e) Select the SYSTEM TEST item and press <b>START</b>	
f) Select LOAD DEFAULT and press <b>START</b> twice: the default values for U.K./SOUTH AFRICA are loaded automatically in place of those set previously	
g) Press <b>STOP</b> to return to stand-by mode.	

**WARNING:** having installed the machine successfully, *never repeat the reset procedure* or you will have to reset all personal data set by the user.

## 4. SERVICE SWITCHES

The term **service switches** is intended to mean parameters that **cannot be accessed by the user** and that can **only be accessed by service technicians** with the facsimile machine in "**service**" mode (see section 3.2.2).

These parameters are given **default values** which depend on the country specifications made by the telephone network manager. As a result, the technician should only change these values in order to correct the functioning of the machine or to adapt it to particular local features.

Before changing any of the service switch settings, it is advisable to print them, as described below:

Setting	Display
a) The facsimile machine is in standby mode	<div style="border: 1px solid black; padding: 5px; width: fit-content; margin: auto;">           AUTOMATIC RX            09-05-95 14:58         </div>
b) Access the main menu and select the SERVICE SWITCHES submenu of the INSTALLATION menu	<div style="border: 1px solid black; padding: 5px; width: fit-content; margin: auto;">           SERVICE SWITCHES            FUNC/START/STOP         </div>
c) Press <b>START</b>	<div style="border: 1px solid black; padding: 5px; width: fit-content; margin: auto;">           TYPE PASSWORD  <span style="float: right;">Z</span> </div>
d) Enter the number <b>1 1 0 0</b> and press <b>START</b> to enter " <b>service mode</b> "	<div style="border: 1px solid black; padding: 5px; width: fit-content; margin: auto;">           COUNTRY SETUP            START/STOP/↵/®         </div>
e) Select the PRINT SERV. SW option	<div style="border: 1px solid black; padding: 5px; width: fit-content; margin: auto;">           PRINT SERV. SW            START/STOP/↵/®         </div>
f) Press the <b>START</b> key: the <b>current default values</b> will be printed (see fig. 4-1)	<div style="border: 1px solid black; padding: 5px; width: fit-content; margin: auto;">           PRINTING...  <span style="float: right;">STOP</span> </div>
g) Press <b>STOP</b> to return to standby mode.	<div style="border: 1px solid black; padding: 5px; width: fit-content; margin: auto;">           AUTOMATIC RX            09-05-95 14:58         </div>

---

SERVICE SWITCHES

U.K./S. AFRICA

SW01	01000101
SW02	00100100
SW03	10000010
SW04	00000000
SW05	01100111
SW06	00101011
SW07	00000000
SW08	00010001
SW09	10101100
SW10	10101111
SW11	00000101
SWA	0
SWB	2
SWC	10
SWD	10
SWE	70
SWF	10
SWG	10
SWH	10 db
SWI	16
SWJ	63
SWK	7
SWL	4
SWM	15
SWN	10
SWO	6
SWP	70
SWQ	3
SWR	120

---

**Fig. 4-1 Example of a printout of the service switch settings**

Two types of service switches are available in the SERVICE SWITCHES menu:

- **SW01 - SW11:** these switches consist of **8 bits** and can be programmed either individually or in group
- **SWA - SWR:** these switches consist of a **value ranging from 1 to 3 digits**

SERVICE SWITCHES

SW01      01010101

bit no. 76543210

SERVICE SWITCHES

SWR              120

- Warning:**
- 1) Whenever **no value** is printed in correspondence with a service switch **SWA-SWR**, this means that the value is **0** (zero).
  - 2) Some of the service switches can be set by the user; in these cases, the **user setting takes priority** over the service setting. The parameters concerned are:

User parameter	Software parameter
RING COUNT	SWB
FAX/TEL TIMER	SWM
SILENCE LAPSE	SWO

## 4.1 SERVICE SWITCH TABLES

The tables that follow describe the functions carried out by the bits and combinations of bits for each service switch. In order to correctly interpret some of the functions required, a knowledge of the communication protocol is required. The default values may undergo some modifications due to both homologation and user's peculiarities. For this reason, you are recommended to print out the service switches of the facsimile machine to be serviced, always before modifying them.

### Switch SW01

bit	Function	set to 1	set to 0
7	Error code generated on failed reception	YES	NO
6	Next page sent from the ADF or resent from memory despite bad reception signal (RTN) from the receiver	YES	NO
5 4	Multifrequency output level (dBm)	bit 5 4 = 0 0, -11 / -9 bit 5 4 = 0 1, -8 / -6 bit 5 4 = 1 0, -12 / -10 bit 5 4 = 1 1, -10 / -8	
3 2	Cable equalizer in reception (radius of cable = 0.4 mm)	bit 3 2 = 0 0, 0 km (0 dB) bit 3 2 = 0 1, 1.8 km (4 dB) bit 3 2 = 1 0, 3.6 km (8 dB) bit 3 2 = 1 1, 5.6 km (12 dB)	
1 0	Cable equalizer in transmission (radius of cable = 0.4 mm)	bit 1 0 = 0 0, 0 km (0 dB) bit 1 0 = 0 1, 1.8 km (4 dB) bit 1 0 = 1 0, 3.6 km (8 dB) bit 1 0 = 1 1, 5.6 km (12 dB)	

## Switch SW02

bit	Function	set to 1	set to 0
7	Answer to second signal from the receiver (anti-echo device)	YES	NO
6 5 4	Tone duration / pause in tone dialling (ms / ms)	bit 6 5 4 = 0 0 0, 70 / 70 bit 6 5 4 = 0 0 1, 70 / 140 bit 6 5 4 = 0 1 0, 87 / 87 bit 6 5 4 = 0 1 1, 120 / 120 bit 6 5 4 = 1 0 0, 200 / 200	
3	Disable non standard features (NSF)	YES	NO
2	Reception start speed	9600-2400 (V.29,V.27ter)	4800-2400 (V.27ter only)
1 0	Transmission start speed	bit 1 0 = 0 0, 9600 bps bit 1 0 = 0 1, 7200 bps bit 1 0 = 1 0, 4800 bps bit 1 0 = 1 1, 2400 bps	

## Switch SW03

bit	Function	set to 1	set to 0	
7	Page loss when SURPLUS = AUTO	12 mm	8 mm	
6	Automatic transmission in HOOK mode without pressing START at the end of dialling	YES	NO	
5	Transmission of the tone emitted by the receiver during reception (CED)	NO	YES	
4	Anti-echo protect tone in transmission	YES	NO	
3	Reception sensitivity	-47 dBm	-43 dBm	
2 1	Wait time for signal from receiver during transmission	bit 2 1 = <b>0 0</b> , 35 s (*) bit 2 1 = <b>0 1</b> , 60 s (*) bit 2 1 = <b>1 0</b> , 90 s (*) bit 2 1 = <b>1 1</b> , 130 s (*)		
0	Frequency of the tone emitted by the receiver during reception (CED)	1100 Hz	2100 Hz	

(\*) In some countries these bits are set to a single specific value.

## Switch SW04

bit	Function	set to 1	set to 0
7 6	Reception channel evaluation criteria	bit 7 6 = <b>0 0</b> , strict bit 7 6 = <b>0 1</b> , average bit 7 6 = <b>1 0</b> , moderate bit 7 6 = <b>1 1</b> , loose	
5	Pause between digits in pulse dialling	800 ms	900 ms
4 3	Dial pulses (N = digits dialled)	bit 4 3 = <b>0 0</b> , N bit 4 3 = <b>0 1</b> , N + 1 bit 4 3 = <b>1 0</b> , 10 - N	
2	Pulse dialling frequency	20 p/s (*)	10 p/s
1	Report printing inhibited	always	(**)
0	PBX dialling tone detection	YES	NO

(\*) only valid if the value of switch SWP is halved.

(\*\*) as programmed via TX REPORT user parameter.

## Switch SW05

bit	Function	set to 1	set to 0
7	Earth pulse duration	100 ms	300 ms
6	Flash pulse duration	110 ms	270 ms
5 4	Pause time	bit 5 4 = <b>0 0</b> , 2 s bit 5 4 = <b>0 1</b> , 3 s bit 5 4 = <b>1 0</b> , 4 s bit 5 4 = <b>1 1</b> , 5 s	
3	PAUSE key enabling	NO	YES
2	Limit to the number of pauses that may be inserted	unlimited number	for 11 s max
1 0	Predialling pause (*)	bit 1 0 = <b>0 0</b> , 1 s bit 1 0 = <b>0 1</b> , 2 s bit 1 0 = <b>1 0</b> , 3 s bit 1 0 = <b>1 1</b> , 4 s	

(\*) only valid if dial tone detection is not enabled (SW06, bit 2 = 0).



## Switch SW06

bit	Function	set to 1	set to 0
7 6	Dialling tone frequency range	bit 7 6 = <b>0 0</b> , 320 / 570 Hz bit 7 6 = <b>0 1</b> , 360 / 520 Hz bit 7 6 = <b>1 0</b> , 300 / 640 Hz bit 7 6 = <b>1 1</b> , 300 / 640 Hz	
5 4 3	Dialling tone detection time	bit 5 4 3 = <b>0 0 0</b> , 400 ms bit 5 4 3 = <b>0 0 1</b> , 800 ms bit 5 4 3 = <b>0 1 0</b> , 900 ms bit 5 4 3 = <b>0 1 1</b> , 1200 ms bit 5 4 3 = <b>1 0 0</b> , 1800 ms bit 5 4 3 = <b>1 0 1</b> , 2000 ms	
2	PSTN dialling tone detection	YES	NO
1	Shortcircuit between digits in pulse dialling	YES	NO
0	Shortcircuit time on relay, before and after dialling pulse	260 / 70 ms	86 / 48 ms

## Switch SW07

bit	Function	set to 1	set to 0
7	Busy tone detected after dialling	YES	NO
6	Exchange tones detected during preliminary phase of reception	YES	NO
5	Rapid preamble recognition during the handshake phase	YES	NO
4	Minimum memory space reserved to receiving	128 kbytes	17 kbytes
3	Report always printed on failed transmission	YES	NO
2	Busy tone seek time after dialling	20 s	standard (*)
1	Frequency range of second dialling tone	1120:1160 Hz Belgian type	as for the 1st dialling tone
0	Dialling tone wait time	40 s	10 s

(\*) i.e., as established by the couple of bits 1 and 2 of switch SW03.

## Switch SW08

bit	Function	set to 1	set to 0
7	Full line monitoring	YES	NO
6	Transmission retries limited within a fixed time range (*)	YES	NO
4 5	Dialling tone detection threshold	bit 5 4 = <b>0 0</b> , -40 dBm bit 5 4 = <b>0 1</b> , -30 dBm bit 5 4 = <b>1 0</b> , -26 dBm bit 5 4 = <b>1 1</b> , -35 dBm	
3	Line feed (*)	1/300"	1/150"
2	Exit from HOOK mode	after 1 h	after 1 min
1	Busy tone detected before dialling	YES	NO
0	Busy tone sequence	4 sequences	2 sequences

(\*) LinkFax model, only

## Switch SW09

bit	Function	set to 1	set to 0
7	Switching off ERROR LED	manual	automatic after 1 min
5 6	Maximum reception/transmission time for one page	bit 6 5 = 0 0, 8 min bit 6 5 = 0 1, 16 min bit 6 5 = 1 0, 32 min bit 6 5 = 1 1, unlimited	
4	Size of data block packets in ECM	64 bytes (*)	256 bytes
3	Compression method	MR & MH	MH
2	Print chart enabled	YES	NO
1	Frequency and sequence of answer tone in FAX/TEL mode	Type B (**)	Type A (***)
0	Extended error codes	YES	NO

(\*) only to be used on lines with interference

(\*\*) Frequency: 425 Hz

Sequence: 

(\*\*\*) Frequency: 700 Hz

Sequence: 

**Switch SW10** (to enable / disable user-level functions)

<b>bit</b>	<b>Function</b>	<b>set to 1</b>	<b>set to 0</b>
<b>7</b>	Change in dialling mode by pressing the ★ key disabled	YES	NO
<b>6</b>	MMR compression method (*)	YES	NO
<b>5</b>	Enable remote diagnostics	YES	NO
<b>4</b>	Set number of rings	YES	NO
<b>3</b>	Enable pulse mode during dialling	YES	NO
<b>2</b>	Set silence time detection	YES	NO
<b>1</b>	FAX/TEL switch	YES	NO
<b>0</b>	Set call time in FAX/TEL mode	YES	NO

(\*) LinkFax model, only

**Switch SW11** (to enable / disable user-level functions)

<b>bit</b>	<b>Function</b>	<b>set to 1</b>	<b>set to 0</b>
<b>7</b>	Enable FAX/TAD	NO	YES
<b>6</b>	Not used		
<b>5</b>	Reserved		
<b>4</b>	Protection for telephone credit card (*)	YES	NO
<b>3</b>	How the console key names are displayed	always in English	in the selected language
<b>2</b>	Linking between letters and numeric keys	fixed to 1 (never set to 0)	
<b>1</b>	Disable "second tone" function of HOLD - 2.TONE key	NO	YES
<b>0</b>	Enable entry of sender's number	YES	NO

(\*) In order to prevent the secret card code from being either displayed or printed, only the last 10 digits of the telephone number are displayed or printed.

### Switch SWA

Format	Function
1 digit (0 ÷ 9)	Time before answering (in seconds)

### Switch SWB

Format	Function
2 digits (01 ÷ 10)	Number of rings before answering

### Switch SWC

Format	Function
max 3 digits (001 ÷ 255)	First ring detection time (in tens of ms)

### Switch SWD

Format	Function
max 3 digits (001 ÷ 255)	Second ring detection time (in tens of ms)

### Switch SWE

Format	Function
max 3 digits (001 ÷ 255)	Ring reset time (in hundreds of ms)

### Switch SWF

Format	Function
max 2 digits (00 ÷ 15)	Maximum percentage of incorrect lines on a page without an error message (00 = function disabled)

### Switch SWG

Format	Function
max 2 digits (00 ÷ 15)	Maximum number of incorrect lines on a page without an error message (00 = function disabled)

### Switch SWH

Format	Function
max 2 digits (00 ÷ 15) (*)	Transmission level code (in dBm)

(\*) 03 ÷ 15 for Italy.

### Switch SWI

Format	Function
max 3 digits (010 ÷ 100)	Minimum ring duration (in ms)

### Switch SWJ

Format	Function
max 3 digits (010 ÷ 100)	Maximum ring duration (in ms)



### Switch SWK

---

<b>Format</b>	<b>Function</b>
max 2 digits (00 ÷ 99)	Number rings before answering in manual reception mode (00 = no answer in manual RX)

---

### Switch SWL

---

<b>Format</b>	<b>Function</b>
max 2 digits (01 ÷ 99)	Wait time of the tone emitted by the sender before alarm to the operator in FAX/TEL mode (in seconds)

---

### Switch SWM

---

<b>Format</b>	<b>Function</b>
max 2 digits (01 ÷ 99)	Alarm duration in FAX/TEL mode (in seconds)

---

### Switch SWN

---

<b>Format</b>	<b>Function</b>
max 2 digits (01 ÷ 99)	Time between two calls while broadcasting (in seconds)

---

### Switch SWO

---

<b>Format</b>	<b>Function</b>
max 2 digits (01 ÷ 59)	Silence recognition time in FAX/TAD mode (in seconds)

---

### Switch SWP

Format	Function
max 2 digits (50 ÷ 80)	Break time in pulse dialling (in ms) (*)

(\*) with a pulse dialling frequency of 20 p/s, halve the value used with the 10 p/s frequency.

### Switch SWQ

Format	Function
max 2 digits (00 ÷ 99)	Number of redials

### Switch SWR

Format	Function
max 3 digits (000 ÷ 999)	Time between redials (in seconds) (000 = no redials)

# 5. DIAGNOSTICS

## 5.1 SELF-DIAGNOSTICS

The facsimile machine ***automatically runs a diagnostic program*** (SELF-DIAGNOSTIC TEST) the first time it is powered on and on reactivation after a power failure or disconnection from the mains:

- if the self-diagnostic test is ***passed***, the facsimile machine enters ***standby mode***
- if the self-diagnostic test is ***failed*** as a result of a ***correctable error***, the facsimile machine displays an ***error code*** on the display.

If this occurs, you must always ***replace the motherboard***, unless a keyboard error occurs (in this case you must replace the console board or the flat cable that connects it to the motherboard).

The self-diagnostic routine tests the following components:

- EPROM
- keyboard
- printer.

The self-diagnostic test stops at the first test in which a fault is detected.

## 5.1.1 Description of the Self-Diagnostic Program

Diagnostic step	Error message
1) The facsimile machine is powered on: the error LED lights up.	
2) The EPROM is tested.	SYSTEM ERROR 93
3) The keyboard RAM is tested.	SYSTEM ERROR 06
4) The keyboard EPROM is tested.	SYSTEM ERROR 07
5) The display is tested.	SYSTEM ERROR 08
6) Communication between the keyboard and motherboard is tested.	SYSTEM ERROR 09
7) Printer startup: check that the print carriage is reset.	SYSTEM ERROR 03 (*)
8) The paper edge sensor is tested.	SYSTEM ERROR 04
9) The position of the print carriage is tested.	SYSTEM ERROR 05
10) The facsimile machine enters stand-by mode: the error LED gets off.	AUTOMATIC RX 09-05-95 14:58

(\*) This error also occurs if the print head is mounted the wrong way round, that is, with the contacts facing the rear; consequently, start by checking that the print head is positioned correctly.

## 5.2 ERROR CODES

The error codes are *printed* on the journals (see section 5.3).

The format of these error codes, excluding those referring to the self-diagnostic test (described in section 5.1.1), may be:

- one group of two digits (**xx**)
- two groups of two digits separated by a dot (**xx.xx**); this extended format:
  - indicates the **category** to which the error belongs, by means of the **first group**:

01	Document incorrectly positioned
02	Unable to connect
03	No answer from correspondent
04	Failed transmission
05	Incomplete transmission
07	Document too long
08	Document jam
10	Failed or incomplete reception
11	No reception due to memory full
13	Failed polling reception
16	Power failure
  - provides **more detailed information** about the error, by means of the **second group**, and may be requested by the technician with the machine in "service" mode (see section 3.2.2), by setting **bit 0** of switch **SW09** to **1** (see section 4.1).

In the tables that follow, the error codes are indicated in their **extended format** and in **ascending numeric order**.

For an explanation of the meaning of the protocol signal codes that appear in the description of the causes of errors, see the next section (5.2.1).

**Important:** to ensure correct identification of the cause of the error, we recommend you always print the communication protocol (PROTOCOL DUMP, see section 5.2.3).

## 5.2.1 Meaning of Protocol Signal Codes

<b>Code</b>	<b>Name</b>	<b>Type of signal</b>
CRP	Command Repeat	GENERIC
CED	Called (Station Identification)	
CIG	Calling (Subscriber Identification)	
CSI	Called asubscriber Identification	
DIS	Digital Identification Signal	
NSC	Non-Standard Command	INITIAL IDENTIFICATION
NSF	Non-Standard Facilities	
NSS	Non-Standard Set-up	
TCF	Training Check Frame	
TSI	Transmitting Subscriber Identification	
DTC	Digital Transmit Command	POLLING COMMANDS
DCS	Digital Command Signal	TRANSMISSION COMMANDS
CFR	Confirmation To Receive	PRE-MESSAGE ANSWERS
FTT	Failure To Train	
CTC	Continue To Correct	
EOM	End-of-Message	
EOP	End-of-Procedure	
EOR	End-of-Retransmission	POST-MESSAGE COMMANDS
MPS	Multipage Signal	
PPS	Partial Page signal	

>>

PRI	Procedure Interrupt	
RR	Receive Ready	
<hr/>		
CTR	Response to CTC	
ERR	Response to EOR	
MCF	Message Confirmation	
PIN	Procedure Interrupt Negative	
PIP	Procedure Interrupt Positive	POST-MESSAGE ANSWERS
PPR	Partial Page Request	
RNR	Receive Not ready	
RTN	Retrain Negative	
RTP	Retrain Positive	
<hr/>		
DCN	Disconnect	DISCONNECTION
<hr/>		

## 5.2.2 Meaning of Error Codes

<b>Code</b>	<b>Cause of Error</b>	<b>Action</b>
02.00	Unable to connect	None
03.00	No answer from correspondent	Call again
04.00	No connection due to disconnected correspondent (DCN received)	Call again
04.01	No connection due to incompatible correspondent (during handshake phase)	Call again
04.02	No connection due to incompatible correspondent	Call again
04.03	No connection due to incompatible correspondent (incompatible confirmation signal)	Call again
04.04	No connection due to incompatible correspondent (DCN instead of confirmation signal)	Call again
04.05	Line error as no further speed fall-back is possible	Call again
04.06	No connection due to problems on receiver's side (no answer)	Call again
04.07	No answer during post-message phase	Call again
04.08	Answer not allowed during post-message phase	Call again
04.09	No development of protocol	Call again
04.10	Answer not allowed during post-message phase in ECM	Call again

>>



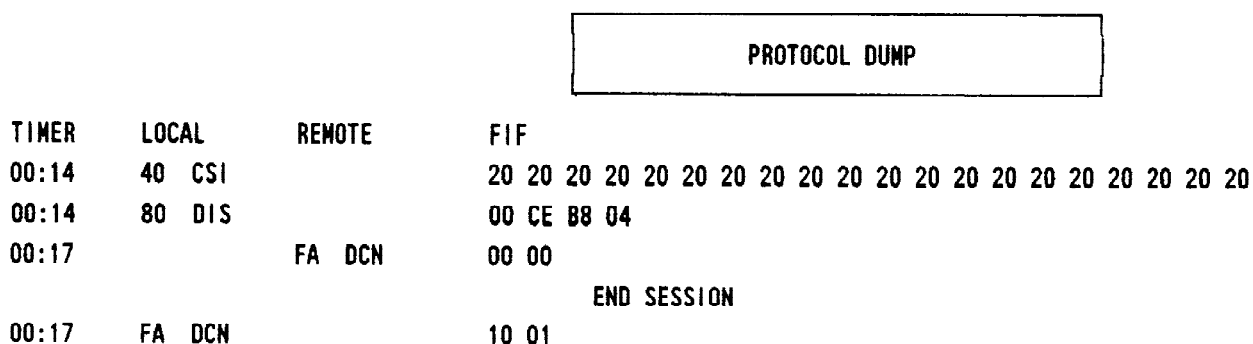
<b>Code</b>	<b>Cause of Error</b>	<b>Action</b>
04.11	No answer during post-message phase in ECM	Call again
04.12	Insufficient memory on receiver's side	Call again
<b>05.00</b>	Transmission incomplete	Call again
<b>07.00</b>	Document too long	Call again
<b>08.00</b>	Document jam	Remove document
<b>09.00</b>	STOP pressed during TX or RX	None
<b>10.00</b>	Text coding error at start of message	None
10.01	No connection due to incompatible correspondent	None
10.02	No reception due to no answer from correspondent during handshake, or at the end of the block, or at the end of a page with change in resolution	None
10.03	Line error due to incompatible speed	None
10.04	No commands received from correspondent	Call again
10.05	Text coding error (5 seconds without data)	None
10.06	No signal during reception of the message	Call again
10.07	No commands received from correspondent at start of message	Call again
10.08	No document present on polling request	None

>>

<b>Code</b>	<b>Cause of Error</b>	<b>Action</b>
10.09	Page received incorrectly (RTN transmitted)	Call again
10.10	No commands received from correspondent at start of message (in ECM)	Call again
10.11	Page received incorrectly in ECM (ERR sent)	Call again
10.12	Busy tone recognized during handshake	Call again
10.13	Text coding error during reception of the message	None
<b>11.00</b>	Riception incomplete due to user memory full	Clear unwanted documents from the memory
11.10	Riception incomplete due to user memory full in ECM	Clear unwanted documents from the memory
<b>13.00</b>	Failed polling reception	Call again
<b>16.00</b>	Power failure	None

## 5.2.3 Printing the Communication Protocol

Setting	Display
1) The facsimile machine is in standby mode.	AUTOMATIC RX 09-05-95 14:58
b) Enter " <b>service</b> " mode and select PRINT PROT. DUMP	PRINT PROT DUMP START/STOP/↵/Ⓜ
c) Make sure that there is paper in the ASF and then press <b>START</b> : the data shown in fig. 5-1 will be printed and then the facsimile machine will return to standby mode.	PRINT PROT.DUMP START/STOP



**Fig. 5-1**

The protocol status is presented, session by session, by means of the following fields:

- TIMER** Indicates the times, in *minutes : seconds*, at which the signals were exchanged during the session
- LOCAL** Indicates the signals, represented by a *hexadecimal code* and a *mnemonic code*, sent by the local facsimile machine
- REMOTE** Indicates the signals sent by the correspondent's facsimile machine
- FIF** Indicates the *structure of the signals* (FIF = Facsimile Information Field) in hexadecimal code.

**Remarks:**

- 1) The LOCAL field, during the session in which the message was sent, indicates the message's **transmission level**, followed by the word **MESSAGE** (fig. 5-2)

---

00:14	43	TSI		20 20 20 20 20 20 20 20 20 20 20 20 20 20 20 20 20 20 20 20
00:14	83	DCS		00 86 F8 04
00:20			84 CFR	
00:21	06	dBm	MESSAGE	
00:38	BF	PPSEOP		00 00 47
00:41			8C MCF	

**Fig. 5-2**

- 
- 2) If there is a data inconsistency error in any session, the LOCAL field contains the message **CRC ERROR**
  - 3) At the end of the session, the FIF indicates the extended code of the **result** of the session (fig. 5-3):

---

00:14	80	DIS		00 CE B8 04
00:17			FA DCN	00 00
				END SESSION
00:17	FA	DCN		10 01

**Fig. 5-3**

- 
- positive result (**00 00**)
  - positive result with document received incorrectly (**00 01**)
  - negative result (**extended error code**, e.g. 10 01)
  - busy status (**06 00**)
  - STOP key pressed status (**09 00**).

## 5.2.4 Printing the Counters

The *counters* store the following statistical information:

<b>TOTAL TX PAGES</b>	total number of <i>transmitted pages</i> , both via ADF and from memory
<b>TOTAL RX PAGES</b>	total number of <i>received pages</i> , included into memory
<b>TOTAL TX TIME</b>	<i>total transmission time</i> (h, m, s)
<b>TOTAL RX TIME</b>	<i>total reception time</i> (h, m, s)
<b>ECM TX PAGES</b>	total number of <i>transmitted pages in ECM</i>
<b>ECM RX PAGES</b>	total number of <i>received pages in ECM</i>
<b>COPIED PAGES</b>	total number of <i>printed pages in copying</i>
<b>TOTAL PRINTED PAGES</b>	total number of <i>printed pages</i> (copying, RX, reports)
<b>FALLBACKS</b>	number of <i>fallbacks</i> in transmission
<b>ERRORS</b>	total number of <i>errors</i> .

Setting	Display
1) The facsimile machine is in standby mode.	AUTOMATIC RX 09-05-95 14:58
b) Enter " <b>service</b> " mode and select PRINT COUNTERS	PRINT PROT DUMP START/STOP/↵/Ⓜ
c) Make sure that there is paper in the ASF and then press <b>START</b> : the data shown in fig. 5-1 will be printed and then the facsimile machine will return to standby mode.	PRINT PROT.DUMP START/STOP

### COUNTERS REPORT

<b>TOTAL TX PAGES:</b>	<b>000000345</b>
<b>TOTAL RX PAGES:</b>	<b>000000534</b>
<b>TOTAL TX TIME:</b>	<b>0000002674</b>
<b>TOTAL RX TIME:</b>	<b>0000009596</b>
<b>ECM TX PAGES:</b>	<b>0000000078</b>
<b>ECM RX PAGES:</b>	<b>0000000076</b>
<b>COPIED PAGES:</b>	<b>0000000025</b>
<b>TOTAL PRINTED PAGES:</b>	<b>0000000544</b>
<b>FALLBACKS:</b>	<b>0000000000</b>
<b>ERRORS:</b>	<b>0000000388</b>

**Fig. 5-4**

## 5.3 REPORTS

The facsimile machine controls and updates various kinds of transaction reports which are described in this section for the technician's benefit, though a more detailed description is provided in the Instruction manual. Some of these reports are printed automatically and others on request by the operator:

- Transmission report (LAST TX REPORT): printed automatically and manually
- Broadcast transmission report (LAST BROAD. REP.): printed automatically and manually
- Journal (ACTIVITY REPORT): printed automatically and manually
- Power failure report: printed automatically only.

A report is printed by selecting the PRINT OUT REPORT option on the main menu (see section 3.2.1).

### 5.3.1 Transmission Report (TX REPORT)

The methods for printing the transmission report (automatically or manually) are selected by means of the SET MISCELLANEOUS option of the FAX SET-UP menu (see section 3.2.1):

- TX REPORT: OFF, if you do **not** want the report to be printed **automatically**
- TX REPORT: ALWAYS, if you want the report to be printed **automatically after each transmission transaction**
- FAILED TX REPORT, if you want the report to be printed **automatically only when an error is detected** (\*).

---

(\*) if bit **3** of switch SW07 is set to **1** (see section 4.1), the report is **always printed** when **transmission is failed** even if the TX REPORT: OFF option is selected.

The transmission report contains the following information (fig. 5-5):

---

LAST TRANSMISSION REPORT		
Act.N.	0004	
Type	TX ECM	
Doc.N		
Dialled Number	0524867	
Received Id		
Date/Time	12-03-95	13:59
Duration	00:31	
Pages	01	
Result	OK	

Fig. 5-5

- **Act. n.** progressive number of activity or transaction (4 digits)
- **Type** transaction (TX / TX ECM / RX / RX ECM / POLL / POLL ECM)
- **Dialled number** correspondent's number dialled
- **Received Id** correspondent's number (and name, if recorded) (\*)
- **Date/Time** date and time of start of transaction
- **Duration** duration of transaction (minutes : seconds)
- **Page** number of pages in document
- **Result** result of transaction (OK / error code).

---

(\*) this is the **ID recorded** on the correspondent's facsimile machine, the numeric part of which should correspond to the **actual telephone number** of the facsimile machine: if it does not, call the correspondent and ask him/her to correct the ID.

### 5.3.2 Broadcast Transmission Report(LAST BROAD. REP.)

The broadcast transmission report contains the same information provided by the activity report, with regard to the correspondents list involved (fig. 5-6):

LAST BROADCAST REPORT									
Act.N.	Type	Doc.N	Dialled Number	Received Id	Date/Time	Duration	Pages	Result	
0005	TX ECN	0001	0524867		12-03-95 14:03	00:28	01	OK	
0006	TX ECN	0001	0524867		12-03-95 14:04	00:28	01	OK	

### 5.3.3 Journal (ACTIVITY REPORT)

Provides information about all transactions (transmission / reception) and is printed **automatically every 30 transactions** (and the information printed is subsequently cleared from the memory) or on request by the operator (fig. 5-7):

ACTIVITY REPORT							
Att.n.	Type	Dialled Number	Received Id	Date/Time	Duration	Page	Result
0005	TX	574412	DFX 3100	12-06-95 15:29	00:56	01	OK
0006	TX	574412	DFX 3100	12-06-95 15:38	00:26	01	09
0007	RX	574412	0039 11 2202662	12-06-95 19:22	00:52	01	OK
0008	TX	574412	DFX 3100	13-06-95 09:37	00:35	01	09
0009	TX	574412	DFX 3100	13-06-95 10:09	00:20	01	09
0010	TX	574412	DFX 3100	13-06-95 10:16	00:21	01	09
0011	TX	574412	DFX 3100	13-06-95 11:37	00:19	01	09
0012	TX	574412	DFX 3100	13-06-95 11:39	00:46	01	OK
0013	TX	574412	DFX 3100	13-06-95 11:43	00:42	01	OK
0014	RX	574412	+39 125 523100	13-06-95 15:10	00:38	01	OK
0015	RX	574412	+39 125 523100	13-06-95 15:14	00:23	01	00
0016	RX	574412		13-06-95 15:17	00:10	00	00
0018	RX	574412	+39 125 523100	13-06-95 15:20	00:23	01	00
0019	RX	574412	+39 125 523100	13-06-95 15:22	00:32	01	OK
0020	RX	574412	+39 125 523100	13-06-95 15:23	00:52	01	OK
0021	RX	574412	+39 125 523100	13-06-95 15:24	00:47	01	OK

Fig. 5-7



### 5.3.4 Power Failure Report

When there is a power failure during a transaction (transmission or reception), a **report** is **automatically** printed out (see fig. 5-8) when normal operation is restored:

---

POWER FAILURE		
Act.n.	0061	
Type	TX	
Dialled Number	574172	
Received Id	+39 125 524172	R&S Doc.Arch.
Date/Time	12-10-95 14:38	
Duration	00:21	
Page	01	
Result	16-00	POWER FAILURE ON PAGE 01

Fig. 5-8

## 5.4 REMOTE DIAGNOSTICS

Remote diagnostics is a **long-distance service** enabling a main station, consisting of a facsimile machine connected to a PC (called a "**master station**"), to perform diagnostic operations on any peripheral facsimile machine in the same family (called a "**slave station**") - providing it has been **enabled** to do so **previously** - to eliminate problems that have arisen on the slave.

This facsimile machine can only be enabled as a "**slave station**" in remote diagnostic sessions, that is:

- **transmit** a series of data that includes the **setup parameters** after a request has been made in polling mode by a "master station"
- have **these parameters changed locally** (i.e. on the "master station")
- **receive the modified data** to replace the current data.

### 5.4.1 Enabling the Facsimile Machine as a "Slave Station"

Enabling the facsimile machine to "slave" operation is possible by setting to **1** the bit **5** of software switch SW10 (see section 4.1).

To use this function, it must be enabled by setting the **REMOTE CONTROL** setup parameter in the DIAGNOSTICS submenu of the main INSTALLATION menu (see section 3.2.1) to **YES**.



# 6. SYSTEM TEST AND ADJUSTMENTS

## 6.1 SYSTEM TEST

The **SYSTEM TEST** is a collection of *utility programs*, which are not available to the user but are provided to enable the service technician to carry out specific **tests** on components and modules.

The system tests are arranged into menus under the SYSTEM TEST item (see section 3.2.1) and can be accessed either with the machine in " **service**" mode (see section 3.2.2) or pressing in rapid sequence **START ★ ★**. ***Underlined tests*** cannot be activated with a colour print head:

- PRINT OUT SET-UP (\*)
- ALIGNMENT TEST
- NOZZLES TEST
- CLEANING
- PRINT CHART
- ASF TEST
- ADF TEST
- SYSTEM TEST MSG (\*)
- MODEM TEST (\*)
- KEYB. SIMULATION (\*)
- RAM TEST (\*)
- AGING TEST (\*)
- FIRMWARE RELEASE (\*)
- LOAD DEFAULT
- SCANNER SHADING
- KEYBOARD TEST (\*)
- DISPLAY TEST (\*)
- CARRIAGE TEST.
- PRINT SIMULATION (\*)
- CLEANER TEST (\*)

**Warning:** each test in progress can be interrupted or terminated in either of the following ways:

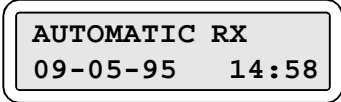



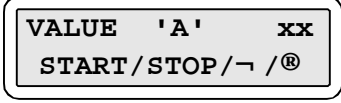
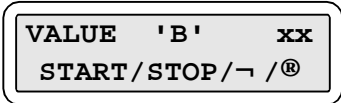
- by pressing **the STOP key once**, if you want **to stay in test mode** (the test that follows the interrupted or terminated one appears on the display)
- by pressing **the STOP key twice**, if you want to exit from test mode and **return to stand-by mode**.

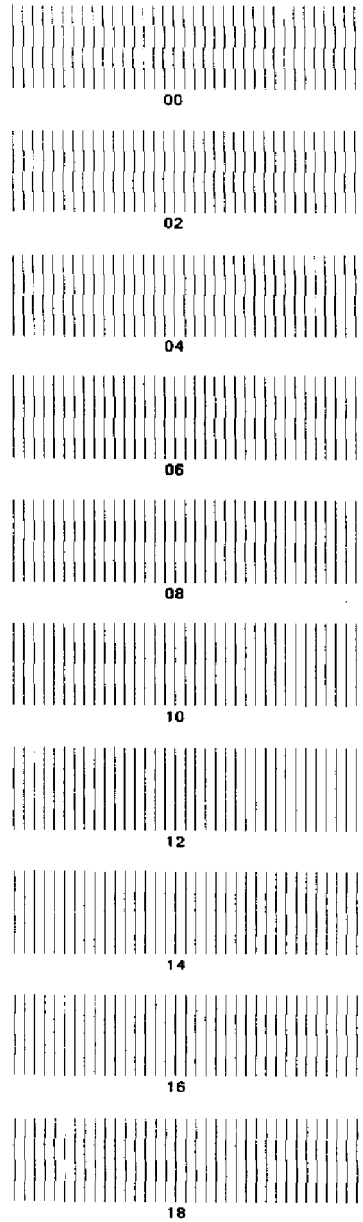
---

(\*) These tests are used exclusively for special production requirements or during laboratory tests and, consequently, no description is provided in this manual.

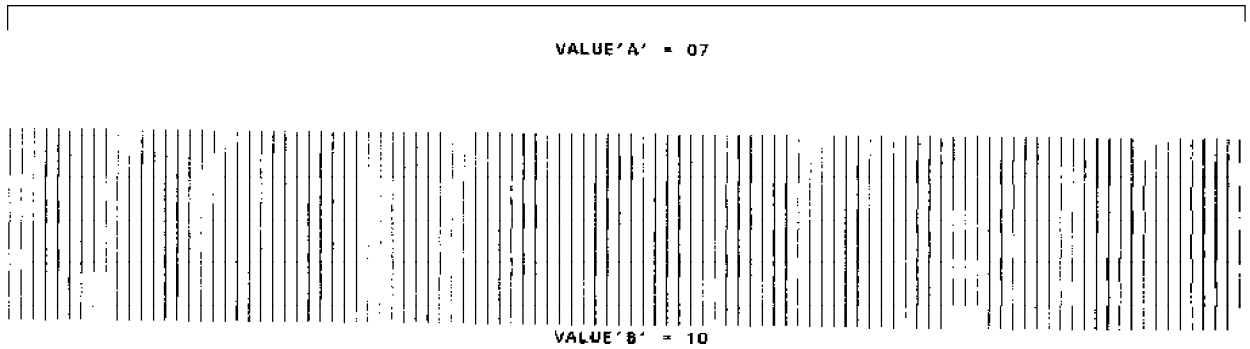
### 6.1.1 ALIGNMENT TEST (not active with a colour print head)

This test **MUST** be carried out after replacing: the printer unit, motherboard, carriage or carriage motor.

Setting	Display
a) The facsimile machine is in standby mode	
b) Get access to the system test menu and select the ALIGNMENT TEST option	
c) Make sure that there is paper in the ASF, and then press <b>START</b> : the test chart shown in fig. 6-1 is printed out	
d) At the end of the printout, the message <b>VALUE 'A' xx</b> will appear on the display; look carefully at the <b>scale</b> printed in the top left corner of the print chart (use a magnifying lens or make an enlarged copy of the scale) and detect the <b>value of its length (from 0 to 15)</b> : 	
e) Enter the detected value as <b>xx</b> (in order to adjust the print left margin) and press <b>START</b> ; the message <b>VALUE 'B' xx</b> will appear on the display: <ul style="list-style-type: none"><li>- identify the <b>best vertical alignment</b> from the ten shown on the test chart</li><li>- enter the <b>number corresponding</b> to the best alignment using the left and right arrow keys; note that an <b>intermediate value</b>, which is not printed on the test chart, may be selected as the best alignment, there are therefore 20 values available (<b>0-19</b>)</li><li>- press <b>START</b>: the test chart in fig. 6-2 showing both the margin alignment (the example shows VALUE 'A' = 07) and the vertical alignment (the example shows VALUE 'B' = 10) is printed out.</li></ul>	



**Fig. 6-1**



**Fig. 6-2**

## 6.1.2 NOZZLES TEST

This test may be carried out to identify the cause of printing errors.

Setting	Display
a) The facsimile machine is in standby mode	AUTOMATIC RX 09-05-95 14:58
b) Get access to the system test menu and select the NOZZLES TEST option	NOZZLES TEST START/STOP/↵/Ⓜ
c) Press <b>START</b> : the test result is immediately displayed	NOZZLES TEST OK START/STOP
	OR
d) Make sure that there is paper in the ASF, and then press <b>START</b> ; if you have installed a <b>monochrome print head</b> , the following chart is printed out (see fig. 6-3):	NOZZLES TEST OK START/STOP

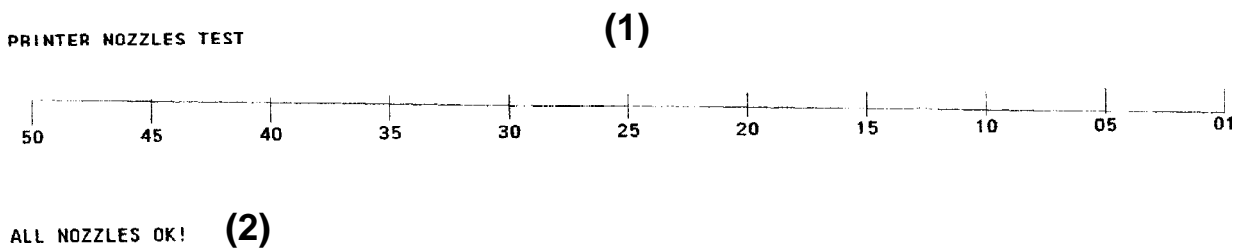


Fig. 6-3

The chart consists of:

- (1) a **numbered scale** for **checking the flow of ink**, with the nozzles numbered from 01 to 50
- (2) a message providing the **result of the test run on the electrical print head circuits**.

If you have installed a **colour print head**, the following chart is printed out (see fig. 6-3a) and consists of:

- (1) the threefold print-out of the **three print head colours** (cyan, magenta, yellow)
- (2) three **numbered scales** for **checking the flow of ink**, with the nozzles numbered (01 to 16 for cyan, 01 to 17 for magenta, 01 to 18 for yellow)

- 3) a message providing the **result of the test run on the electrical print head circuits.**

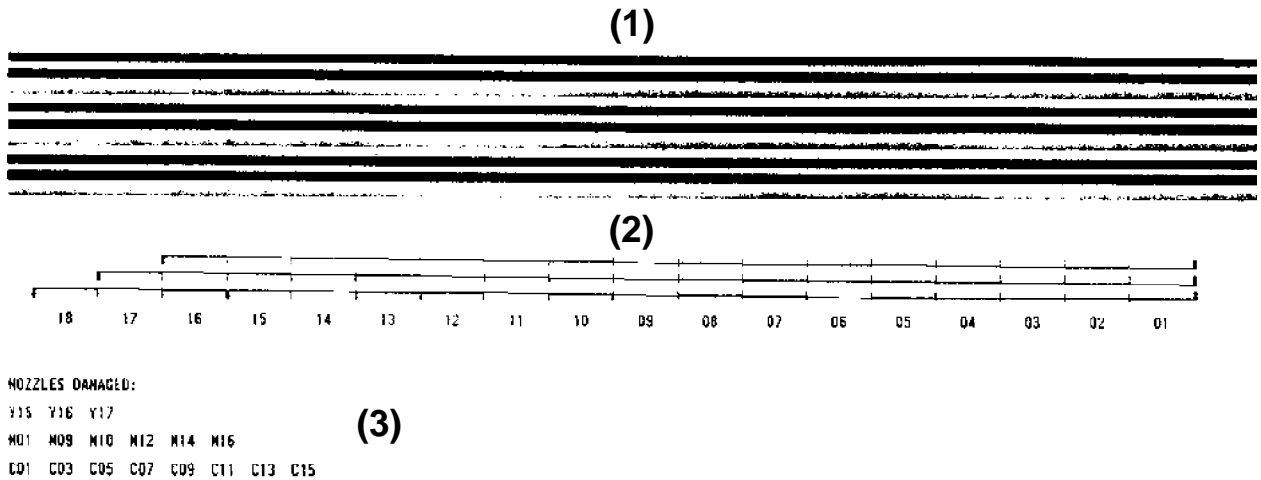


Fig. 6-3a

### 6.1.2.1 Checking the Ink Flow

Check the numbered scale:

- if **all the lines** that make up the scale are **present**, all the nozzles are working
- if **one or more lines are missing**, the fault could be due to one of the following:
  - dirty printing nib: clean the rubber print head pad
  - foreign body on printing nib: remove it taking care to avoid touching the electrical contacts on the print head
  - air bubble in the ink: carry out the CLEANING (see section 6.1.3) followed by the PRINT CHART test (see section 6.1.4); if the fault persists, repeat the CLEANING up to three times, and then replace the print head if this does not have the desired effect.

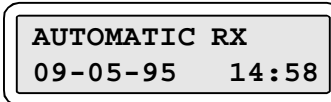
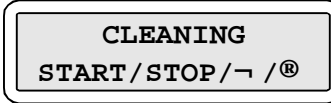

### 6.1.2.2 Checking the Electrical Circuits

Check the message indicating the result of the test:

- ALL NOZZLES OK            all the electrical circuits are working
- NOZZLES DAMAGED:    circuit(s) xx (yy, zz) error: remove the print head, clean the electrical contacts on the print head with a dry swab and the electrical contacts of the print carriage with a soft, dry cloth, then reinsert the print head and repeat the NOZZLES TEST. If another faulty circuit is indicated, reinsert the print head several times until the fault has been eliminated; if the fault persists on the same circuit (xx / yy / zz) after installing a new print head, replace the print carriage (see section 7.2.15).

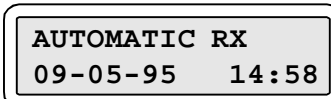
### 6.1.3 CLEANING

This test is used for restoring the print head to efficient operation without replacing it.

Setting	Display
a) The facsimile machine is in standby mode	
b) Get access to the system test menu and select the CLEANING option	
c) Press <b>START</b> : a series of nozzle cleaning cycles will be carried out and, at the end of each one, its progressive number (xxxx) will appear on the display.	

### 6.1.4 PRINT CHART (not active with a colour print head)

This test **MUST** be carried out after replacing: the printer unit, motherboard, carriage, carriage motor or paper motor.

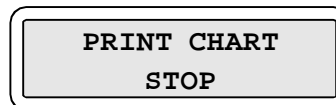
Setting	Display
a) The facsimile machine is in standby mode	



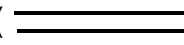

b) Get access to the system test menu and select the PRINT CHART option



c) Make sure that there is paper in the ASF and then press **START**: the test chart shown in fig. 6-4 is printed out .



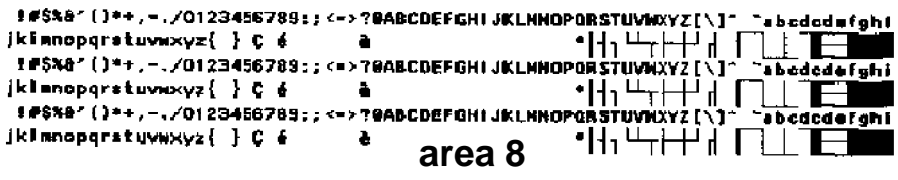
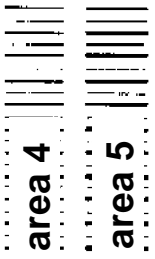
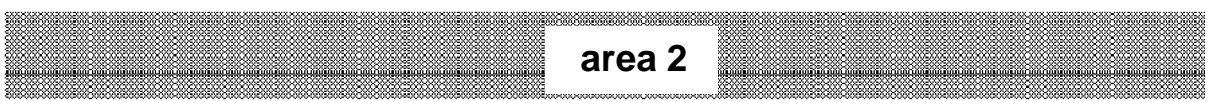
d) With reference to the figure, check that:

- lines 1, 10, 11 and 12 delimit the **printable area** on an A4-size sheet (about 208 x 290 mm)
- area 2 is used to evaluate that the **transport speed** of the print carriage is uniform: no shadings should result in the strip
- area 3 is used for checking **vertical alignment**; run the printer alignment test, if necessary, to modify the alignment parameters (see section 6.1.1)
- areas 4, 5 and 7 are used for checking that the **line feed mechanism is uniform**:
  - in area 4, groups of lines are printed close together but must never cross or overlap (  ); the groups alternate in lines corresponding to the central nozzle on the print head (number 25)
  - in area 5, groups of lines are printed one on top of another and there must be no space between them (  ); the groups alternate in lines corresponding to the central nozzle on the print head (number 25)
  - in area 7 dark grey and light grey patterns are printed forming a uniform strip, that is, without black or white lines distributed irregularly across it; if the lines appear at regular intervals along the strips, some of the nozzles are faulty

Faults found in areas 4, 5 and 7 indicate line feed errors

- four areas 6 are used for checking " **all black** " printing; check that there are no white lines present; if there are, some print nozzles may be blocked. In this case, run CLEANING (see section 6.1.3)
- area 8 is used for checking the printing of **ASCII characters**
- area 9 is used for checking printing with the nozzles spraying at **maximum frequency**: there must be no white or broken lines; if there are, run the nozzles test (see section 6.1.2).

line 1



BubbleJet Fax Print Chart



line 10


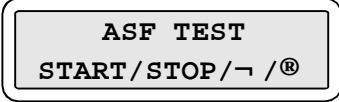


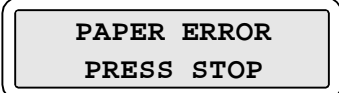
line 11

line 12

Fig. 6-4

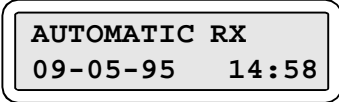

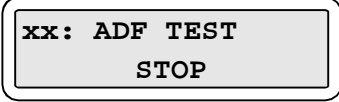
### 6.1.5 ASF TEST (not active with a colour print head)

This test **MUST** be carried out after replacing: the paper motor or the printer unit.

Setting	Display
a) The facsimile machine is in standby mode.	
b) Get access to the system test menu and select the ASF TEST option	
c) Place a blank sheet of paper in the ASF and then press <b>START</b> : the same line is printed on both top and bottom of sheet as in the case of the alignment test (fig. 6-2): 	
d) If the paper gets jammed, the message PAPER ERROR appears on the display.	

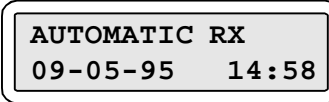

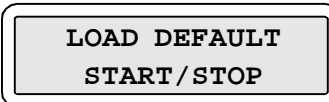
### 6.1.6 ADF TEST

This test **MUST** be carried out after replacing: the feeder rollers or the scanner unit.

Setting	Display
a) The facsimile machine is in standby mode	
b) Get access to the system test menu and select the ADF TEST option	
c) Place one or more sheets with text and pictures in the automatic document feeder and then press <b>START</b> : the documents are scanned one at a time and, at the end of the operation, a message appears indicating the number of documents scanned ( <b>xx</b> )	
d) If you want to repeat the test, insert more sheets in the feeder and press <b>START</b> .	

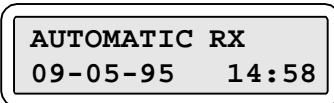
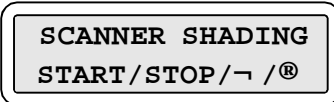
## 6.1.7 LOAD DEFAULT

This procedure is used for loading the default values of the service switches for the current country version of the facsimile machine.

Setting	Display
a) The facsimile machine is in standby mode	
b) Get access to the system test menu and select the LOAD DEFAULT option	
c) Press <b>START</b>	
d) Press <b>START</b> once again: the default values of the U.K. service switches are automatically set in place of the current ones, <b>clearing the static RAM</b> and thus deleting all data (reports) set by the user.	

## 6.1.8 SCANNER SHADING

This test **MUST** be carried out after replacing: the scanner unit, motherboard or CCD board. It must also be carried out after making the CCD adjustment (see section 6.3).

Setting	Display
a) The facsimile machine is in standby mode	
b) Get access to the system test menu and select the SCANNER SHADING option	
c) Open the console and remove the ejector roller (see section 7.2.11)	
d) Place a blank sheet (folded in two) onto the glass of the optical reader so that it covers the glass entirely but not the document sensor (see section 2.2.2).	

## Setting

## Display

e) Reassemble the roller and close the console.

f) Press **START**

SCANNER SHADING  
START/STOP

g) Press **START** once again: the LED array lights up to automatically check the white level, and the result is saved to ensure correct CCD operation

SCANNER SHADING  
STOP

### **Warning:**

Should the blank sheet not be correctly positioned, a beep is generated as you press **START**.

h) Press **STOP** to switch off the LED array.

## 6.1.9 CARRIAGE TEST

This test **MUST** be carried out after replacing: the carriage, carriage motor or printer unit.

## Setting

## Display

a) The facsimile machine is in standby mode

AUTOMATIC RX  
09-05-95 14:58

b) Get access to the system test menu and select the CARRIAGE TEST option

CARRIAGE TEST  
START/STOP / ⏪ / Ⓜ

c) Press **START**: the carriage starts moving from right to left and gradually increases its field of movement until it reaches the left-hand side of the machine, and then it repeats this procedure.

CARRIAGE TEST  
STOP

## 6.2 CHECKS AND ADJUSTMENTS

### 6.2.1 Checking the direct voltages

- 1) Remove the power supply/NCU assembly (see section 7.2.3) without disconnecting it from the motherboard
- 2) Measure the direct voltages at connector J2 on the power supply board.

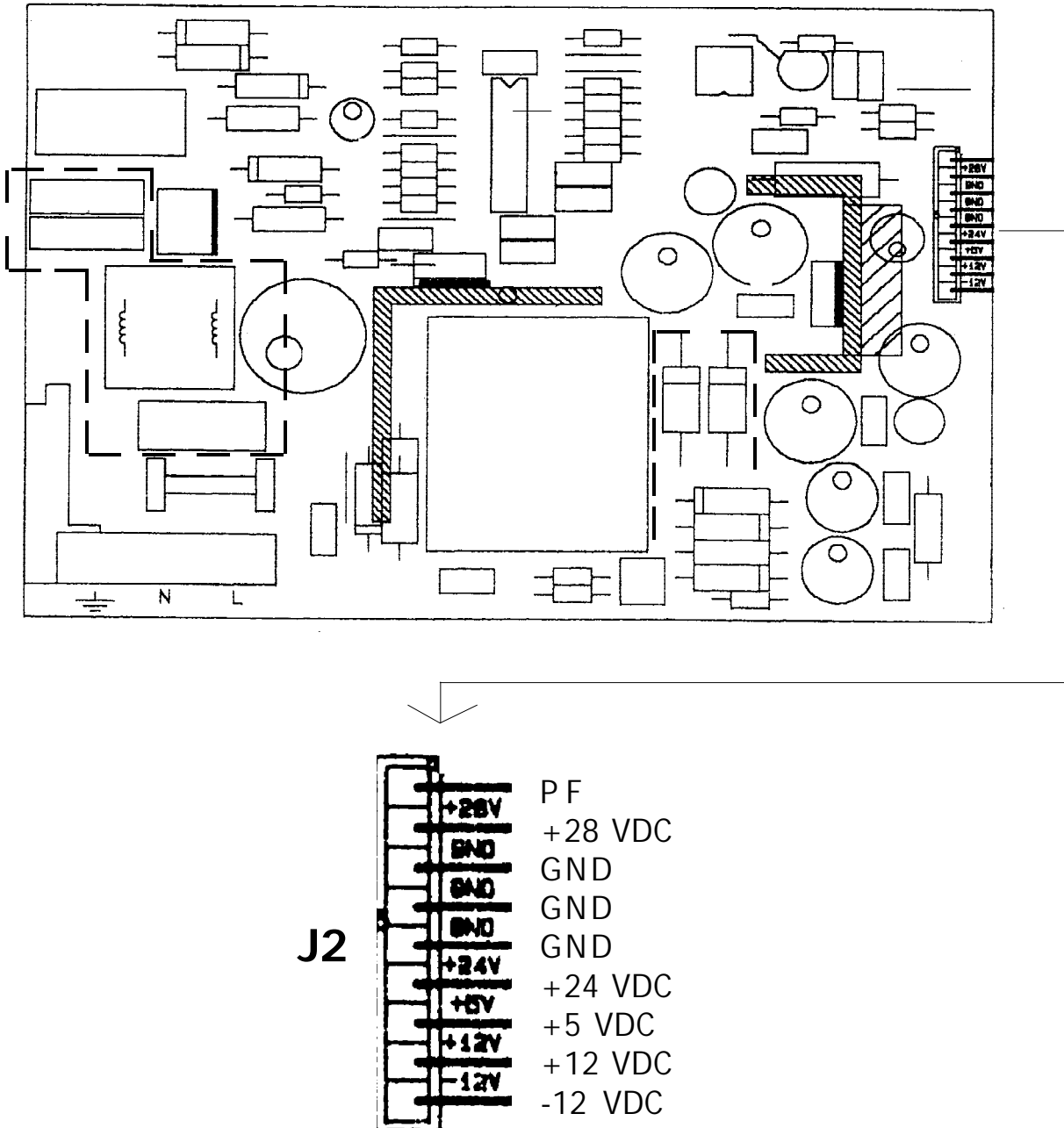
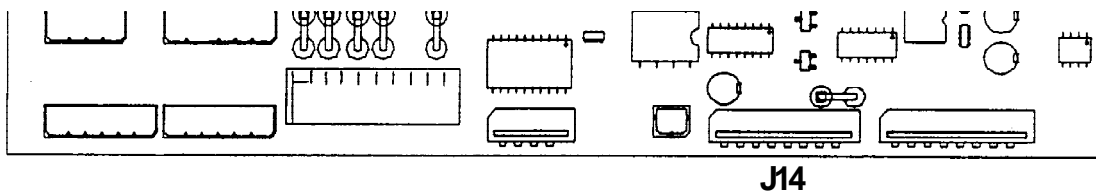


Fig. 6-5

## 6.3 ADJUSTING THE CCD

This adjustment **MUST** be performed, *exclusively in a laboratory*, after replacing the CCD board, and requires the following equipment:

1. a special jig (order code 98870 H)
2. a flat cable like the one that connects the CCD board to the motherboard
3. a plate with test points, which may be prepared at the laboratory, bearing in mind that the test point signals must correspond to the following pins of connector **J14** on the motherboard: RS = 8, SH = 13, VIDEO = 10, GND = 4-9-11



4. an oscilloscope with a memory to function as an "event counter"
5. a sample facsimile machine of the same class as the machine to be repaired.

### 6.3.1 Preparing for the CCD Adjustment

Before proceeding to adjust the CCD, the sample facsimile machine must be prepared and connected to the scanner unit on which the CCD board has been replaced.

- 1) Disconnect the CCD flat cable from connector J8 on the motherboard and plug in one end of the additional flat cable in its place (see figure 6-6)
- 2) Plug the other end of the additional flat cable into one connector of the test point plate and then the replaced CCD board flat cable into the remaining connector on the plate (see figure 6-6)

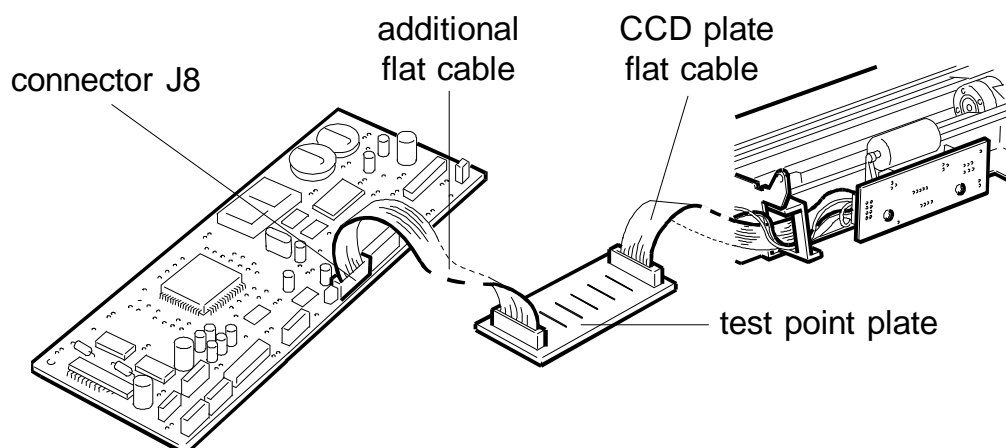
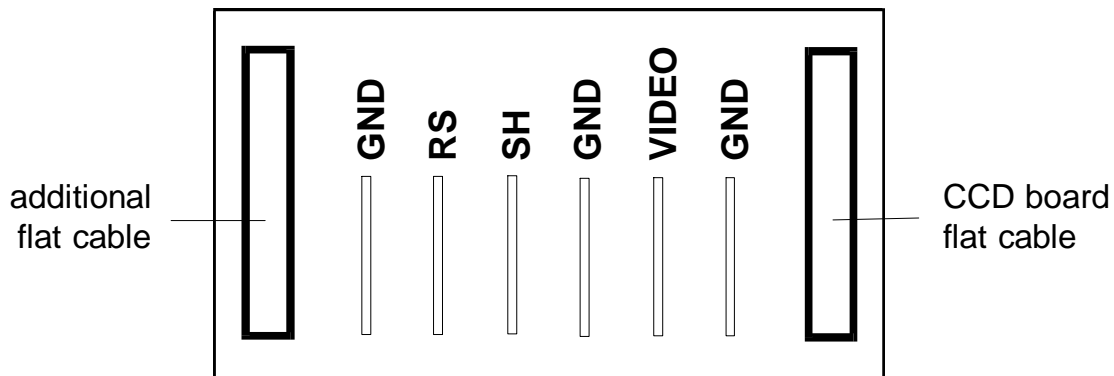


Fig. 6-6

- 3) Connect the probe of channel **CH1** of the oscilloscope to the test point "**VIDEO**", the probe of channel **CH2** to test point "**RS**", the ground wires of the probes to test points "**GND**" and the probe of the *external trigger* to test point "**SH**" (see figure 6-7)



**Fig. 6-7**

- 4) Set the oscilloscope as follows:

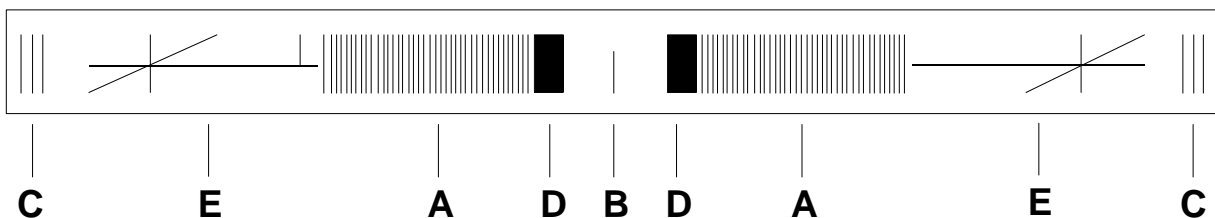
- CH1 = 1V/ division                      - CH2 = 2V/ division

- 5) Power on the facsimile machine and then, with the **START** key held down, press the \* key twice in quick succession to gain direct access to the **SYSTEM TEST** utilities (see section 6.1)
- 6) Press the < key to select **SCANNER SHADING** and press the **START** key: the LED array will light up so that the **CCD** adjustment can be made.

### 6.3.2 Checking the Alignment of the CCD Board

- 1) Tilt the console forward, remove the document ejector roller (see section 7.2.11) and insert the jig in its place with its printed side facing the optical reader glass, and then close the console again.

The jig consists of several different areas (see figure 6-8)

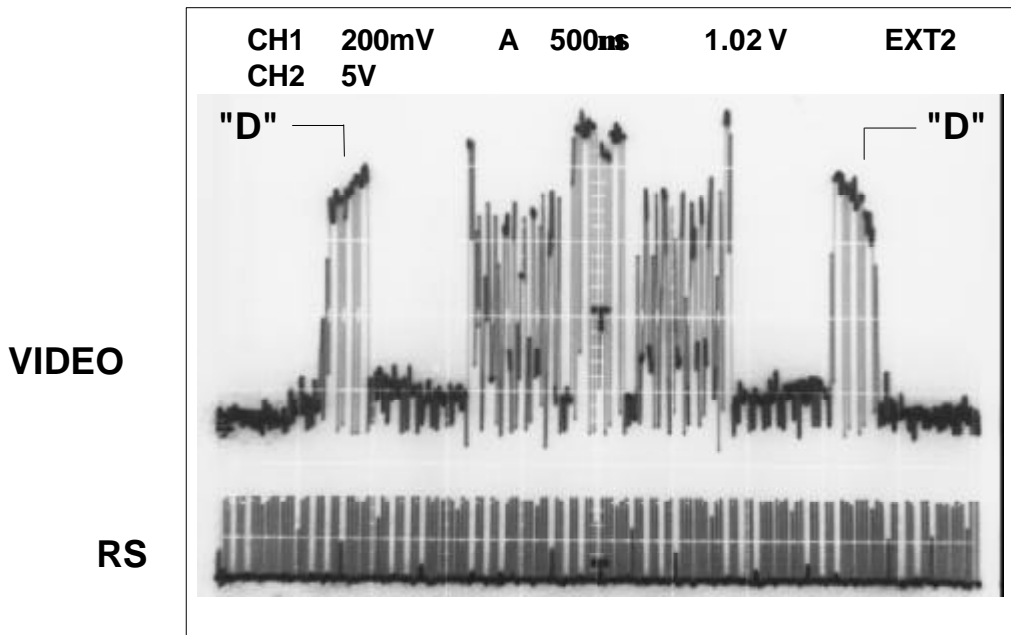


**Fig. 6-8**



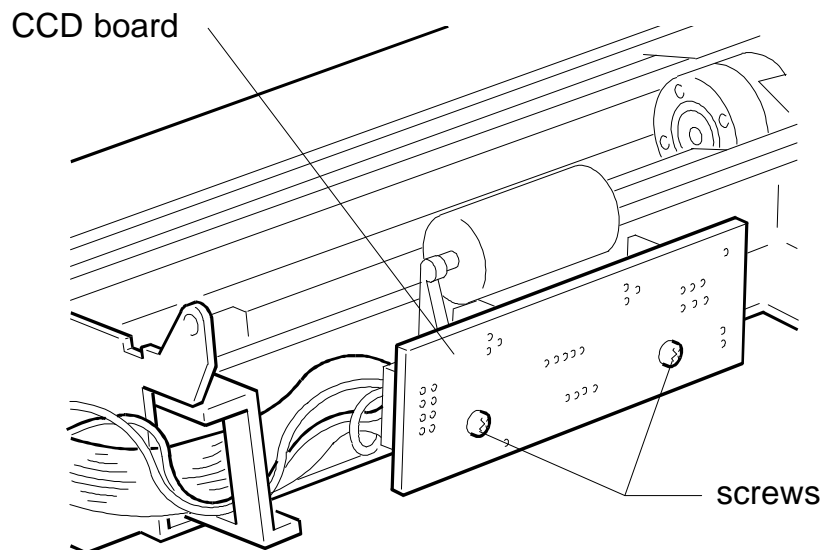
- area "A", for testing lens focussing
- area "B", for testing that the document and the CCD are centred
- area "C", for checking that the edges of the document are scanned
- area "D", for testing the black level
- area "E", for testing the scanning position

2) Check that the VIDEO signal moves parallel to the horizontal lines on the screen and that the lines in area "D" are symmetrical and parallel to the ground line (see figure 6-9)



**Fig. 6-9**

3) If they do not, loosen the screws on the CCD board, turn the board to the desired position and tighten the screws (see figure 6-10)



**Fig. 6-10**

### 6.3.3 Checking the Lens Focus

- 1) Check that the VIDEO signal for areas "A" on the jig is at its maximum amplitude (see figure 6-11)

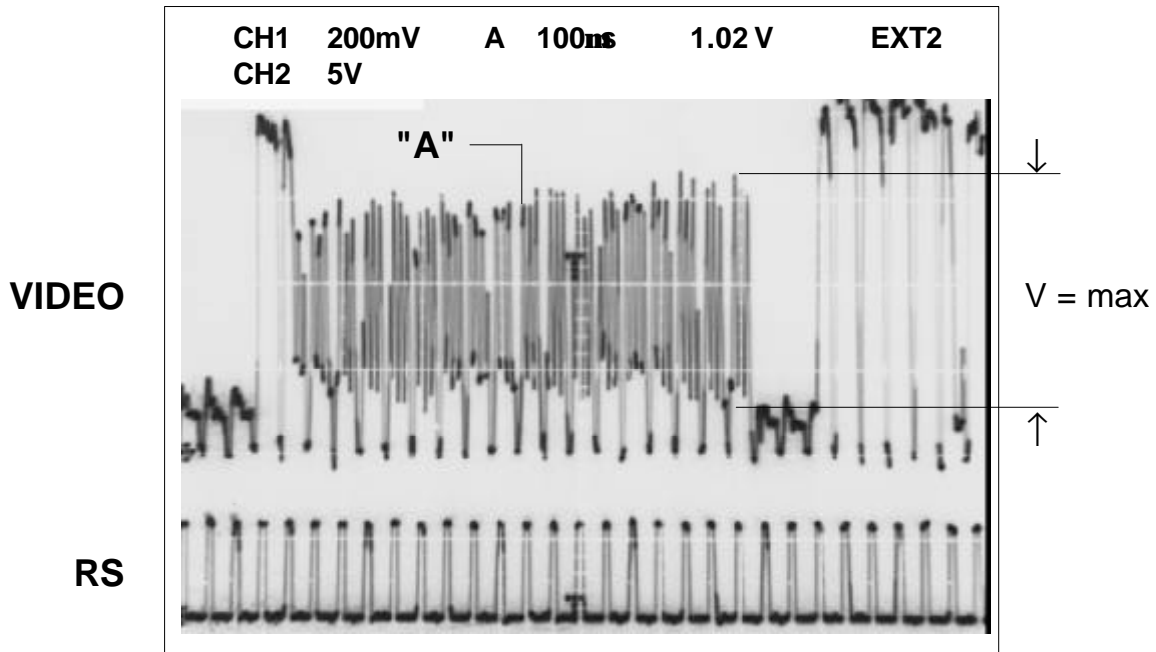


Fig. 6-11

- 2) If it is not, loosen the two screws and move the lens to the desired position (see figure 6-12); then fix the screws in position with a drop of glue.

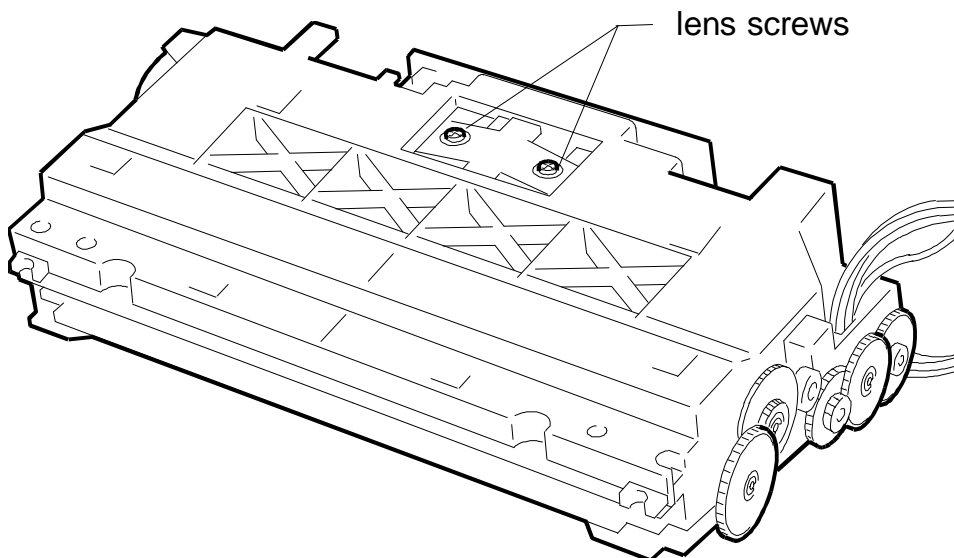


Fig. 6-12

### 6.3.4 Checking That the Document and the CCD Are Centred

- 1) Set the EVENT COUNTER of the oscilloscope to 1037
- 2) Check that the VIDEO signal corresponding to area "B" of the jig has a negative peak aligned to the T marks (a deviation of  $\pm 5$  events is acceptable) (see figure 6-13)

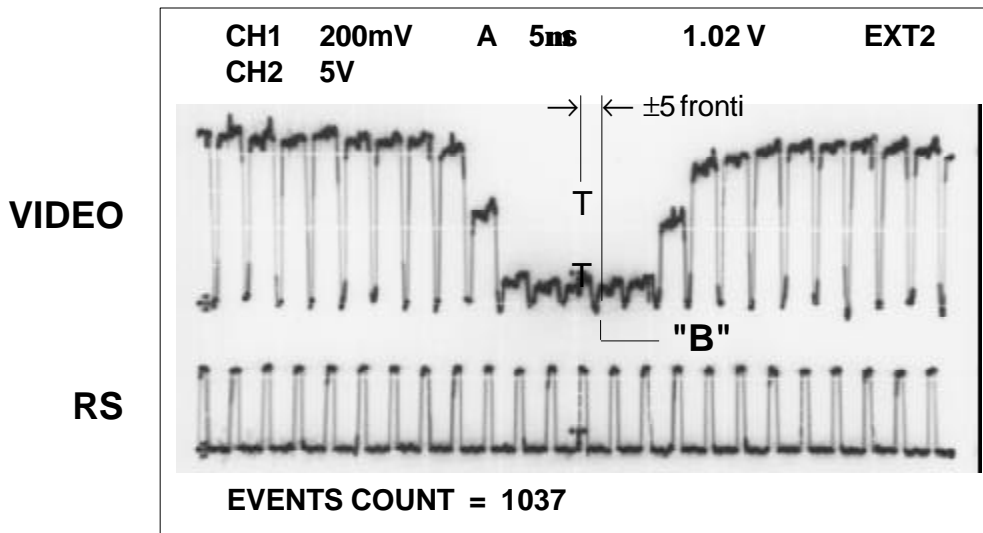


Fig. 6-13

- 3) If it has not, move the plate sideways to the desired position.
- 4) Check that the VIDEO signal for areas "C" of the jig (on right and left) has three negative peaks corresponding to the three lines in the same area (see figure 6-14), and then tighten the screws.

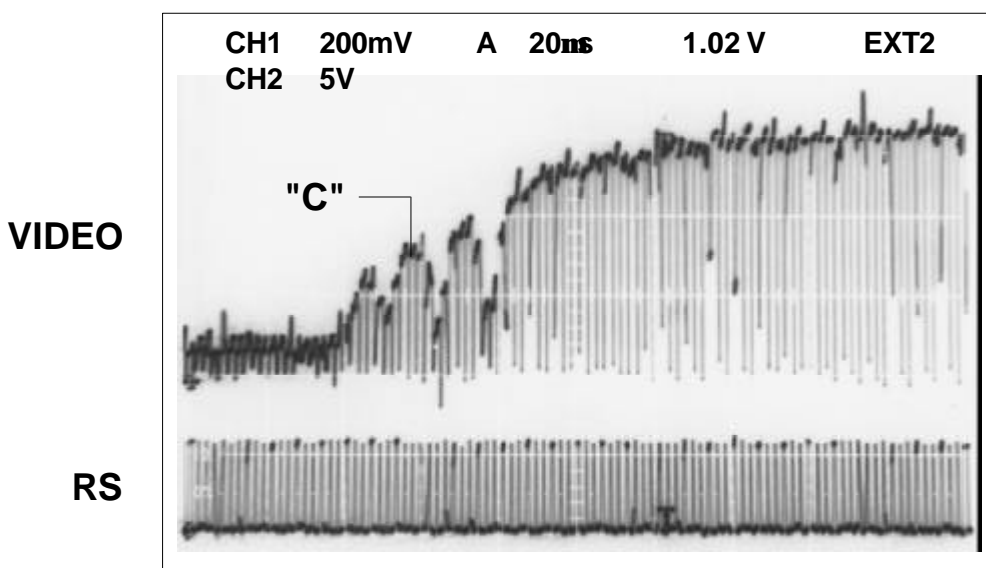


Fig. 6-14

- 5) Having adjusted the CCD, make the SCANNER SHADING (see section 6.1.8).

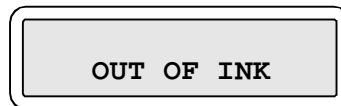
# 7. MAINTENANCE AND REPLACEMENT PROCEDURES

## 7.1 MAINTENANCE

The facsimile machine's maintenance includes **periodic preventive procedures** (such as optical unit cleaning), and **action to be taken following a message** on the display (such as the ink out message): the procedures are normally carried out by the user so they will be described in detail in the User Guide. Here only a brief description is provided.

### 7.1.1 OUT OF INK Message

The facsimile machine has a built-in counter (\*) for keeping track of ink consumption, so as to provide an ink out message at the right time. When the ink present in the cartridge runs out, the display shows the following message:



to prompt the operator to:

- replace the **ink cartridge**, if the print head is of the **rechargeable** type
- replace the **entire print head**, if it is of the **disposable** type.

If a rechargeable print head is used, the ink cartridge can be replaced several times. When a deterioration in the printing quality is observed, after several replacements, this means that the entire print head is to be replaced.

While replacing the **cartridge only**, but not the entire print head, a little ink may be ejected, to prevent the printing area from getting dirty, when the out of ink message appears, **a sheet of paper is automatically inserted** under the print carriage.

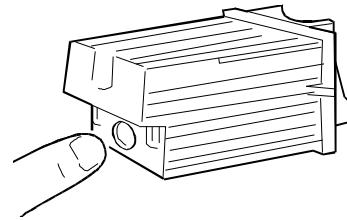
---

(\*) Two counters on the LinkFax model, one for the monochrome print head and another for the colour print head.

## 7.1.2 Replacing the rechargeable Ink Cartridge

1. Tilt the printer cover.
2. Remove the used cartridge, **without removing the print head**, by pressing the catch.
3. Remove the new cartridge from its sealed packing and peel the protective film off the ink supply hole.

**WARNING**  
**Do not touch the inked area!**



4. Insert the cartridge in its housing immediately and press it in until the catch clicks into place to indicate that the cartridge is correctly inserted.
5. Close the printer cover: if the **head cleaning** feature is enabled (bit 2 of software parameter SW09 =1, see section 4.1), the facsimile machine automatically starts the **nozzle cleaning and testing procedure** (see section 3.1.4, step 7). If it is not, the sheet of paper is unloaded.

**Warning:** Whenever you replace a rechargeable colour cartridge on the LinkFax model before the out-of-ink message is displayed, it is necessary to manually clear the internal counter in order for the ink level monitored by the counter to be consistent with the actual level contained in the cartridge:

- Press 3 times the **FUNCTION** key and then the **START** key to make the following message displayed:

NEW PRINT HEAD?	
1=YES	0=NO

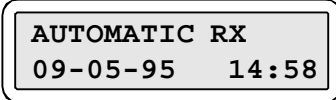


- Enter **1** and press the **START** key: the nozzles cleaning and checking procedure is automatically started while the counter is cleared.

### 7.1.3 Replacing the Print Head

See section 3.1.4. (starting from step 4).

### 7.1.4 Cleaning the Print Head

If you notice a deterioration in the printing quality, first run the nozzles test (see section 6.1.2) to assess whether it is necessary to perform the CLEAN HEAD operation, which consists of a cleaning cycle of the nozzles.

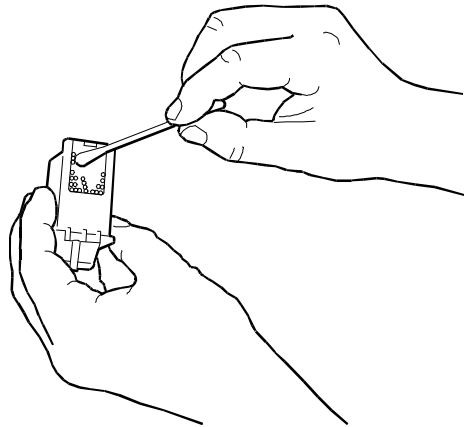
Setting	Display
1) The facsimile machine is in stand-by mode	
2) Access the main menu and select the HEAD MAINTENANCE submenu of the FAX SETUP menu	
3) Press <b>START</b> twice to start procedure.	

## 7.1.5 Cleaning the Electrical Contacts

If a deterioration of the print quality is observed, it may be necessary to clean the electrical contacts on the print head

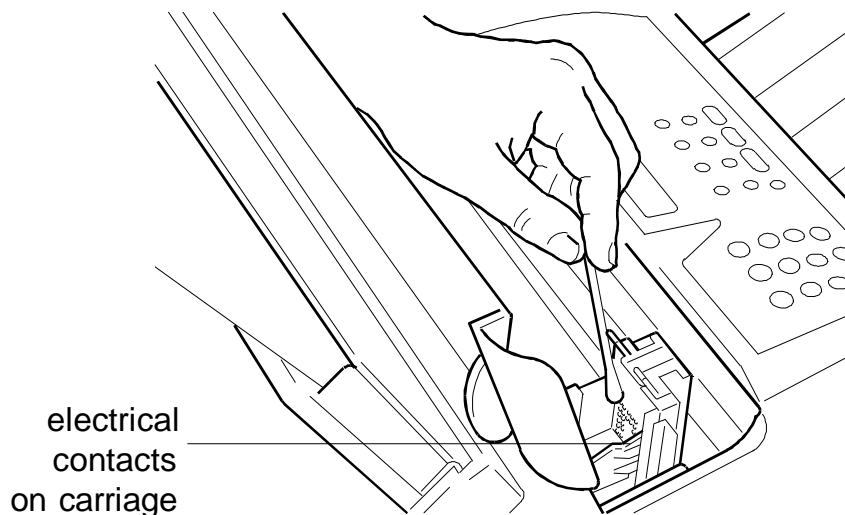
- 1) Unplug the power cable from the mains socket and tilt the printer cover
- 2) Remove the print head and clean the electrical contacts using a dry cotton swab (see figure 7-1)

**Warning: Do not touch the printing nib.**



**Fig. 7-1**

- 3) Clean also the electrical contacts on the print carriage using a dry soft cloth (see figure 7-2).

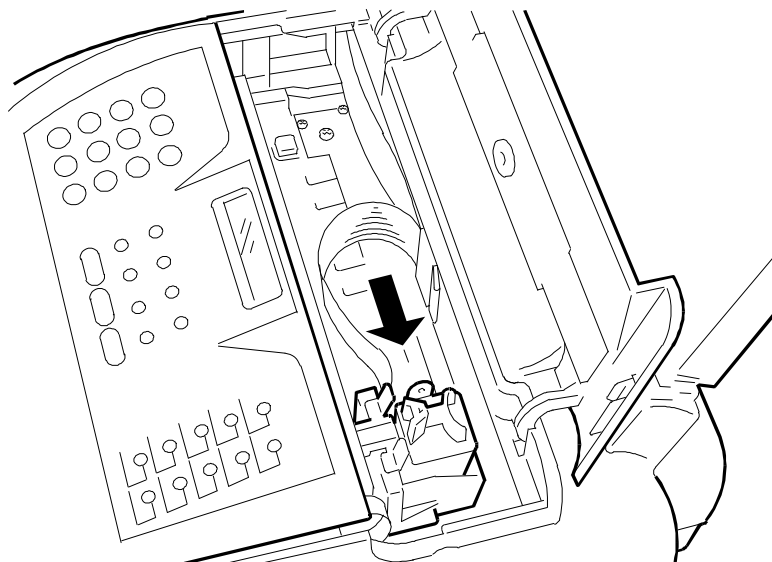


**Fig. 7-2**

- 4) After reinserting the print head, close the printer cover.

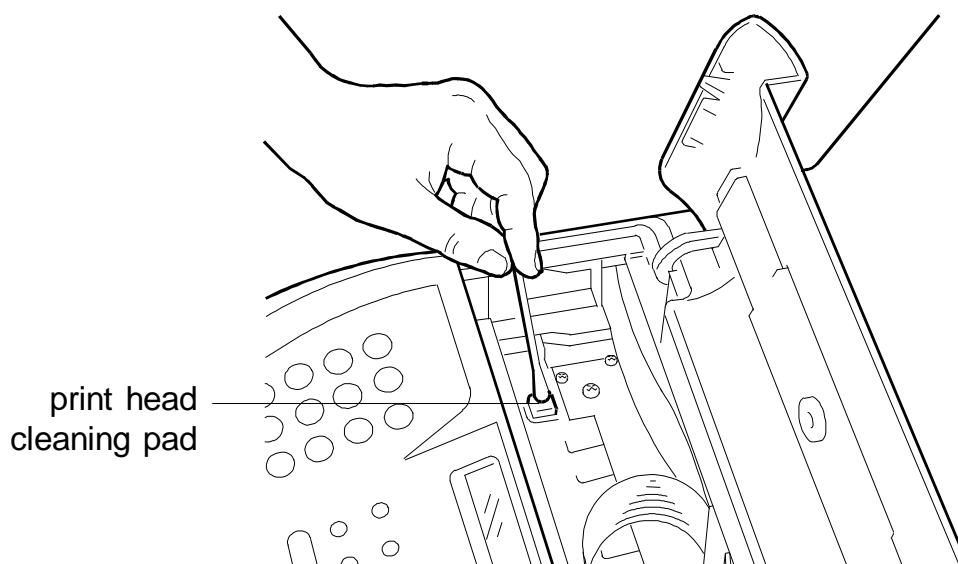
## 7.1.6 Cleaning the Print Head Cleaning Pad

- 1) Unplug the power cable from the mains socket, then tilt the printer cover.
- 2) Remove the print head and move the carriage to the right-hand side (see figure 7-3)



**Fig. 7-3**

- 3) Clean the print head cleaning pad using a dry cotton swab (see figure 7-4). Close the printer cover.



**Fig. 7-4**

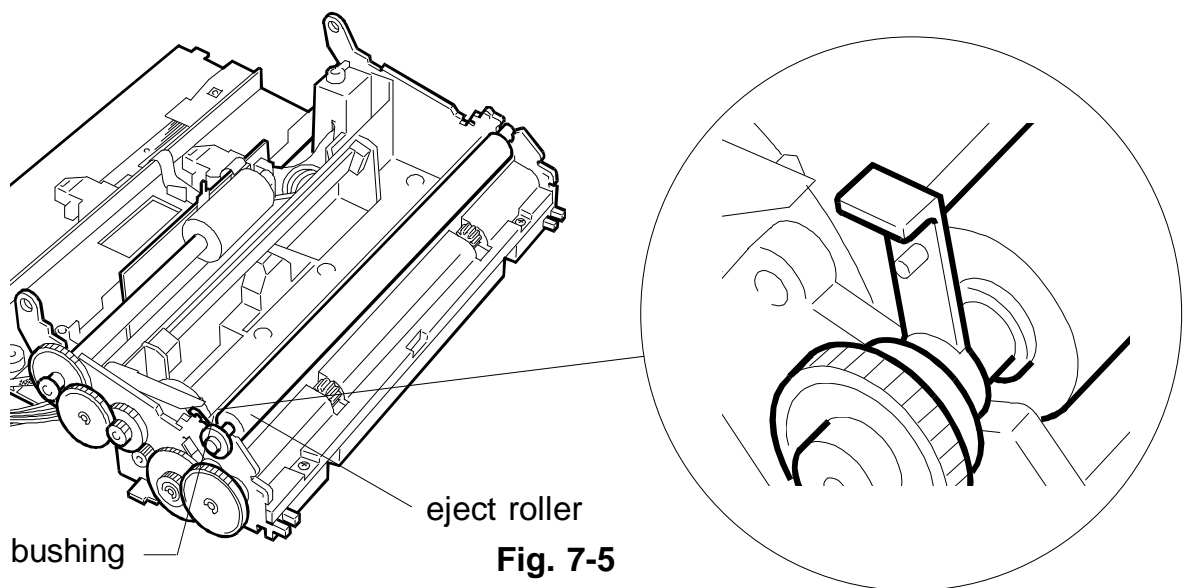


## 7.1.7 Cleaning the Optical Unit

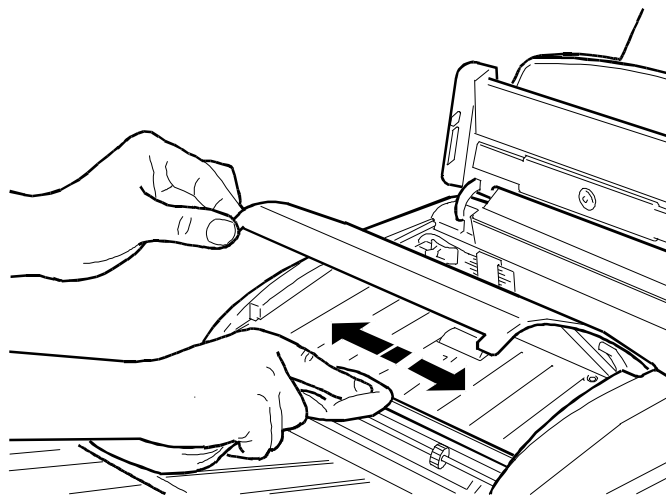
Dust may accumulate on the glass, feeder rollers and mirrors inside the optical unit and cause document scanning problems; to avoid this happening, clean these components every now and again as described below.

### 7.1.7.1 Cleaning the Glass and Feeder Rollers

- 1) Unplug the power cable from the mains socket and tilt the printer cover
- 2) Release the left bushing on the eject roller by turning it towards the front and slide the roller out from the right-hand side (fig. 7-5)

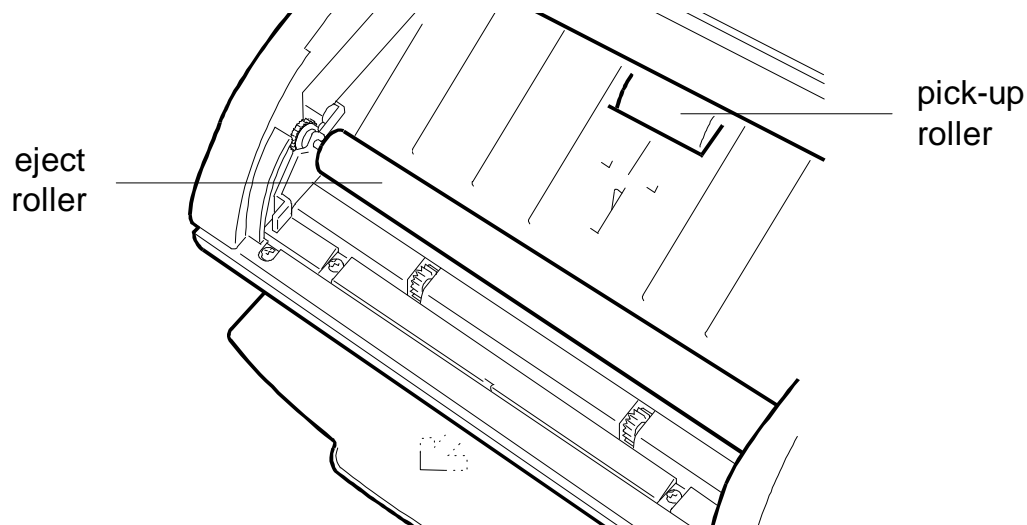


- 3) Clean the eject roller and the glass of the optical unit using a cloth dampened with a specific glass cleaning product, and then carefully wipe dry (see figure 7-6)



**Fig. 7-6**

- 4) Clean the document feed rollers with a cloth soaked in a neutral detergent (see figure 7-7), reassemble the ejector roller and then close the printer cover.

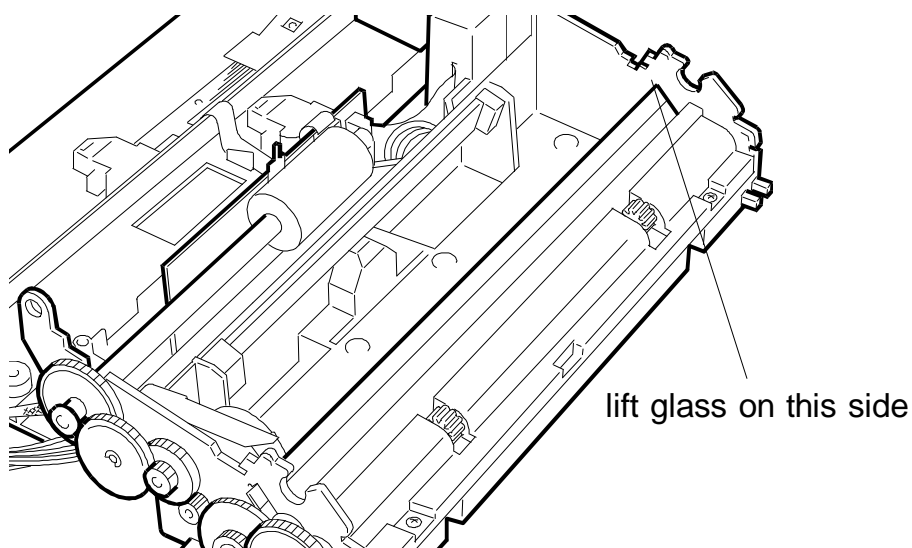


**Fig. 7-7**

### **7.1.7.2 Cleaning the Mirrors**

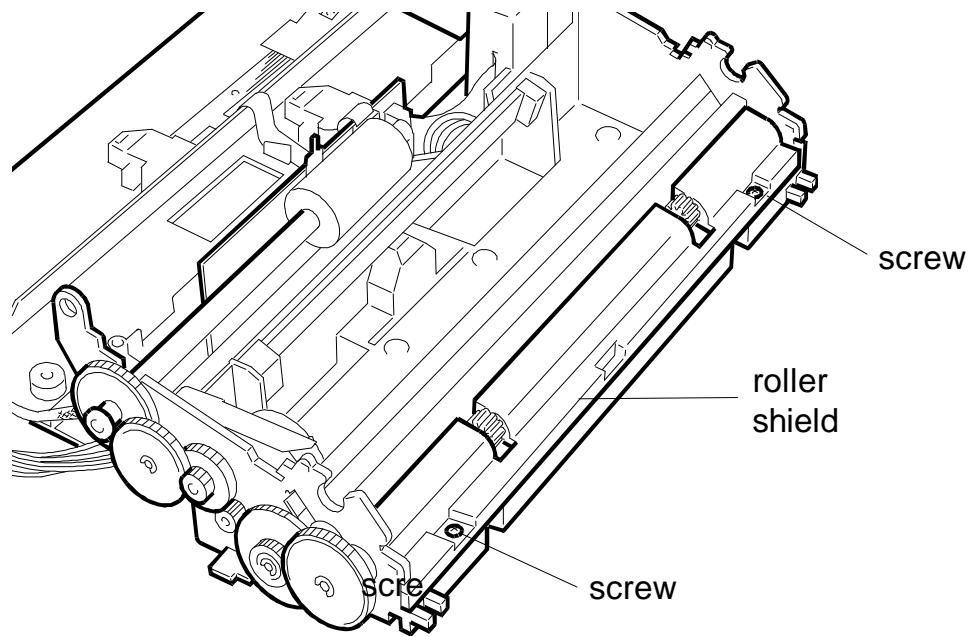
This procedure should only be carried out if, when copying a blank sheet, vertical black lines appear on the copy.

- 1) Remove the operator console (see section 7.2.6)
- 2) Remove the scanning plate (see section 7.2.10)
- 3) Remove the document ejector roller (see section 7.1.7.1)
- 4) Lift the right-hand side of the glass and slide it out from the left (fig. 7-8)



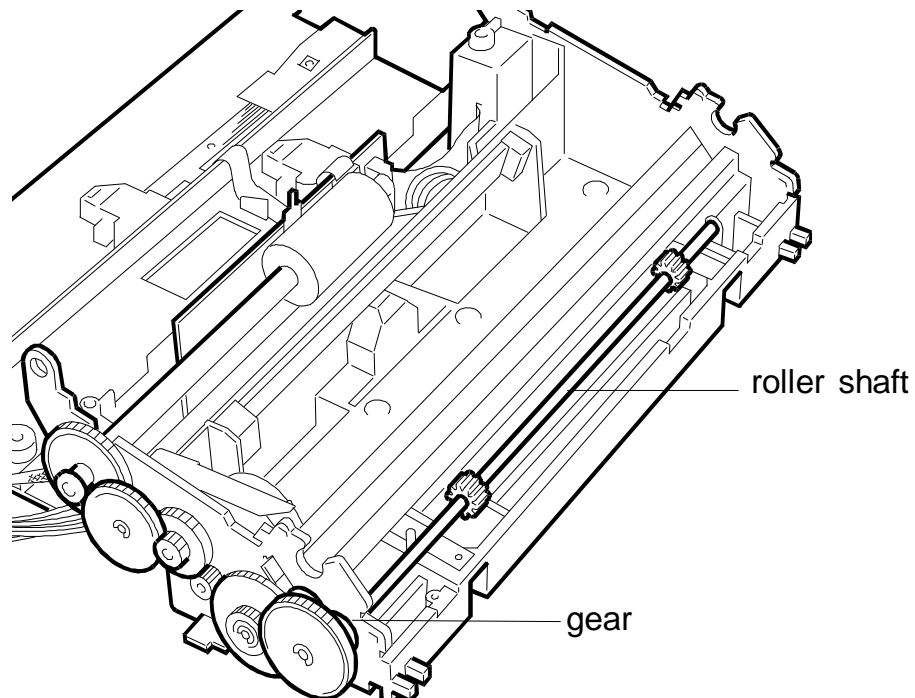
**Fig. 7-8**

5) Loosen the two screws and remove the roller shield (see fig. 7-9)



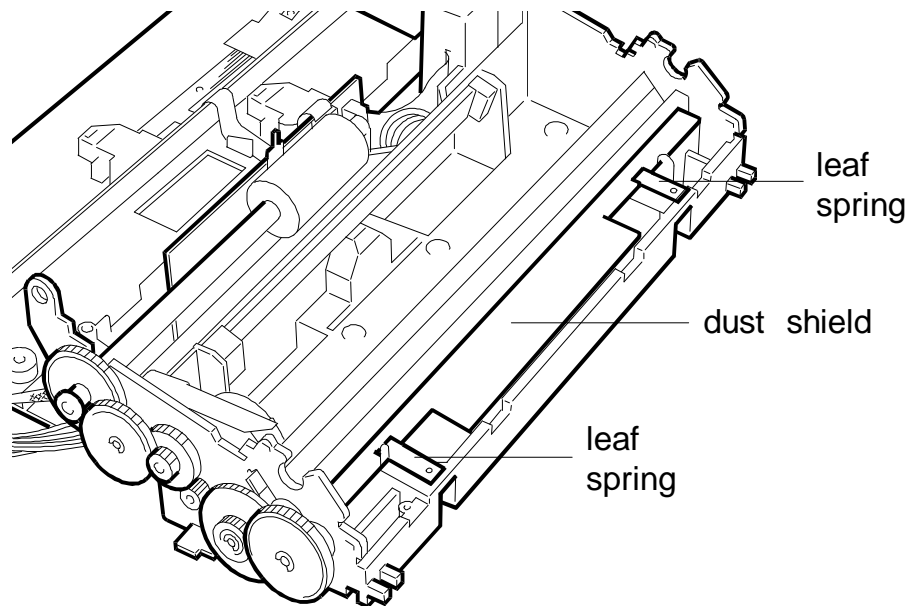
**Fig. 7-9**

6) Slide out the roller shaft and remove the left gear (see fig. 7-10)



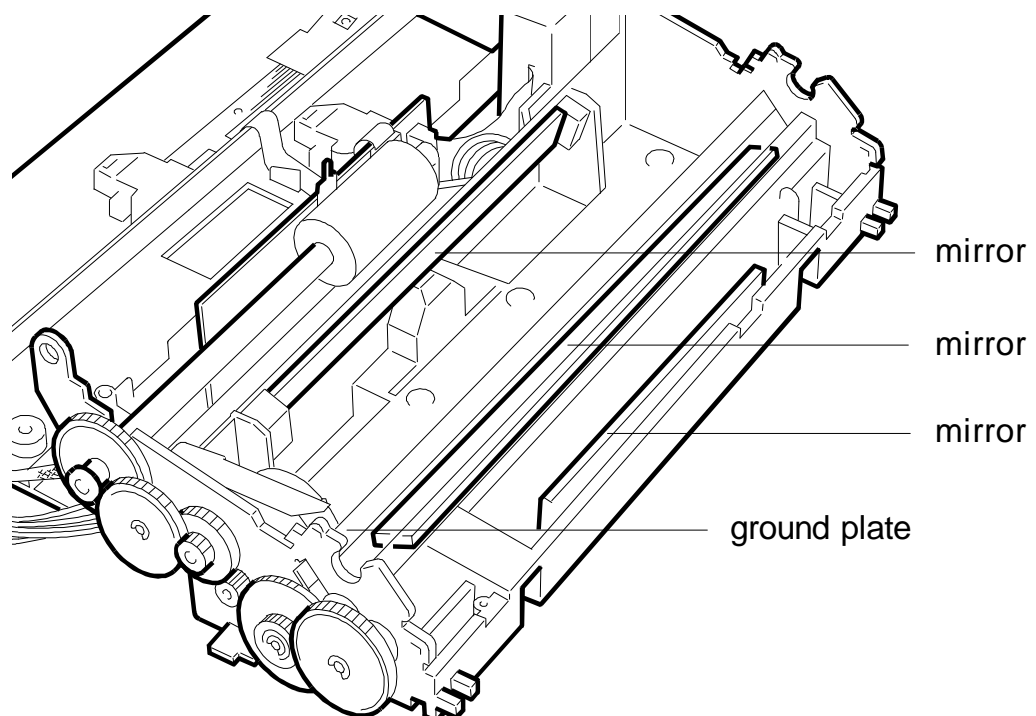
**Fig. 7-10**

7) Slide out the dust shield and remove the two leaf springs (see fig. 7-11 )



**Fig. 7-11**

8) Clean the three mirrors using a dry cotton swab (see fig. 7-12).



**Fig. 7-12**

**Warning:** during reassembly, make sure that the left ground plate is positioned under the glass (see fig. 7-12).

## 7.2 DISASSEMBLY AND REPLACEMENT PROCEDURES

This section describes how to disassemble and replace the main units of the facsimile machine.

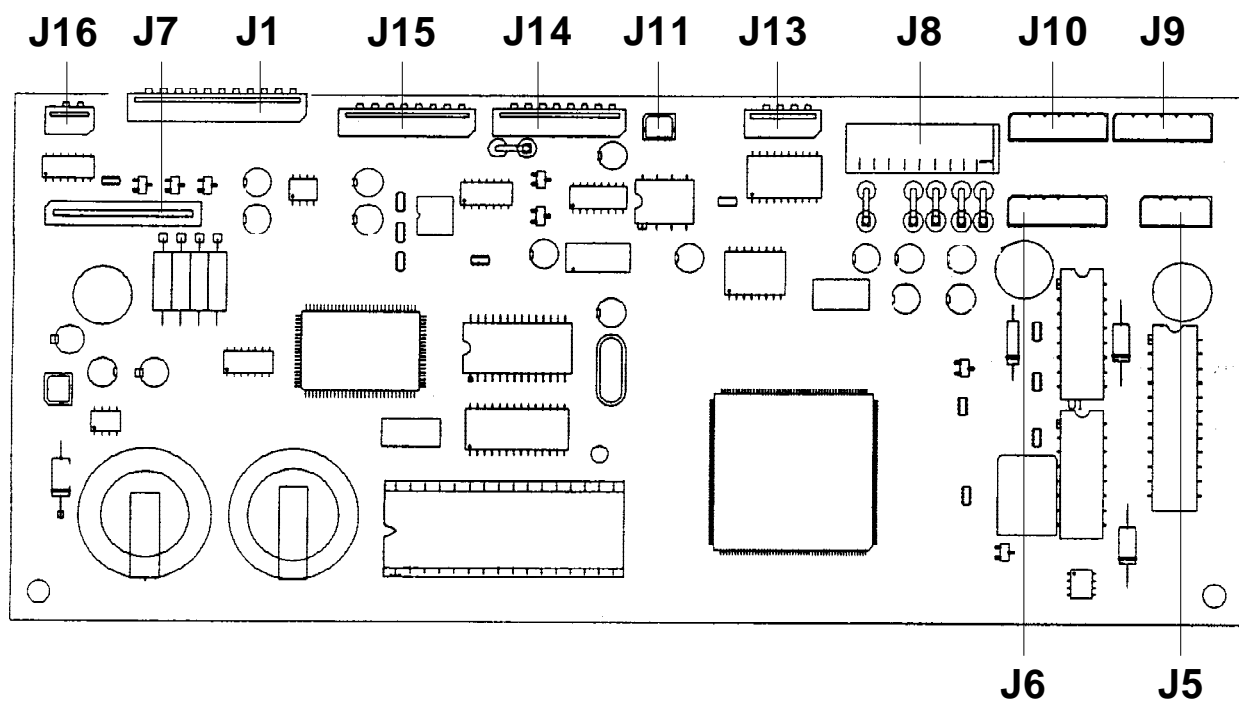
**WARNING:** Should a procedure require *one or more connectors to be unplugged from the motherboard*, we recommend the following:

- 1) **before starting the procedure**, print all configuration parameters (both user-level and service-level) and the user's telephone list
- 2) **upon completion of the procedure**, restore the facsimile as referenced in paragraph 7.2.16.

Before starting to disassemble the facsimile machine, unplug the power cable from the wall outlet and the telephone line.

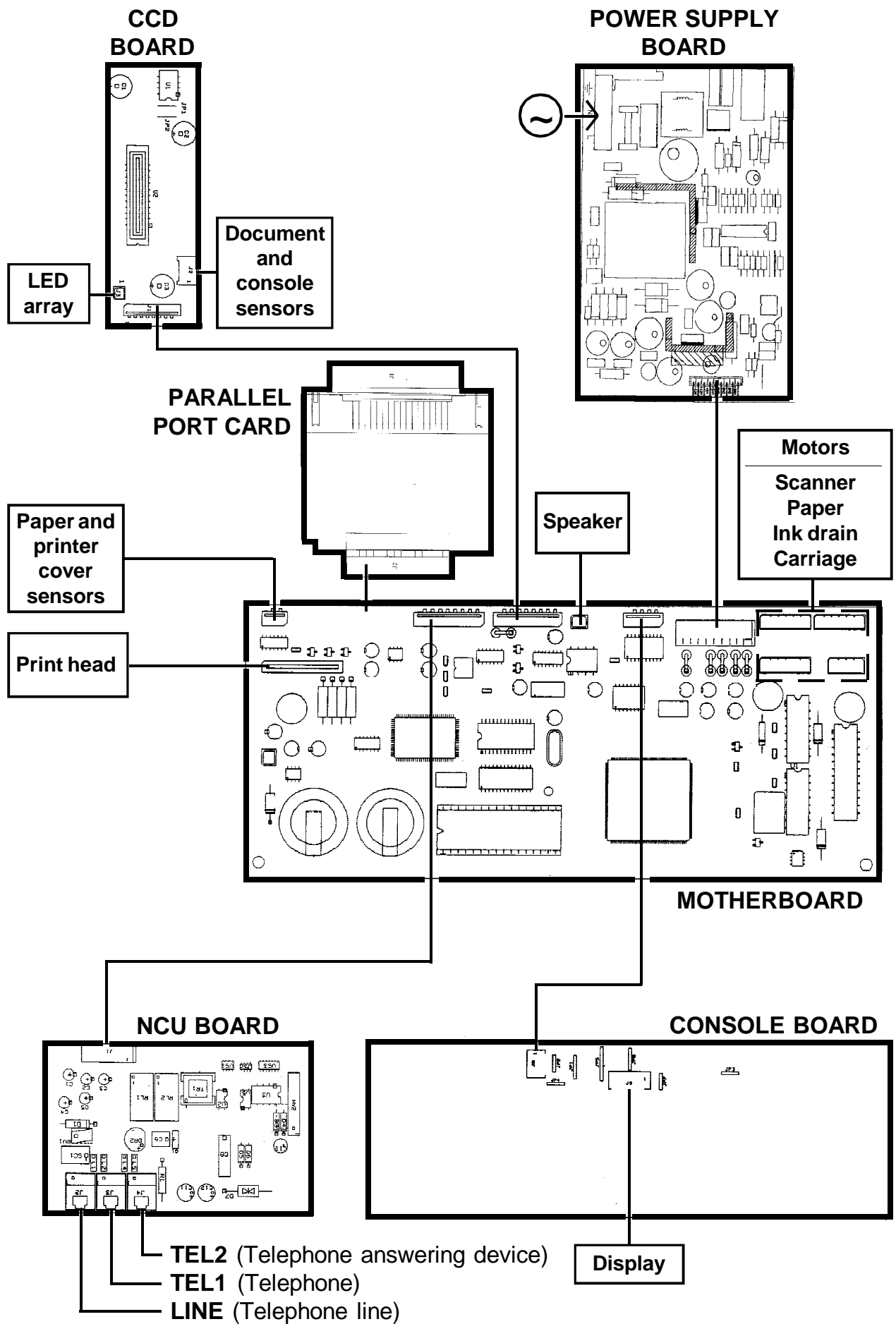
### 7.2.1 Wirings

This section illustrates the connectors on the motherboard and their connection to the facsimile machine units, so as to facilitate the reassembly of replaced units.



**Fig. 7.13 Locating the connectors on the motherboard**

<b>J1</b>	Parallel port card	<b>J10</b>	Scanner motor
<b>J5</b>	Carriage motor	<b>J11</b>	Speaker
<b>J6</b>	Paper motor	<b>J13</b>	Console
<b>J7</b>	Print head	<b>J14</b>	CCD board
<b>J8</b>	Power supply board	<b>J15</b>	NCU board
<b>J9</b>	Ink drain motor	<b>J16</b>	Paper and printer cover sensors



**Fig. 7.14 Wirings diagram**

## 7.2.2 Removing the Casing

- 1) Remove the document tray and the automatic sheet feeder.
- 2) Tilt the operator console, remove the two screws securing the front part of the casing (see fig. 7-15) and pull this part of the casing upwards.

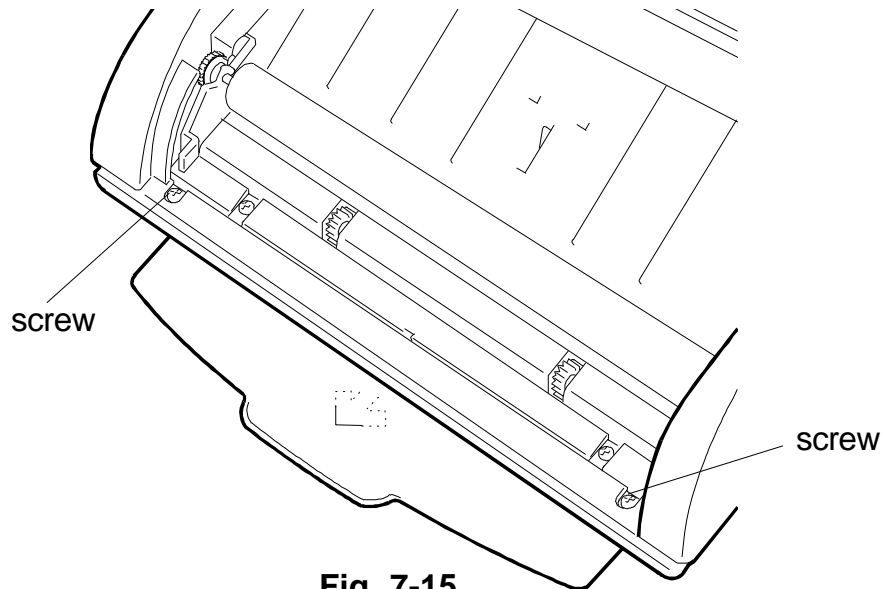


Fig. 7-15

**Warning:** during reassembly, make sure that the tabs on the rear of the casing are correctly inserted in the slots on the base (see fig. 7-16) and that the flat cables running along the sides of the base are not bent.

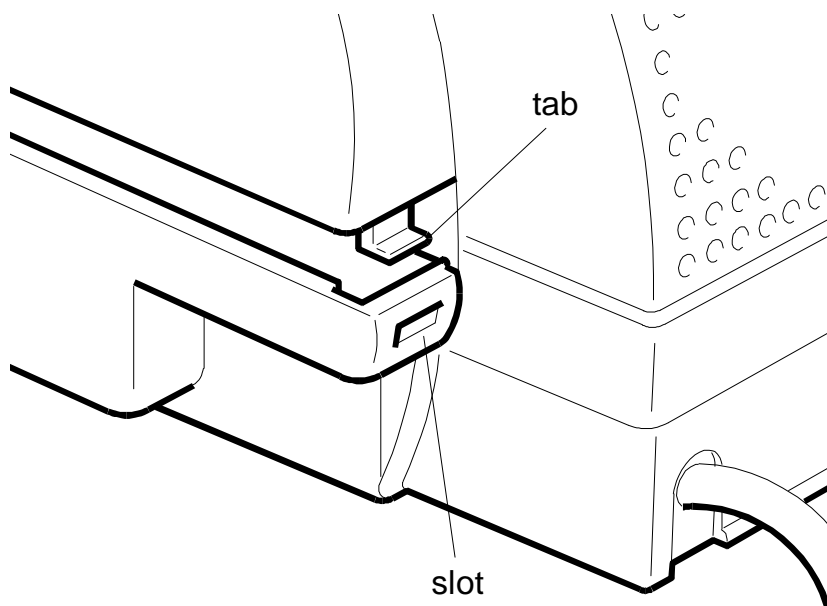


Fig. 7-16

### 7.2.3 Remove the Power Supply/NCU Assembly

- 1) Remove the automatic sheet feeder
- 2) Unscrew the two screws (see fig. 7-17) and remove the cover

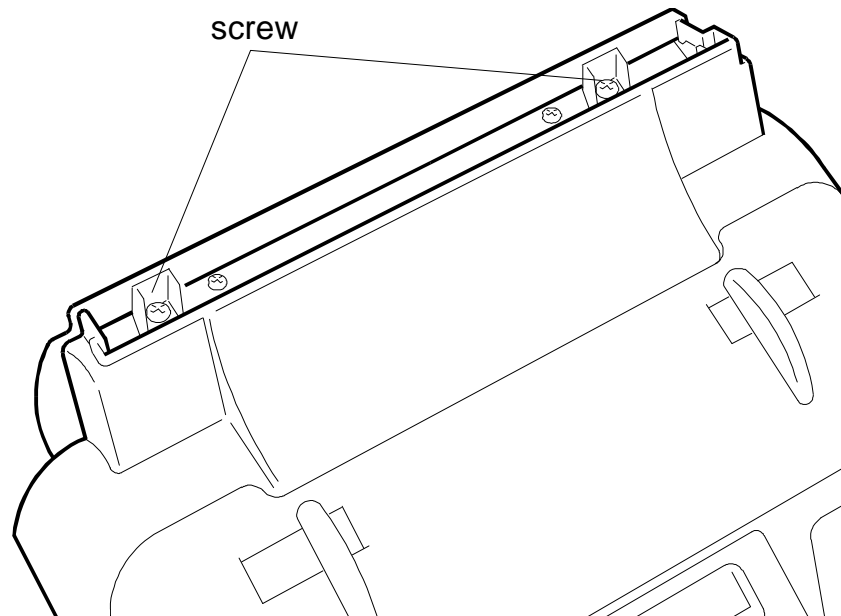


Fig. 7-17

- 3) Remove the two screws securing the parallel port, the four upper screws that secure the printer unit and the two lateral screws that fix the unit to the base (see fig. 7-18)

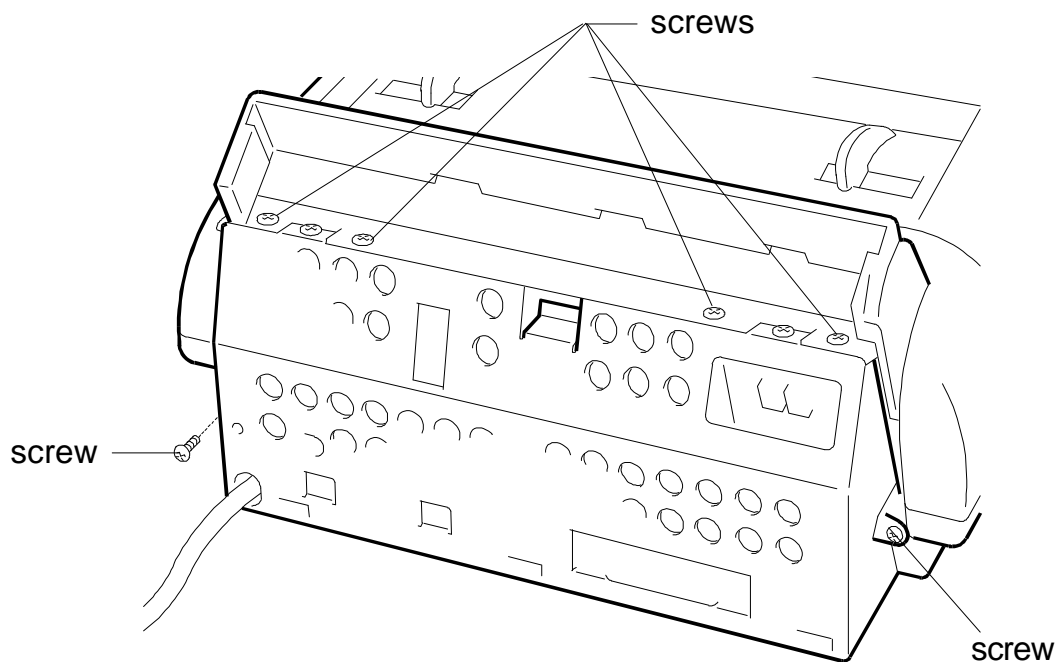
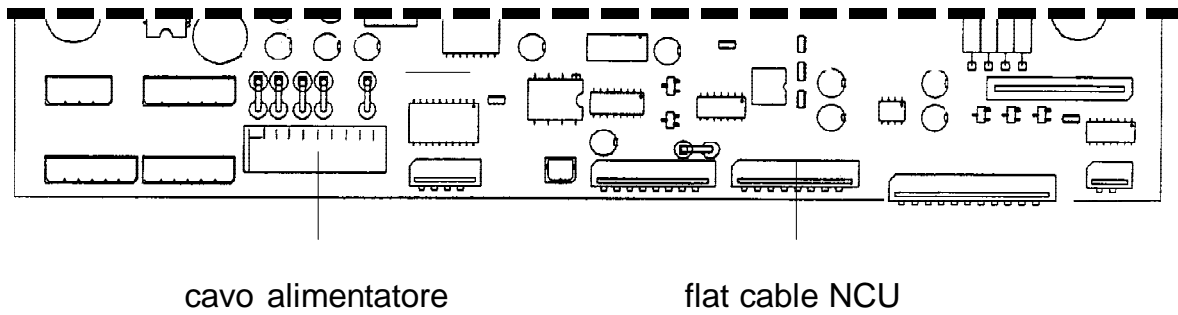


Fig. 7-18



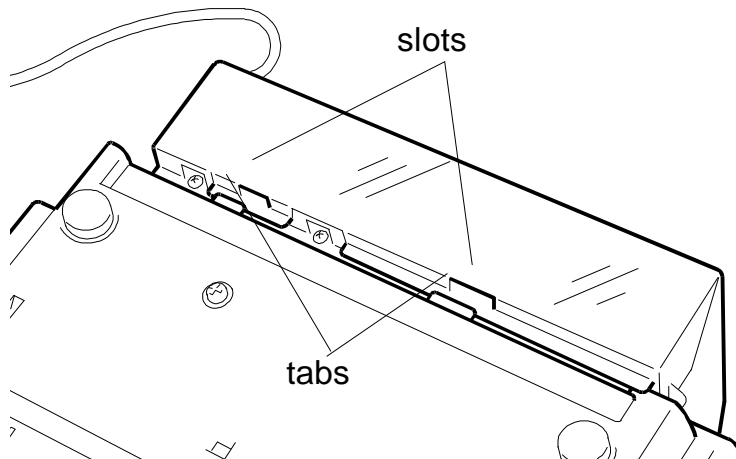
- 4) Unplug the NCU board flat cable and the power supply cable from the motherboard (see fig. 7-19), then remove the assembly



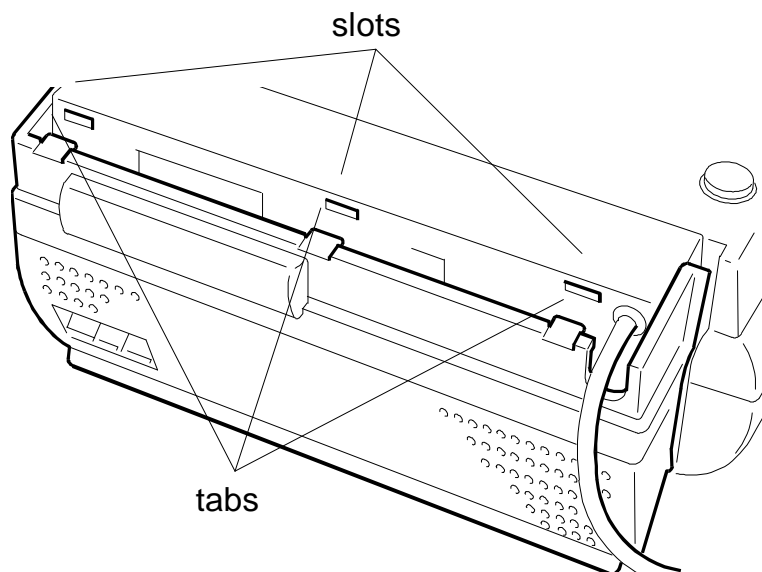
**Fig. 7-19**

**Warning:** during reassembly, make sure that the tabs on the base are correctly inserted into the two slots on the unit (see fig. 7-20, a) and that the three tabs on the cover are correctly inserted into the slots on the unit (see fig. 7-20, b).

a)



b)



**Fig. 7-20**

## 7.2.4 Removing the Power Supply and NCU Boards

- 1) Remove the power supply unit (see section 7.2.3)
- 2) Unscrew the two screws on the shield and remove it (see fig. 7-21)

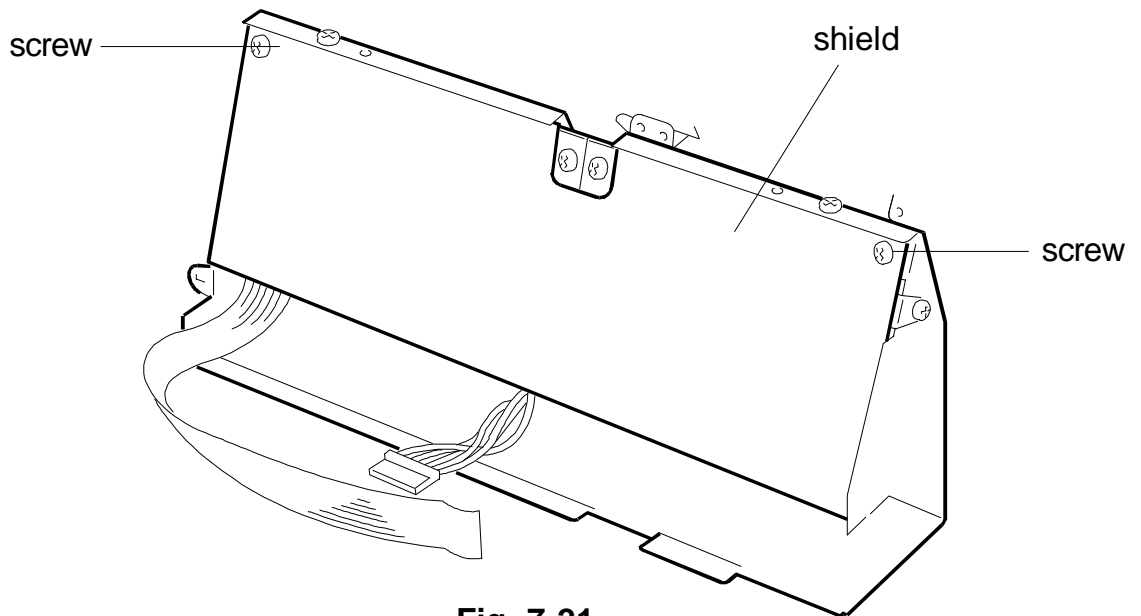


Fig. 7-21

- 3) For the **power supply board**, remove the two screws and ground plate (see fig. 7-22)

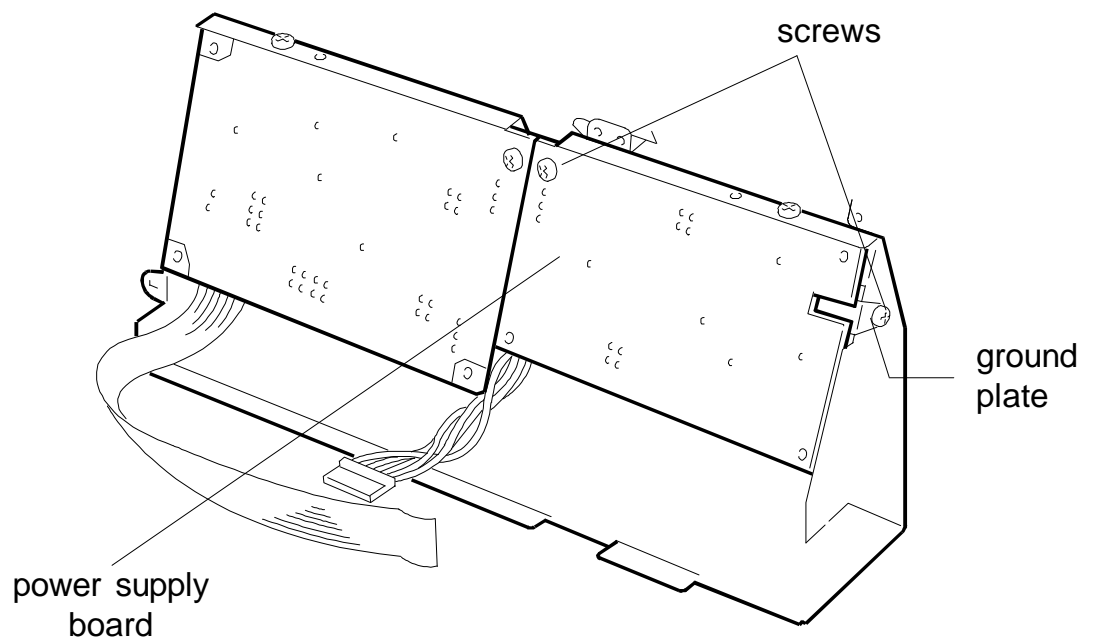
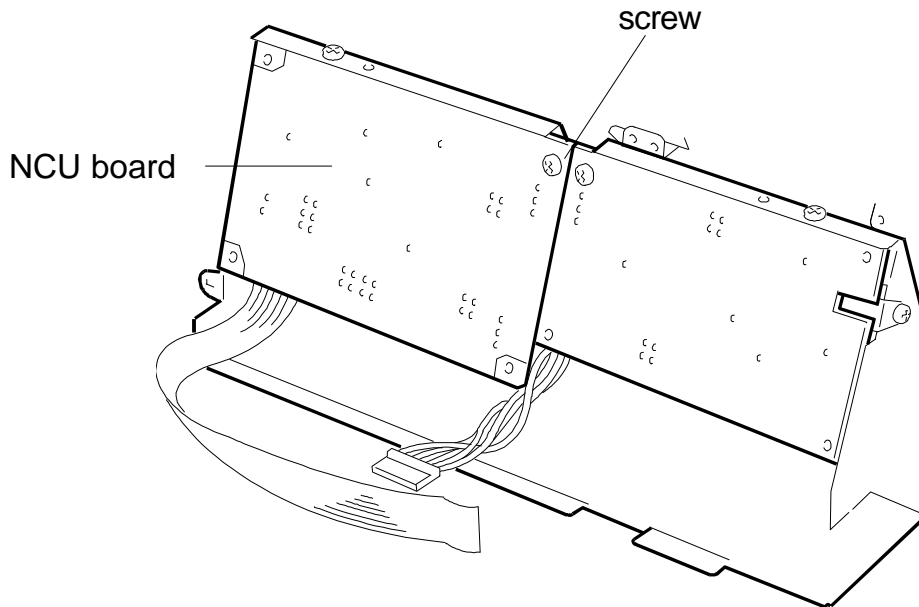


Fig. 7-22

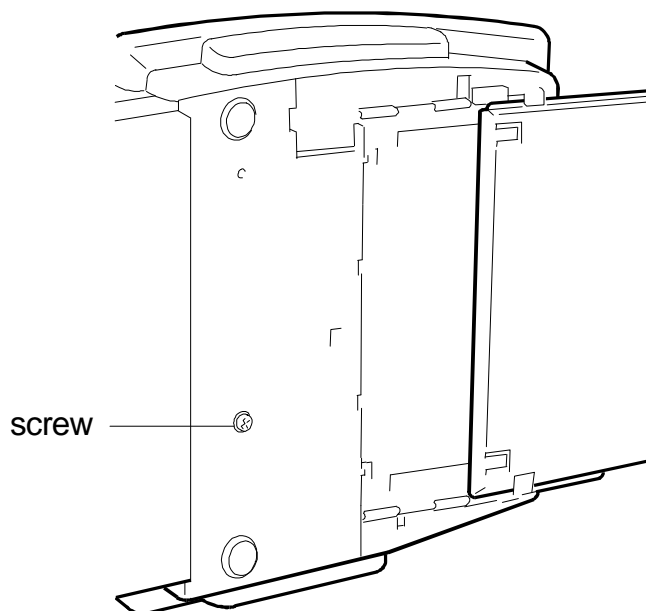
- 4) For the **NCU board**, remove the remaining screw (see fig. 7-23).



**Fig. 7-23**

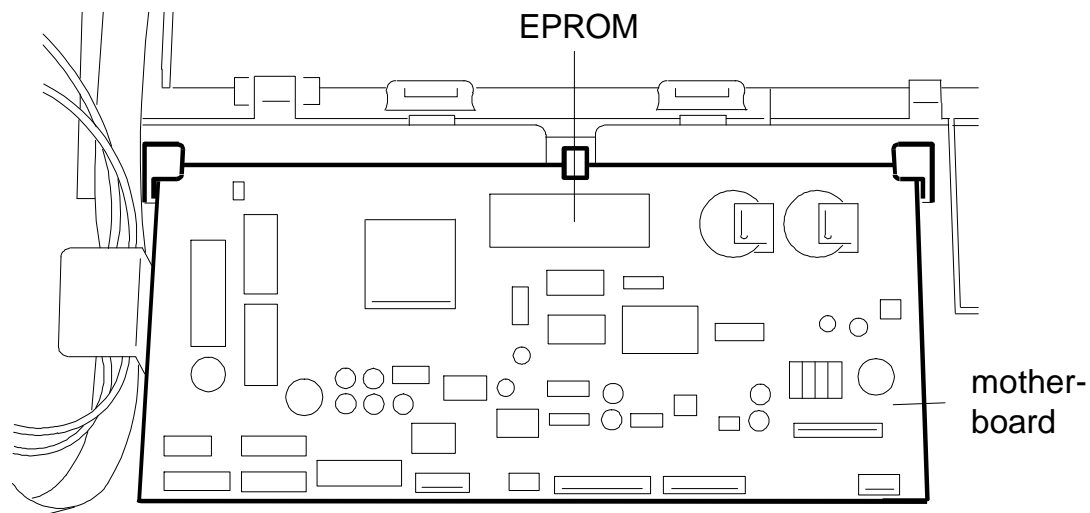
### 7.2.5 Removing the Motherboard and the System Firmware

- 1) Remove the power supply unit (see section 7.2.3)
- 2) Remove the screw on the base (fig. 7-24), free the cables from their clips, unplug all the motherboard connectors and flat cables and pull the motherboard out from the rear



**Fig. 7-24**

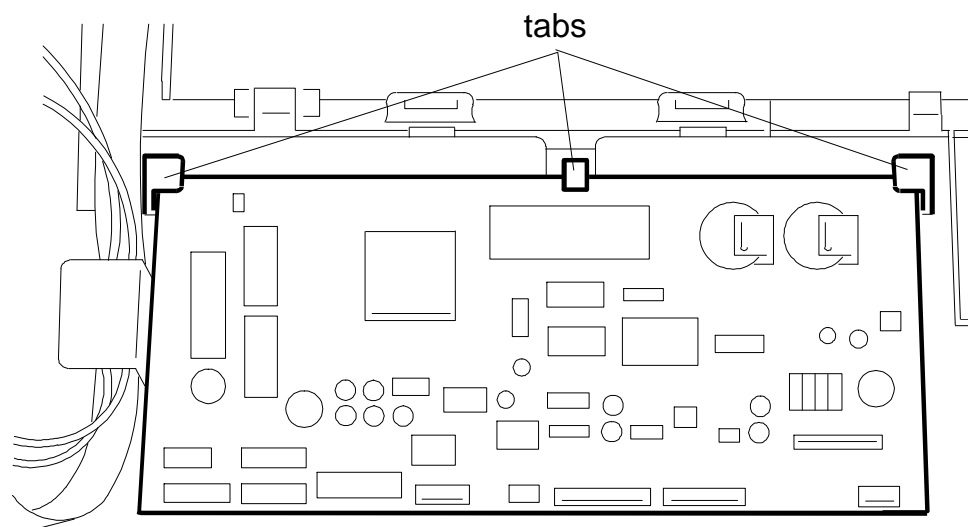
- 3) Remove the EPROM containing the system firmware (see fig. 7-25)



**Fig. 7-25**

- 4) After replacing the motherboard, perform the ALIGNMENT TEST (par. 6.1.1), PRINT CHART (par. 6.1.4) and SCANNER SHADING (par. 6.1.8).

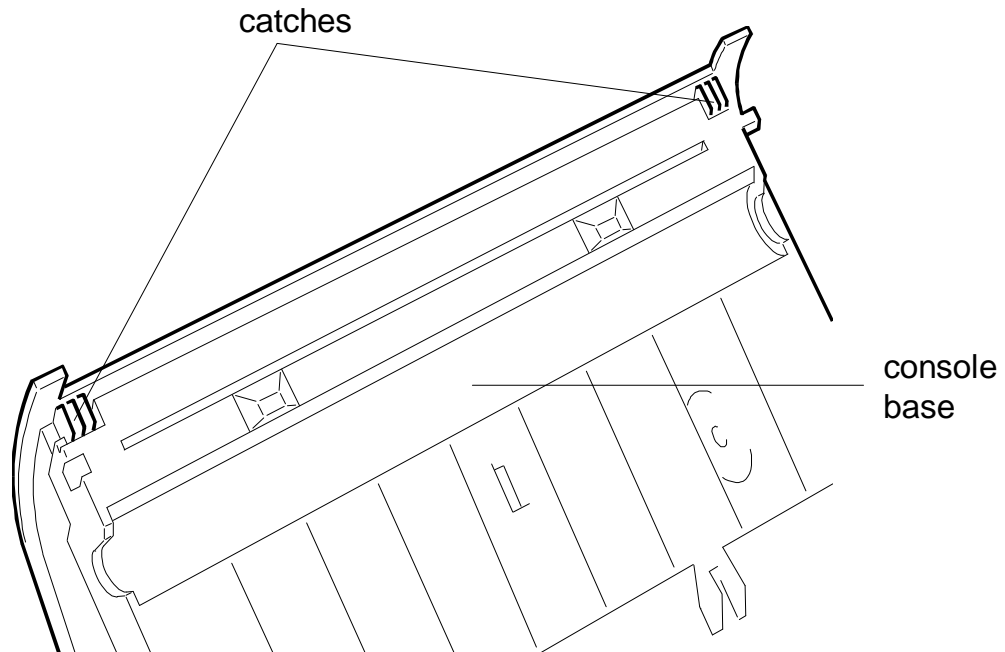
**Warning:** during reassembly, make sure that the edge of the motherboard is correctly inserted under the three tabs on the base (see fig. 7-25a).



**Fig. 7-25a**

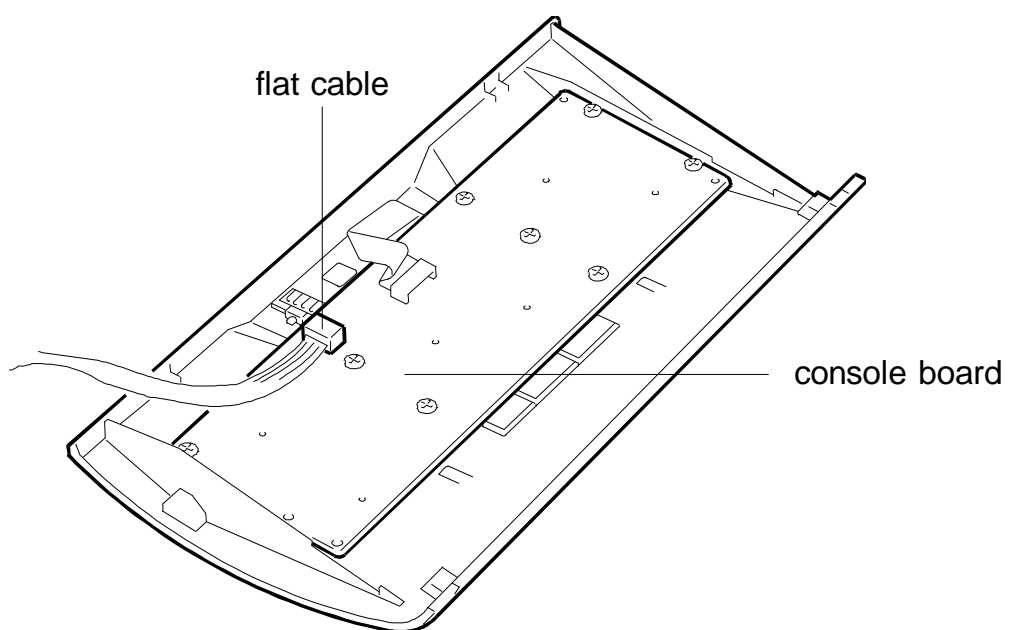
## 7.2.6 Removing the Console

- 1) Tilt the printer cover
- 2) Tilt the console and release it from its base by pressing the catches at the front (see fig. 7-26)



**Fig. 7-26**

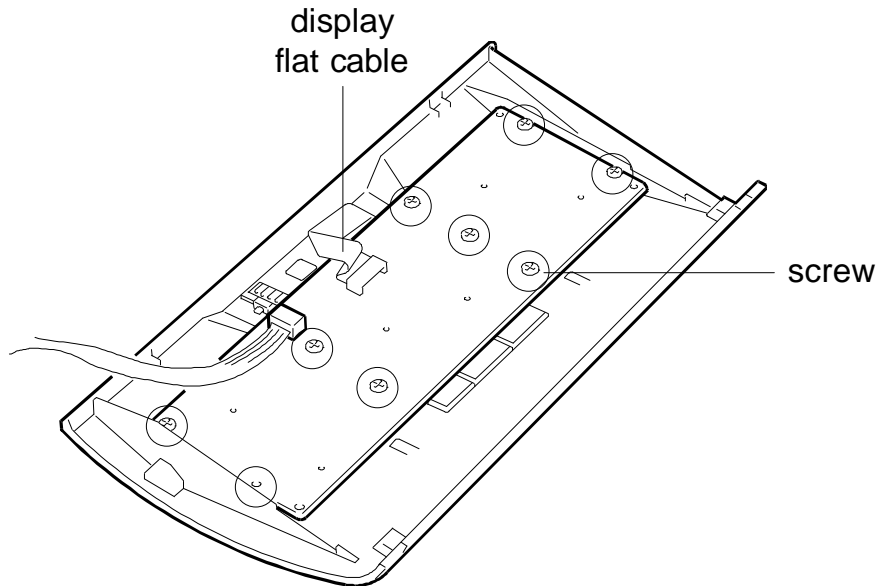
- 3) Unplug the flat cable from the console board so that you can remove the board (see fig. 7-27).



**Fig. 7-27**

## 7.2.7 Removing the Console Board

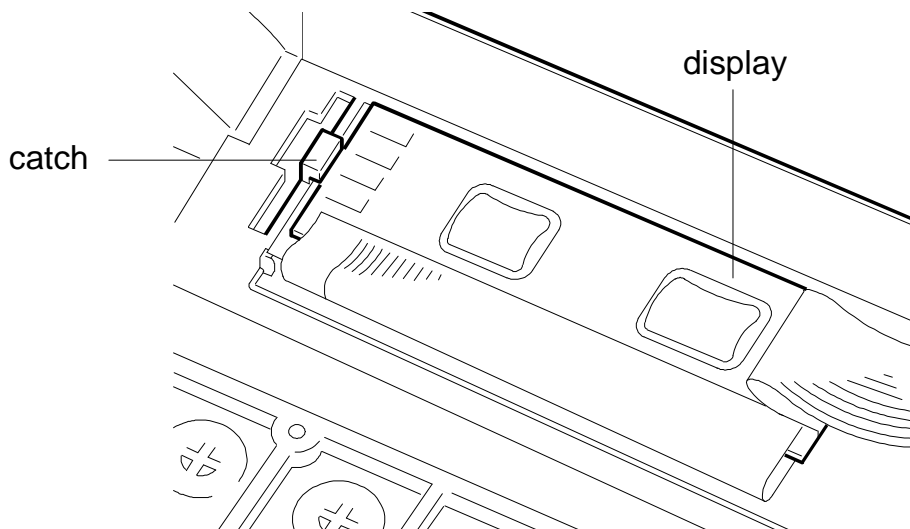
- 1) Remove the console (see section 7.2.6)
- 2) Remove the nine screws and unplug the flat cable of the display (see fig. 7-28), then remove the board.



**Fig. 7-28**

## 7.2.8 Removing the Display

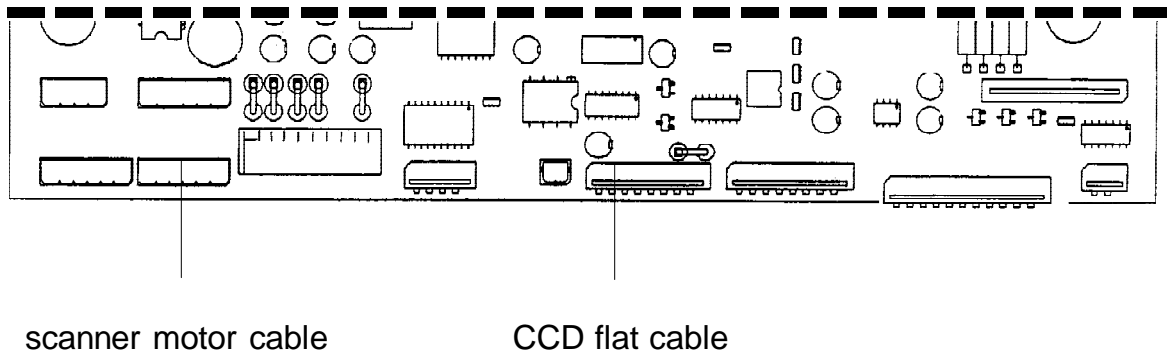
- 1) Remove the console board (see section 7.2.7)
- 2) Press on the side of the display catch and remove the display (see fig. 7-29).



**Fig. 7-29**

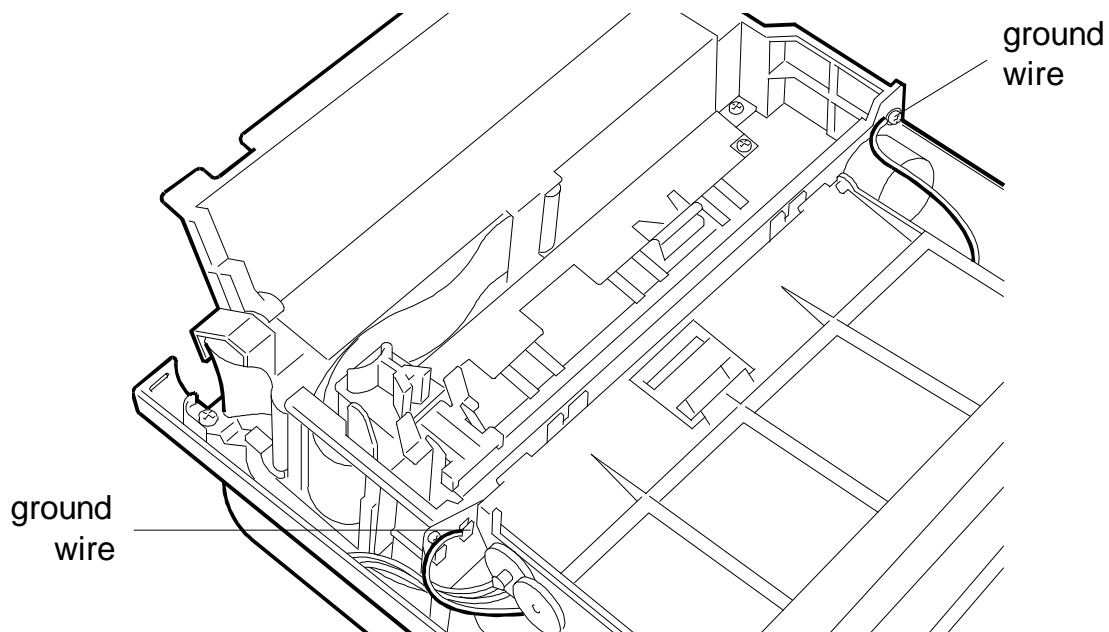
## 7.2.9 Removing the Scanner Unit

- 1) Remove the casing (see section 7.2.2)
- 2) Remove the power supply unit (see section 7.2.3)
- 3) Remove the console (see section 7.2.6)
- 4) Unplug the scanner motor cable and the CCD flat cable from the motherboard (see fig. 7-30)



**Fig. 7-30**

- 5) Lift the scanner unit and pull it forwards so that you can unplug the ground wire on the left and unscrew the right ground wire (see fig. 7-31).



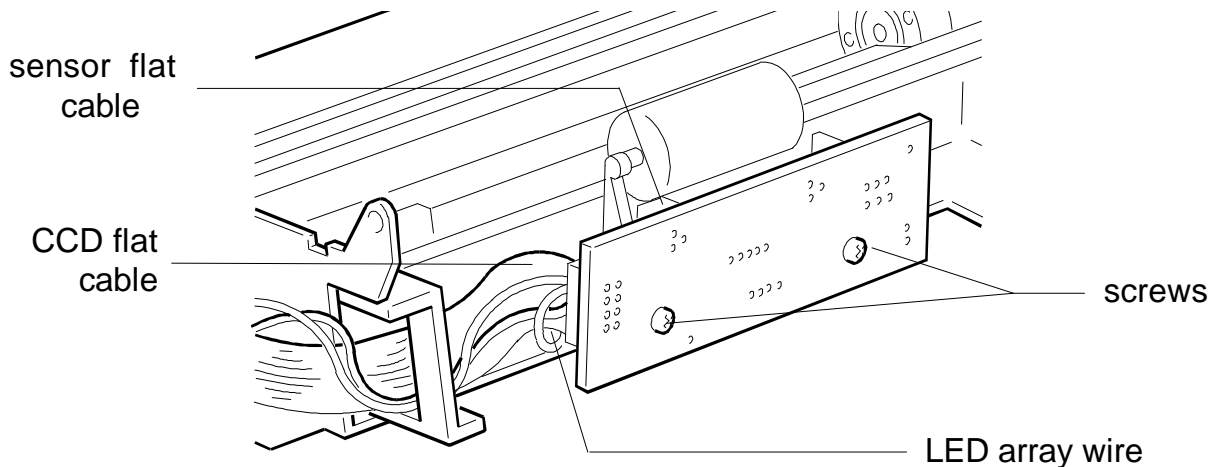
**Fig. 7-31**

- 6) After replacing the Scanner Unit, perform the ADF TEST (par. 6.1.6) and SCANNER SHADING (par. 6.1.8).

## 7.2.10 Removing the CCD Board

***This board must be replaced at the laboratory only!***

- 1) Remove the scanner unit (see section 7.2.9)
- 2) Remove the two screws and move the CCD board away from the scanning unit. Then unplug the CCD flat cable, the sensor flat cable and the LED array wire (see fig. 7-32), and then remove the CCD board

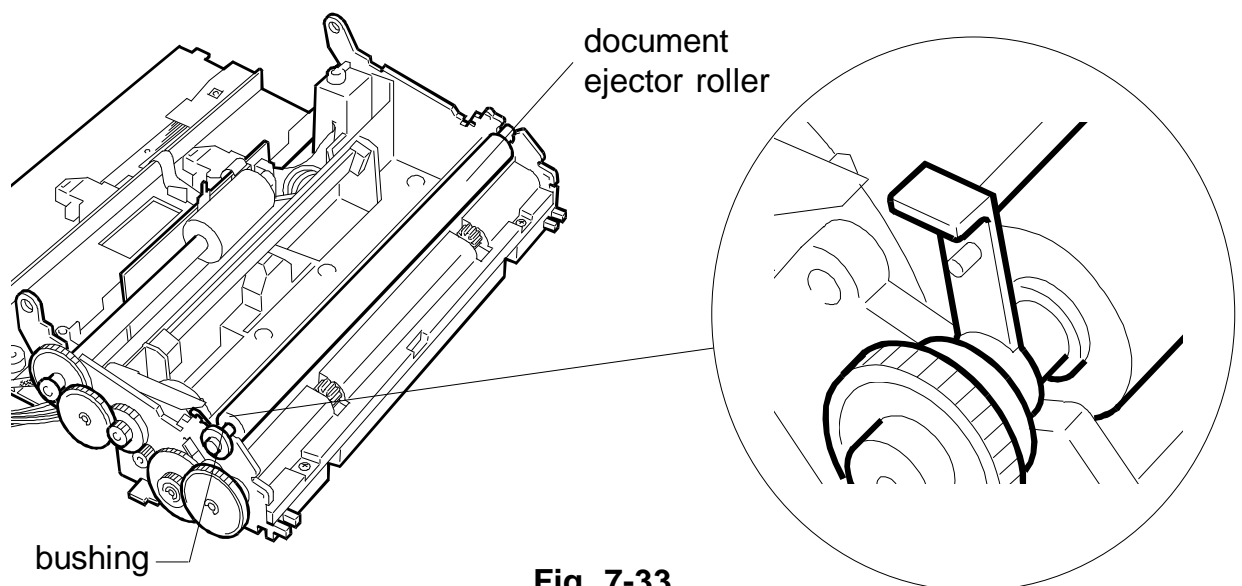


**Fig. 7-32**

**Warning:** having replaced the board, make the CCD adjustment (see section 6.3).

## 7.2.11 Removing the LED Array

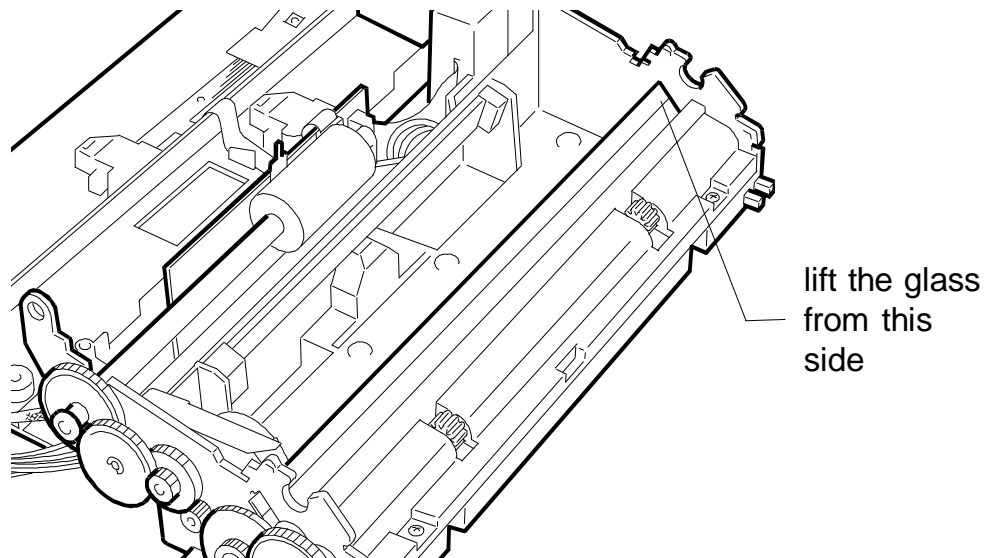
- 1) Remove the scanner unit (see section 7.2.9)
- 2) Release the left bushing on the document ejector roller, by turning it towards the front and slide the roller out from the right-hand side (see fig. 7-33)



**Fig. 7-33**

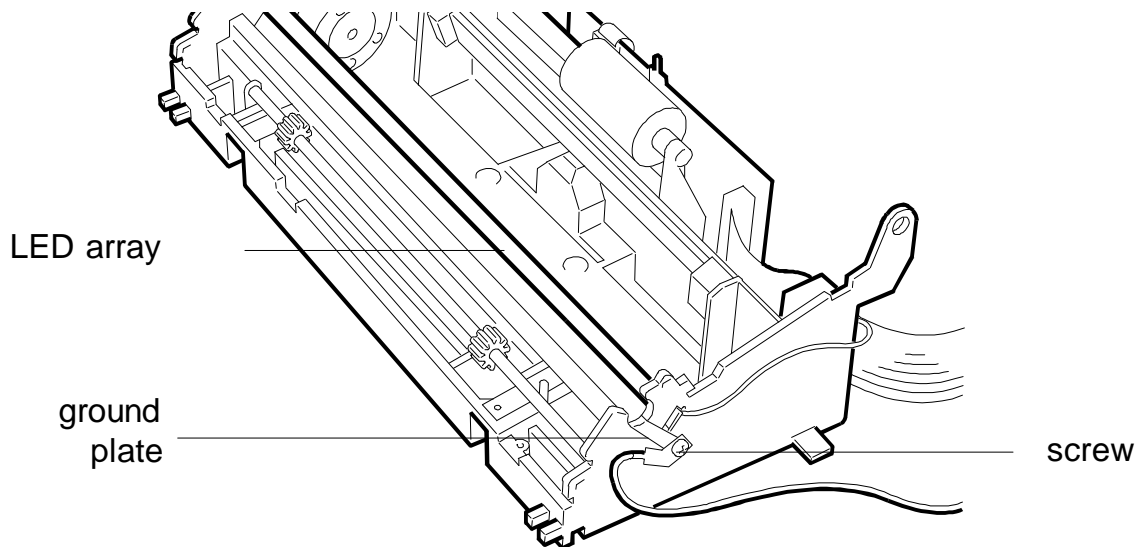


- 3) Lift the right-hand side of the glass and remove it from the left-hand side (see fig. 7-34)



**Fig. 7-34**

- 4) Remove the screw and ground plate (see fig. 7-35), then remove the LED array.

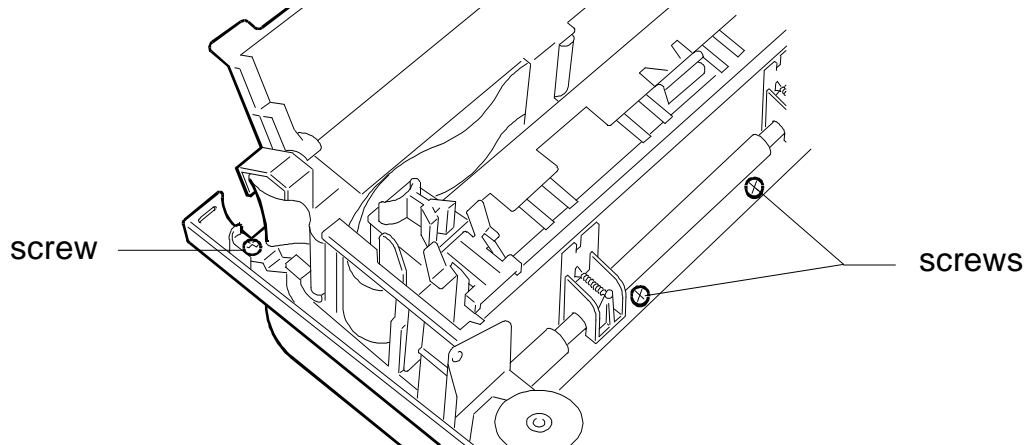


**Fig. 7-35**

## 7.2.12 Removing the Printer Unit

- 1) Remove the power supply unit (see section 7.2.3)
- 2) Remove the scanner unit (see section 7.2.9)

- 3) Remove the two screws at the front and the two screws on the sides (see fig. 7-36), then slide the unit out towards the front.

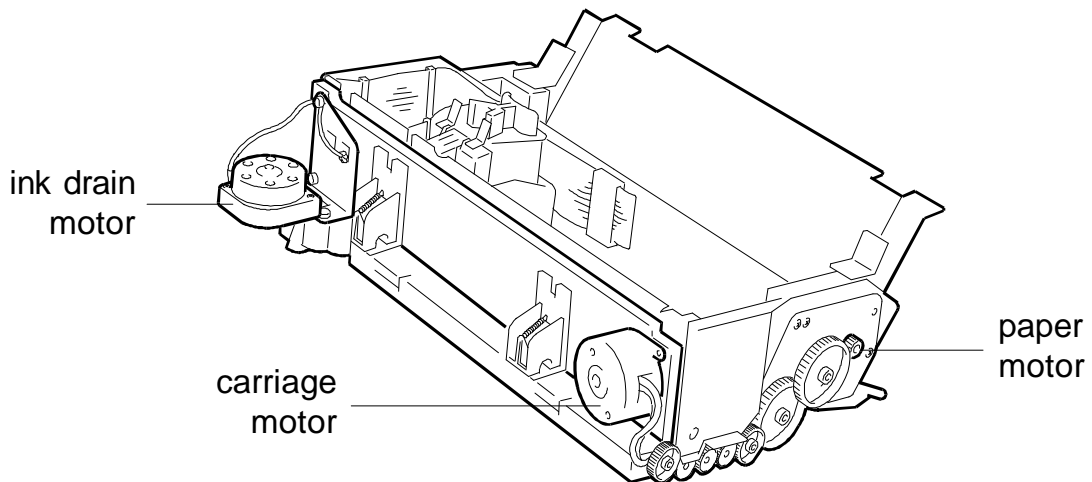


**Fig. 7-36**

- 4) Unplug all the cables from the motherboard.
- 5) After replacing the Printer Unit, perform the ALIGNMENT TEST (par. 6.1.1), PRINT CHART (par. 6.1.4) and ASF TEST (par. 6.1.5).

### 7.2.13 Removing the Carriage, Paper and Ink Drain Motors

- 1) Remove the printer unit (see section 7.2.12)
- 2) Remove the two screws from each motor and free the cables from their clips (see fig. 7-37)



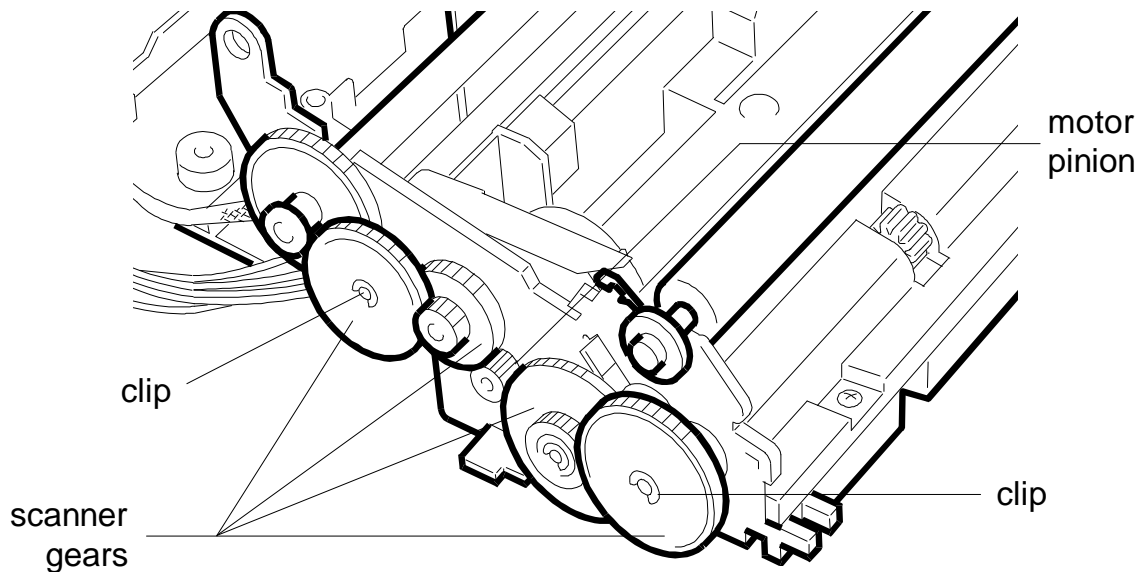
**Fig. 7-37**

- 3) After replacing the carriage motor, perform the ALIGNMENT TEST (par. 6.1.1) and PRINT CHART (par. 6.1.4). After replacing the paper motor, perform the PRINT CHART (par. 6.1.4) and ASF TEST (par. 6.1.5).

**Warning:** for the *paper motor*, first remove the two screws on the flange on which the motor is assembled (see fig. 7-37).

### 7.2.14 Removing the Scanner Motor

- 1) Remove the casing, power supply unit (see section 7.2.3) and console (see section 7.2.6)
- 2) Remove the two clips and scanner gears (see fig. 7-38)



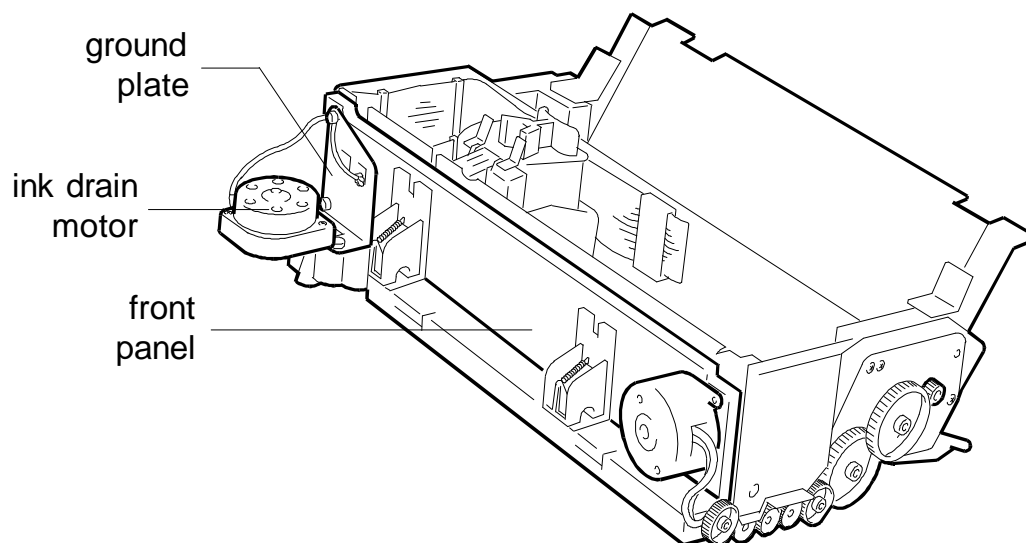
**Fig. 7-38**

- 3) Disconnect the motor cable from the motherboard, remove the two screws on the left-hand side and slide the motor inwards.

### 7.2.15 Removing the Print Carriage

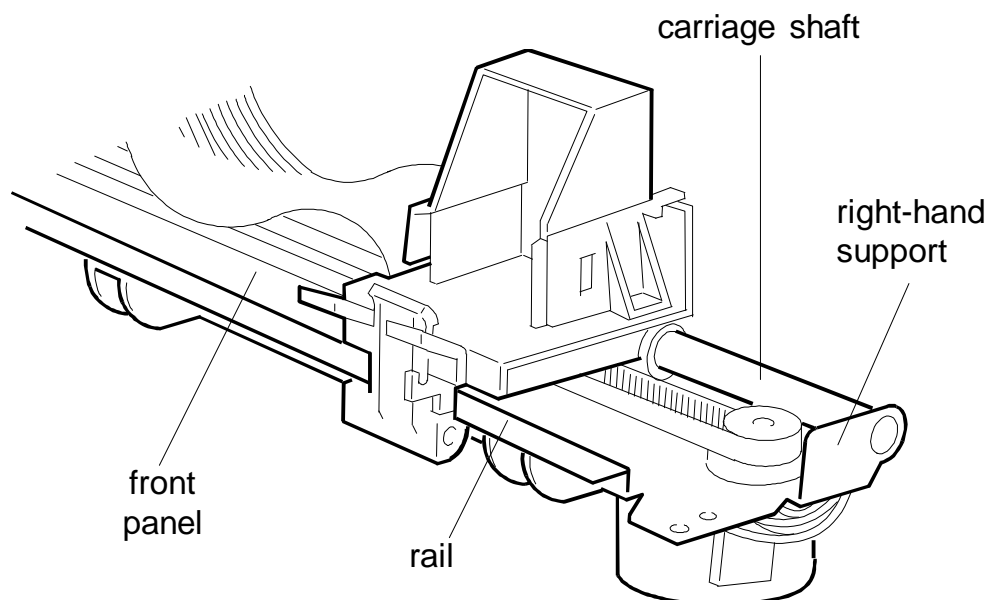
- 1) Remove the printer unit (see section 7.2.12)
- 2) Remove the print head and move the print carriage to the centre
- 3) Unplug the two flat carriage cables from the motherboard
- 4) Unscrew the ink drain motor from its support and move it to one side so that you can get at the screw behind it

- 5) Remove the four screws that secure the front panel and the two that fix the ground plate (see fig. 7-39)



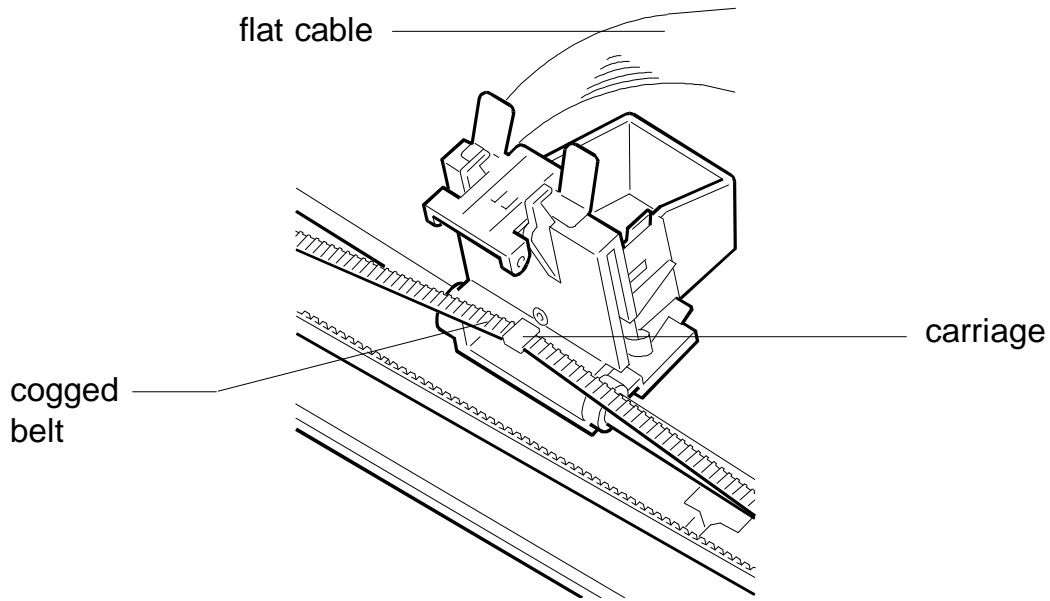
**Fig. 7-39**

- 6) Remove the ground plate and tilt the front panel forward, then bend the right-hand support to free the print carriage rail from both supports (see fig. 7-40)



**Fig. 7-40**

- 7) Release the carriage from the rail on the front panel, then disconnect the cogged belt from the carriage and the flat cable from its clips (see fig. 7-41).



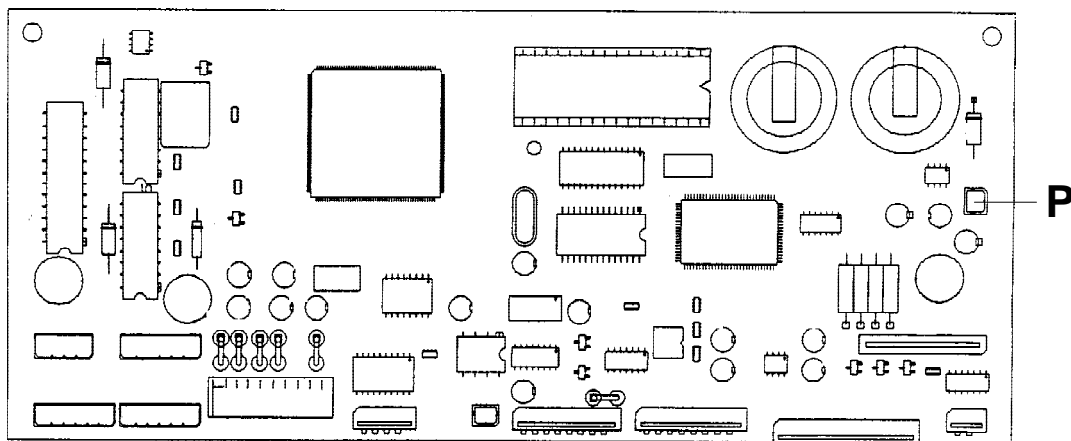
**Fig. 7-41**

- 8) After replacing the carriage, perform the ALIGNMENT TEST (par. 6.1.1) and PRINT CHART (par. 6.1.4).

## 7.2.16 Restoring the facsimile machine

During every disassembly or replacement procedure in which one or more connectors have been unplugged from the motherboard, it is advisable to restore the facsimile machine prior to complete the procedure.

- 1) Remove the motherboard, unplug the short-pin P (see fig. 7-42) and plug it again after one second to be sure that the dynamic memory has been cleared



**Fig. 7-42**

- 2) Reassemble the motherboard and complete the disassembly or replacement procedure
- 3) Power on the facsimile machine and perform LOAD DEFAULT (see par. 6.1.7) to reload the default (U.K.) parameters into the static memory
- 4) Perform the ALIGNMENT TEST (see par. 6.1.1) and SCANNER SHADING (see par. 6.1.8) to reload the calibration values into the static memory
- 5) Perform the country set-up (see par. 3.2.2) to reload the current national parameters into the static memory
- 6) Restore all configuration parameters to their original current values (refer to the configuration print-outs you have obtained before starting the disassembly or replacement procedure)
- 7) Restore the user's telephone list.

## 8. OPTIONAL DEVICES

The facsimile machine offers the following optional features:

- *Back to back connection*
- *Telephone answering device*
- *Extension telephone connection*
- *Handset*

## 8.1 SETTING UP A BACK TO BACK CONNECTION

The **back to back connection** between facsimile machines of the same model or line of products does not require any particular setting: simply connect the two facsimile machines with a telephone cable plugged into the LINE socket on each machine (fig. 8-1).

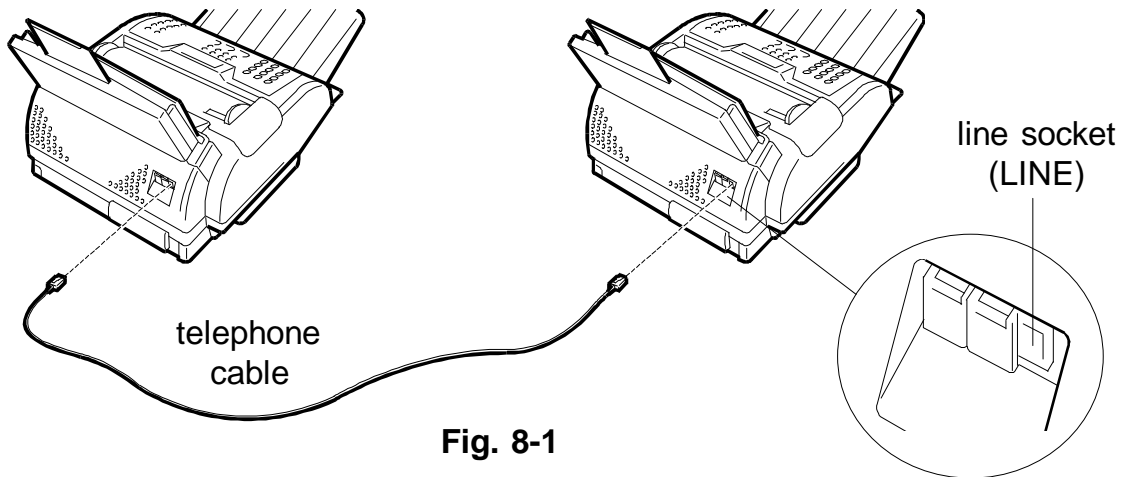


Fig. 8-1

## 8.2 CONNECTING A TELEPHONE ANSWERING DEVICE

- 1) Remove the precut tab covering the socket for the TAD (TEL2) and plug the cable of the answering device into this socket (Fig. 8-2).

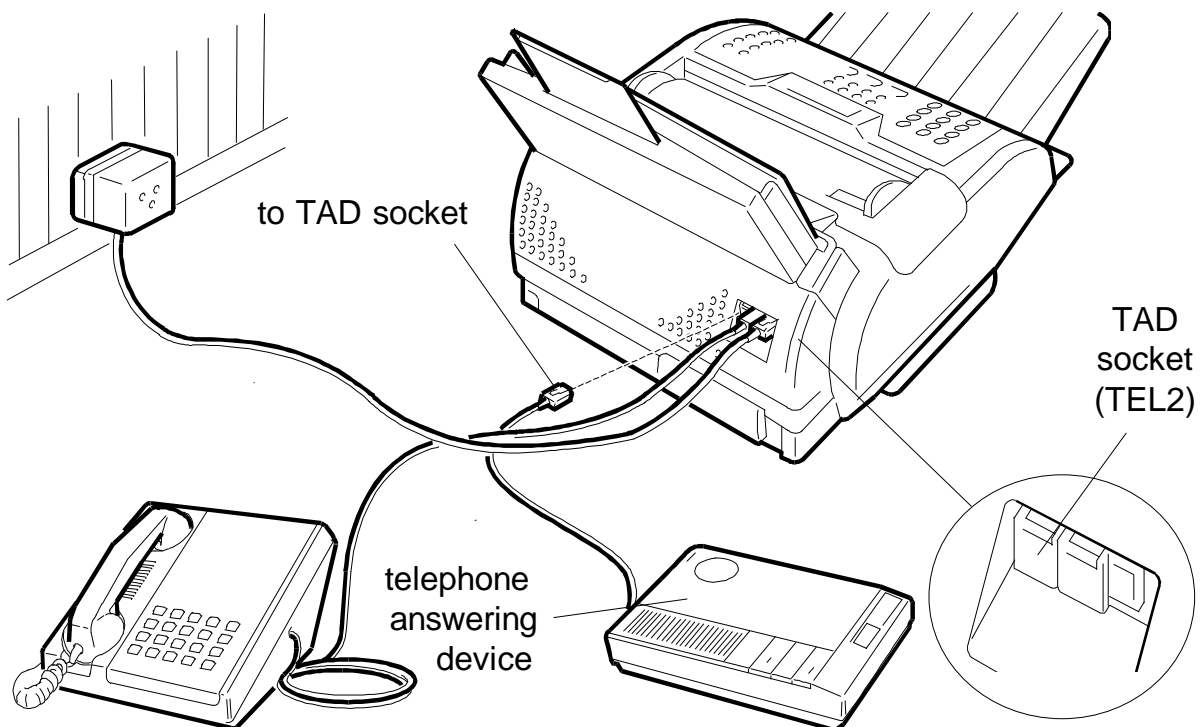


Fig. 8-2

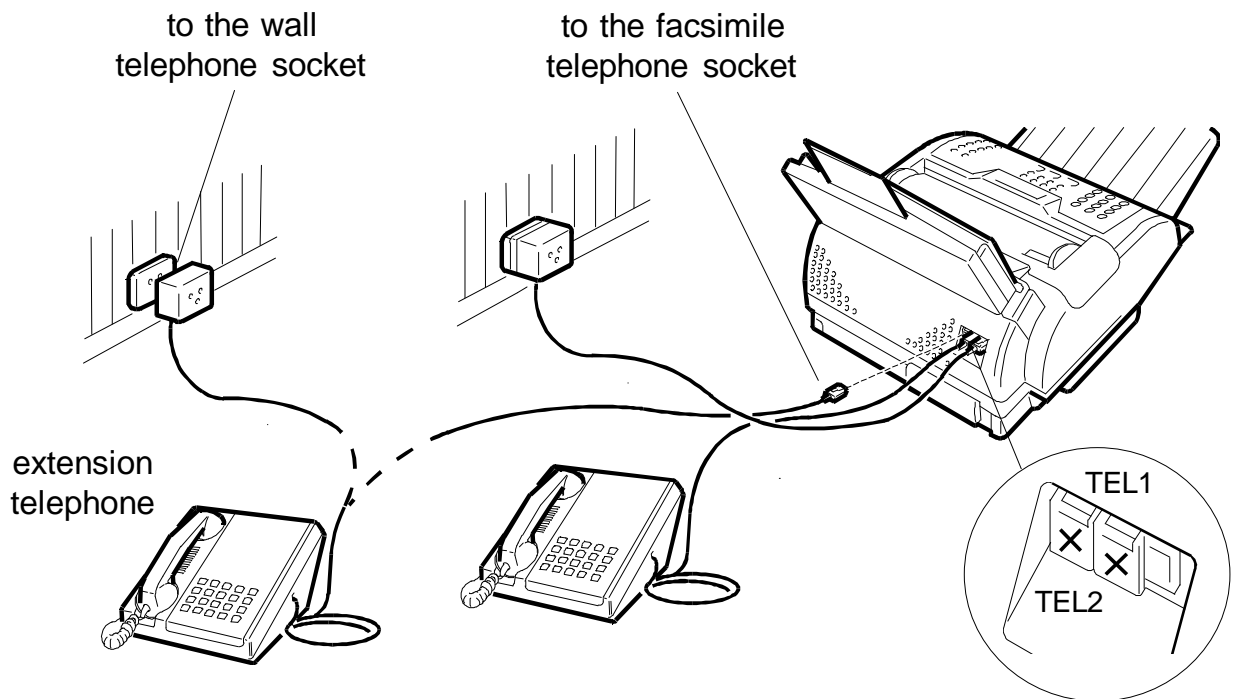


2) Press the RX MODE key until the TAD/FAX RX option appears on the display.

**Warning:** to ensure that the TAD will work properly, check that the silence time (service switch **SWO**, section 4.1) is less than the TAD's time.

### 8.3 CONNECTING A TELEPHONE EXTENSION

A telephone extension can be connected, in the same way as any other telephone that may already be connected, either to the wall telephone socket or to the free telephone socket on the facsimile machine (TEL1 or TEL2) (fig. 8-3).



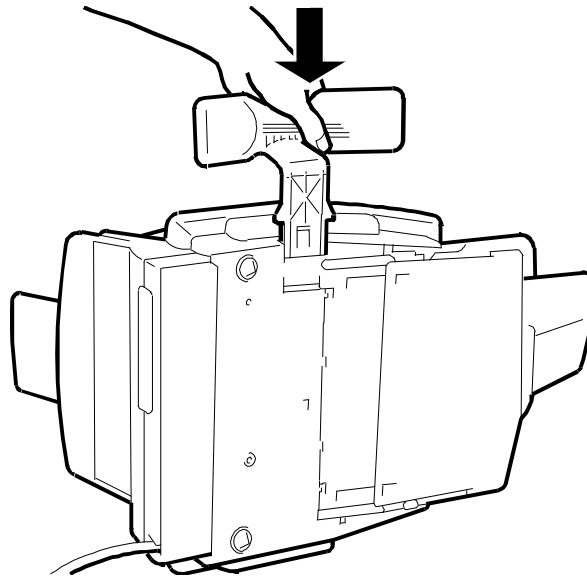
**Fig. 8-3**

Any telephone connected to the facsimile machine, either directly or as an extension, can be enabled to activate the facsimile machine by means of a **one-digit code** (see section 3.2.4).

## 8.4 HANDSET

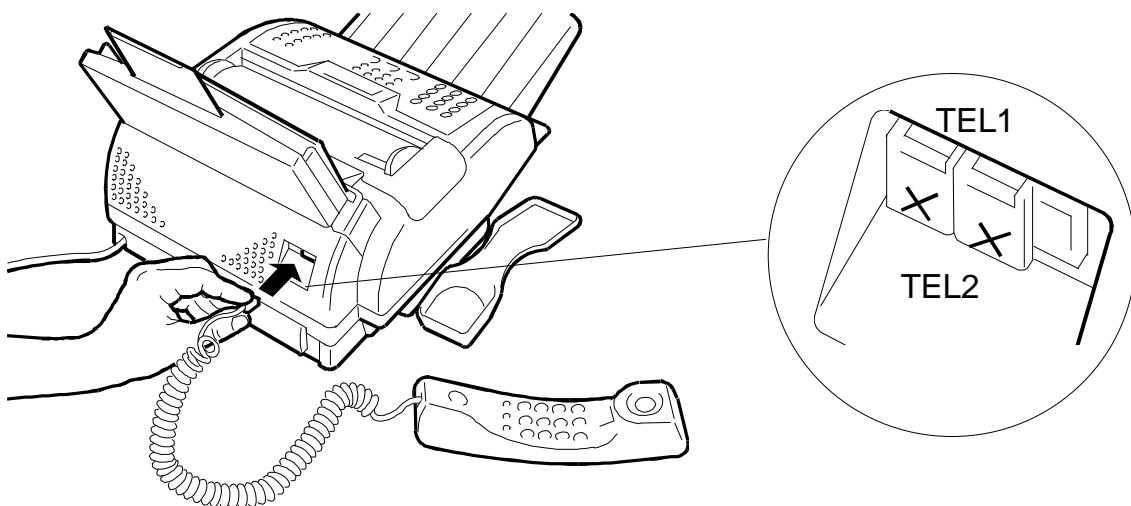
The facsimile machine can be fitted with a holder on its side for a handset, which is to be connected to one of the telephone sockets on the facsimile machine (TEL1 or TEL2).

- 1) Insert the handset holder in its seat on the base of the machine until it clicks into position (fig. 8-4)



**Fig. 8-4**

- 2) Plug the handset cable into the free telephone socket on the facsimile machine (fig. 8-5) and then place the handset on the holder.



**Fig. 8-5**

# 9. INSTALLATION OF THE LINKFAX 8 MODULE IN WINDOWS 95 ENVIRONMENT

## CONTENTS

---

1	INTRODUCTION .....	2
	SYSTEM REQUIREMENTS .....	2
	CONNECTING THE FACSIMILE MACHINE TO THE PC .....	2
	PRINT HEAD PRECAUTIONS .....	3
2	INSTALLING THE LINKFAX 8 MODULE .....	4
	NOTES ON THE USE OF THE COMMUNI- CATION PORT .....	5
	UPDATING THE LINKFAX 8 MODULE .....	8
	TEMPORARY DISABLING OF THE LINKFAX 8 MODULE .....	9
	UNINSTALLING THE LINKFAX 8 MODULE .....	9
	ACCESSING ONLINE HELP .....	9
	PRINTING THE USER GUIDE .....	9
	CREATING 3.5" INSTALLATION DISKETTES .....	10
	INSTALLING LINKFAX 8 USING 3.5" DISKETTES .....	11
	INSTALLING ADOBE READER USING 3.5" DISKETTES .....	11

# 1 INTRODUCTION

**LinkFax 8** is a software communication module that transforms bubble ink jet facsimile machines into **multifunctional products** running under **Windows 95**.

In fact, once they have been **connected to a Personal Computer**, they may be used above all as a **graphic printer**. Documents such as letters, drawings or spreadsheets prepared using standard **Windows** applications may therefore be **printed by the facsimile machine**.

Alternatively, they may be used as a **scanner** for acquiring images and documents on the PC. This is made possible by the TWAIN module, which supplies the standard protocol between the facsimile machine and most popular image processing applications.

Again, with the aid of a fax application (for example, the Windows 95 Microsoft Fax), all kinds of documents (texts and images) **can be sent directly from the PC**. In addition, incoming fax messages can be **stored on the PC**, and subsequently displayed and processed using standard **Windows** applications.

finally they permit transmission and reception of faxes as **electronic mail attachments** using the **Internet** channel.

This guide describes how to install the LinkFax 8 module in Windows 95. The LinkFax 8 module is supplied on **Compact Disk** and comes with the following:

- this **"Installation"** guide
- one **parallel cable**
- one **print head container**.

Instructions on how to use the various functions of **LinkFax 8** are available both **on-line** (specific Guide) and in **printable format** (User Guide).

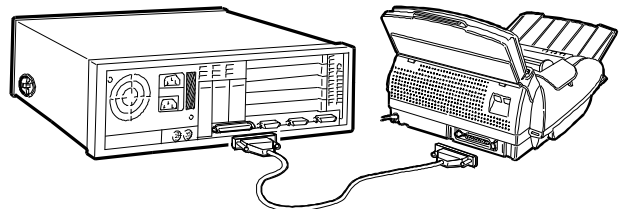
## SYSTEM REQUIREMENTS

The **LinkFax 8** module can only be installed on an **IBM-compatible** PC with the following **recommended minimum configuration**:

- processor **486**
- RAM **8 Mbytes** or more
- monitor **VGA** or higher
- operating system **Windows 95**
- **CD ROM** unit.

## CONNECTING THE FACSIMILE MACHINE TO THE PC

The facsimile is connected to the PC by means of the **parallel cable**, as shown below:



### WARNING

The **protection cover must be removed** before the parallel port of the facsimile can be accessed.

If you are linked to the Internet and wish to **use your one telephone line for both the facsimile machine and the PC modem** (either built-in or external), the following connections will need to be made:

**1**

Refer to the **Instructions for Use** of the facsimile machine for a description of how to connect the facsimile, telephone and PC modem.

**2**

Make sure that the **number of rings before automatic** answer programmed for the PC modem, is **greater than** the number of rings programmed for the facsimile machine.

## PRINT HEAD PRECAUTIONS

The bubble ink jet facsimile machine uses both monochrome (black) and colour print heads:

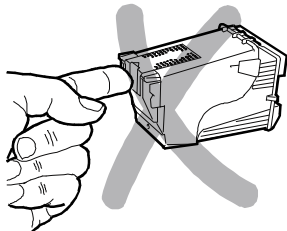
- **monochrome**, for use with the **facsimile**, or the **printer** in **black and white** mode;
- **colour**, for use with the **printer** in **colour** mode.

### WARNING

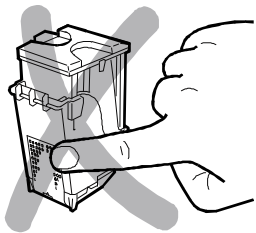
When the colour print head is installed, the documents received will **not be printed straight away**, but stored in the memory of the facsimile machine. Once the memory is full, the facsimile will no longer be able to receive documents, so **always remember** to replace the monochrome print head each time the facsimile is reset.

Since it will be necessary to change the print head regularly, depending on what the facsimile is to be used for, take note of the following precautions:

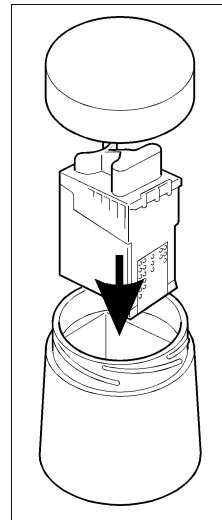
- **do not touch, or stand** the print head on the **ink jets**:



... or the **contacts**:



- **never try to re-load** the print head, as this could damage the print head or the facsimile;
- always place the **print head not in use** in the special container:



This will ensure long life and efficiency of the print head and a high print quality.

- Try **not to get ink on hands or clothes**, as it is very difficult to remove.

### VERY IMPORTANT

The facsimile machine automatically recognises the type of print head installed and checks the level of ink remaining by means of a special internal counter. When there is no ink remaining, the message **OUT OF INK** appears on its display.

In order for the ink level monitored by the internal counter to be consistent with the actual level contained the print head, **never install the print heads of one facsimile machine onto another facsimile machine or bubble ink jet printer.**

## 2 INSTALLING THE LINKFAX 8 MODULE

The **LinkFax 8** communication module consists of **four main components**, which can be selected individually:

- 1 LinkFax Scanning and Internet Application.** Acquires black and white images via the facsimile machine (scanning), irrespective of the application that will be used to process them. It can also be used to partially process acquired images, to save images in the desired format and to send them as electronic mail, if this feature is available. Furthermore, it can be used to partially process colour images loaded from the PC.
- 2 TWAIN.** Acquires images from within the application that will be used to process them. TWAIN therefore provides a standard interface between the facsimile machine and most popular picture processing applications.
- 3 Printer driver.** Handles the facsimile machine as a **printer** attached to a PC.
- 4 Fax Manager.** Enables the facsimile machine to be used as a **multifunctional** product, which can be run simultaneously with other applications. Since the Fax Manager component is essential to the running of LinkFax 8, it is always installed automatically and cannot be selected.

The Compact Disk supplied with the kit also contains the installation program. This program guides you through a series of dialog boxes to enable you to install what you require onto the hard disk of your PC.

### WARNING

The following general conditions apply to the dialog boxes that appear during the installation procedure:

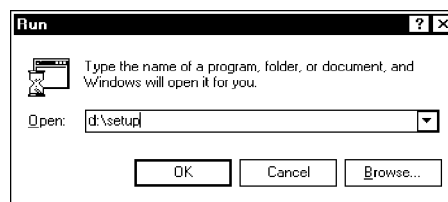
- **optional elements** can only be **selected using the mouse**;
- **buttons** can be **selected** either using the mouse, or by pressing the **→** and **Ⓜ** arrow keys;
- the **selected button** can be confirmed using the **mouse**, or by pressing the **Enter** key.

**1**

Power on the PC, wait for **Windows 95** to start and then insert the **CD in the CD ROM drive**.

**2**

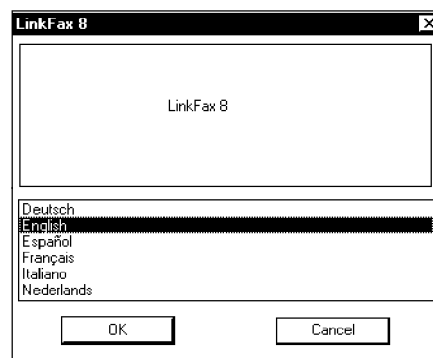
From the **Start** menu, select **Run** and type **x:\setup**, where **x** is the name of the CD ROM drive (for example, **d**):



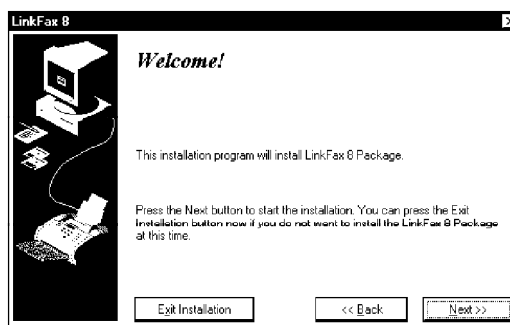
... then click on **OK** to confirm.

**3**

Select your **mother language**, if it is not already selected:



... and click on **OK** to confirm. A welcome message is displayed explaining how to continue (**Next >>**), or abort the installation procedure (**Exit Installation**):



## WARNING

You can abort the installation procedure from any of the dialog boxes that appear from now on. If you decide to abort the procedure, the **program will request confirmation (Yes)**:



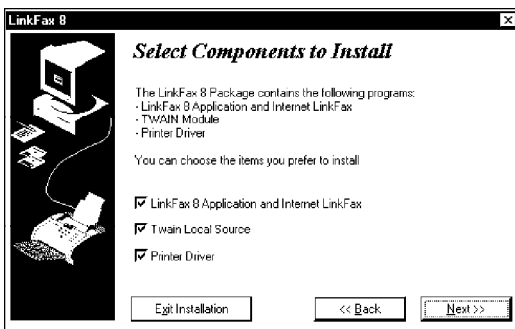
and then return to Windows 95.



If you abort the installation procedure, **none** of the items selected **will be installed**.

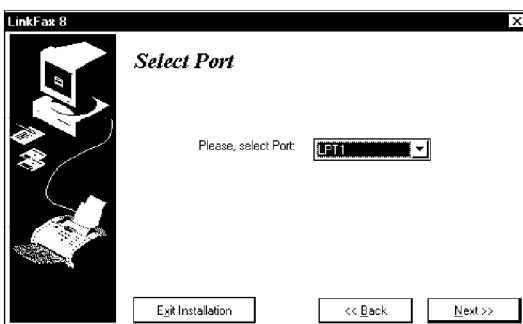
**4**

Select the **components** you wish to install:



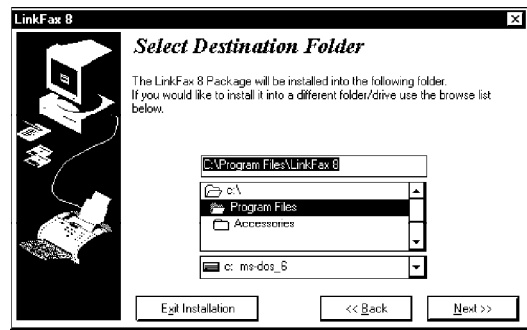
**5**

Select the **port** to which the facsimile machine has been connected:



**6**

Select the folder in which you wish to install the LinkFax 8 module from the **folder** list (the **Programs/LinkFax 8** folder is automatically selected):

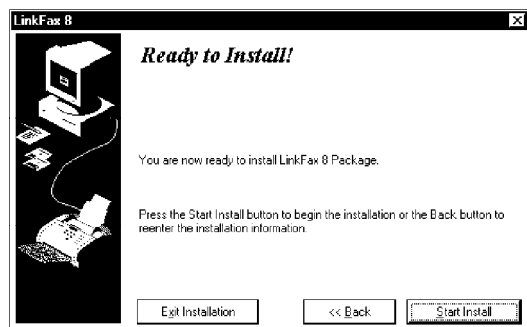


## WARNING

The **LinkFax 8** item is automatically inserted in the **Start** menu.

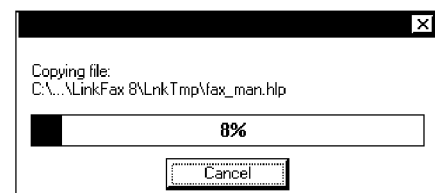
**7**

You have now finished selecting what you wish to install. You can either return (<< **Back**) to the previous dialog boxes to check your settings, or you can continue:



**8**

**Start Installation.** A dialog box enables you to keep track (in %) of the files being installed from the CD to the hard disk ...



... together with some messages introducing you to the features of the LinkFax 8 module.

## WARNING

If you click on **Cancel** while the files are being loaded, this will interrupt the installation procedure and cause the system to restart.

## 9

On completion of the installation procedure, a dialog box prompts you to install the modem:



- You can select **Install now** and confirm (**OK**):
  - if you already have a modem installed, the standard Modem properties **window is opened**:
    - a. confirm the **Add** button;
    - b. select **Don't detect my modem; I will select it from a list** and confirm (**Next**);
    - c. select the **LinkFax** item from the Manufacturers menu and the **LinkFax 8** item from the **Models** menu and then confirm (**Next**);
    - d. select the **port** to which the facsimile machine has been connected and confirm (**Next**);
    - e. once the selected modem has been retrieved, confirm by clicking on the **Finish** button;
    - f. confirm the **Close** button.
  - if you have no modem installed, the standard **Install new modem** window is opened:
    - a. follow steps **b**, **c** and **d** of the above procedure;
    - b. when the standard **Modem properties** window appears, click on **OK** to confirm;
- Alternatively, you can select **Install later via Control Panel** and then click on **OK** to confirm.

### WARNING

If you selected the printer driver at step **4**, go to step **10**; if you did not, go straight to step **11**.

## 10

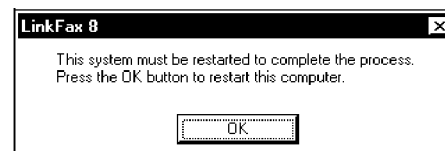
The Windows 95 **Printer Installation** guide appears. Select the following parameters where required:

- **Local printer**;
- Manufacturer: **LinkFax 8**, which corresponds to Model: **LinkFax 8 Color Printer**;
- Port: that to which the facsimile is connected (**Fax port**);
- Printer name: confirm the predefined name (**LinkFax 8 Color Printer**), or enter another name as required, then click on **Finish**.

The procedure automatically proceeds to the next step.

## 11

A dialog box prompting you to restart the system appears:



## 12

Confirm (**OK**); the following message appears:

### Restarting Windows ...

which remains until the end of the restart cycle.

## 13

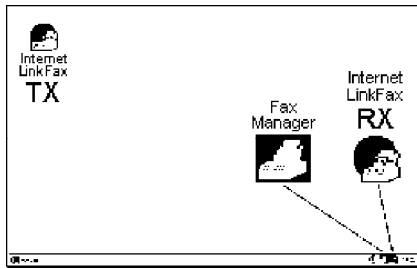
Remove the CD and check that the **LinkFax 8** item has been added to the **Programs** menu, together with any components you have installed: **Scanner application, Uninstaller, Internet LinkFax, Printer**. **Specific guides** are displayed for each of the components installed (marked by a book icon). These include:

- the **User Guide** item, which supplies instructions for printing the **Instructions for use** of the LinkFax 8 module.
- the **Printer** item, which allows for the selection of the associated **Guide** and the **Status Monitor**.

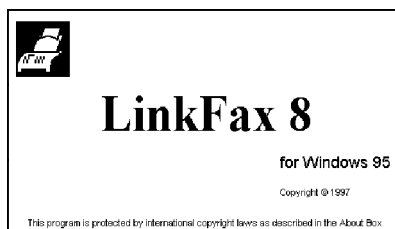
The **installed components** of the LinkFax 8 module are now **active** within Windows 95 and are represented by **icons** which appear at the bottom of the screen: **Fax Manager** and **Internet**



**LinkFax** icons for reception, plus an **Internet LinkFax** icon for transmission, which appears further up the screen.



In addition, from this point on, whenever the system is restarted, the following picture will appear on the display for a few seconds:



**WARNING**

If no **E-mail** application has been installed, the **Internet LinkFax** icon will not appear at the bottom of the screen and the icon that appears on the screen will not be active. Furthermore, each time the system is restarted, the following message will appear:



... to remind you that you do not have access to any E-mail applications.

The two **Internet LinkFax** icons are automatically reset following installation of an E-mail application.

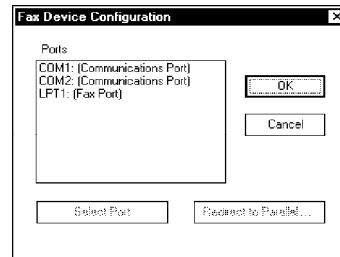
**NOTES ON THE USE OF THE COMMUNICATION PORT**

Having installed the LinkFax 8 module, the PC port to which the facsimile machine is connected will be **exclusively dedicated to the management of bubble ink jet facsimile machines** (Fax Port)

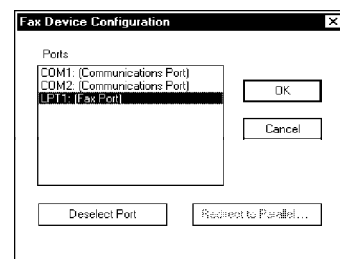
supported by the module.

Should you need to use this port for devices other than facsimile machines, you can **temporarily deselect** the port and then reselect it:

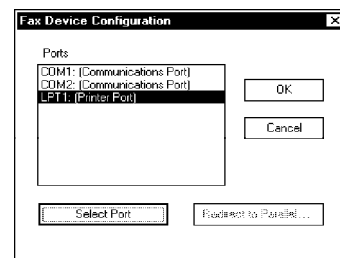
- Double click on the Fax Manager icon:



- Select the **fax port** (LPT1 in the example):



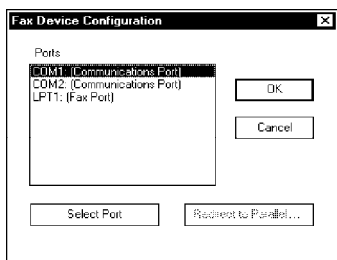
- Confirm the **Deselect port** button to enable the port for **standard operation** (Printer Port):



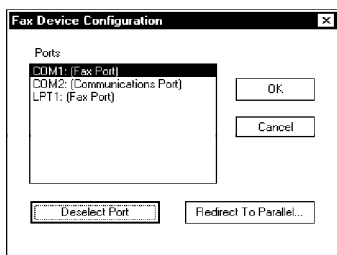
- To reselect the Fax Port, you will have to confirm the **Select Port** button.

If you are using an application that can only control the facsimile machine **via a serial port**, you can **temporarily redirect the serial port to the parallel port**. In this way, the application will "think" that it is using a serial port, while in reality the facsimile machine is controlled via the parallel port.

- Double click on the Fax Manager icon and select the relevant **serial port** (COM1 in the example):

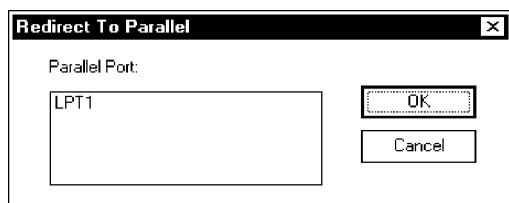


- Confirm the **Select Port** button:

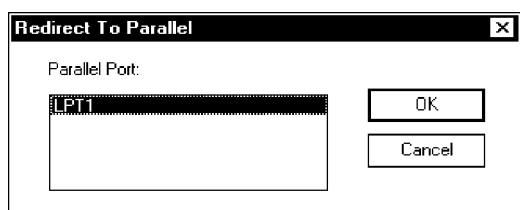


The **Redirect to Parallel** button is now active.

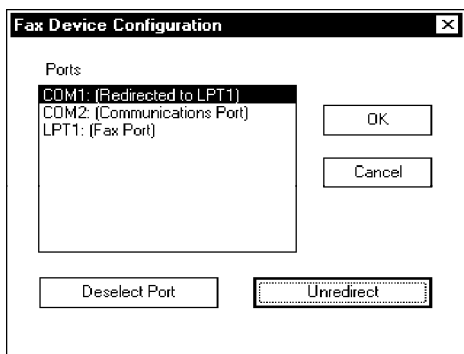
- Confirm the **Redirect to Parallel** button:



- Select the **parallel port** to which you wish to redirect the serial port (**LPT1** in the example):



and click on **OK** to confirm:



- Complete the procedure by clicking on **OK**.
- Click on the **Unredirect** button to restore standard port management.

## UPDATING THE LINKFAX 8 MODULE

Having performed the initial installation of the LinkFax 8 module, you may need to carry out one of the following procedures:

- **Adding components** to a previous partial installation: repeat the installation procedure by selecting the required elements. Since Fax Manager cannot be selected, it will be reinstalled.
- **Installing a new version** of the current module:

### 1

Carry out the installation procedure up to the point where you have selected and confirmed your mother language; this time a message will appear informing you that **the module is already installed** and giving instructions on how to continue:



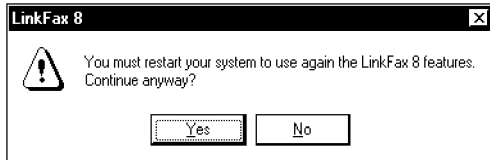
### 2

Continue by selecting the components and applications you require: during the installation procedure the new elements will be **added** to those already installed in the previous version, and the existing elements will be **updated**.

## TEMPORARY DISABLING OF THE LINKFAX 8 MODULE

1

Click on the **Fax Manager** icon at the bottom of the screen with the **right mouse button**. Then click on **Exit** on the **Device configuration** menu.



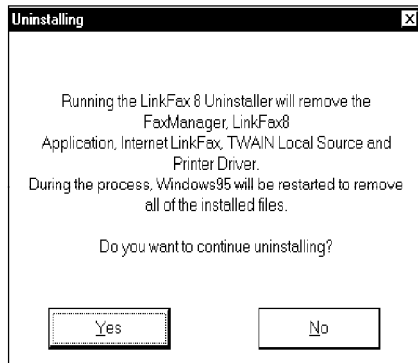
2

Confirm (**YES**): the features of the LinkFax 8 module are **disabled** and will be automatically activated again the next time the system is restarted.

## UNINSTALLING THE LINKFAX 8 MODULE

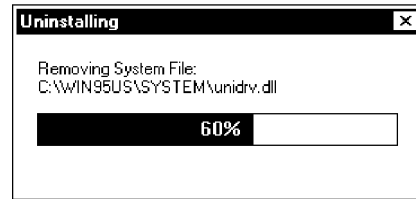
1

Select **Uninstaller** from the **LinkFax 8** menu on the **Programs** menu:



2

Confirm uninstallation (**Yes**): the LinkFax 8 module is removed, together with all its links (menus, items, icons):



Windows 95 is restarted as at the end of the installation procedure.

## ACCESSING ONLINE HELP

As already mentioned, specific online help for each LinkFax 8 function can be accessed from the **LinkFax 8** menu, and is indicated by a book icon (📖).

When you select a specific guide (e.g. **Fax Manager Guide**), the corresponding help window is displayed:

1

Double click on the item you wish to refer to (e.g. **How to use help**) and the corresponding help page will be displayed.

2

Follow the instructions given.

### WARNING

The **User Guide** (i.e. the **Instructions for Use** for all the LinkFax 8 functions available in the language selected during installation) can only be accessed **if the Acrobat Reader application is present**. If this application has not yet been installed, install it now following the instructions given in the guide.

## PRINTING THE USER GUIDE

You can print these instructions by selecting the **User Guide** item from the **LinkFax 8** menu. Double click on the **Print User Guide** item and follow the corresponding instructions.

### WARNING

The User Guide can only be printed **if the Acrobat Reader application is present**. If this application has not yet been installed,

install it now following the instructions given in the guide.

## CREATING 3.5" INSTALLATION DISKETTES

The installation CD can be copied onto **3.5" diskettes**. This makes it possible to install LinkFax 8 on PCs that are **not equipped with a CD ROM drive**.

**1**

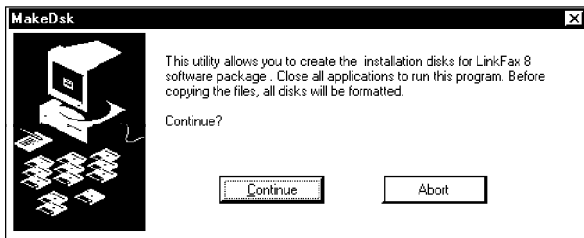
Power on the PC and wait for **Windows 95** to become active. Then insert the **CD in the CD ROM drive**.

**2**

From the **Start** menu, select **Run** and type **x:makedsk**, where **x** is the name of the CD ROM drive (for example, **d**). Click on **OK** to confirm:

**3**

Select your **mother language**, if it is not already selected and click on **OK** to confirm; an indication will be given of **how many diskettes** are required for the copying process:



**4**

Attach a **label** to the diskette, **with the corresponding number**, then place it in drive **A** and click on **OK** to confirm:

- if the diskette is **not a blank one**, the following message is displayed:

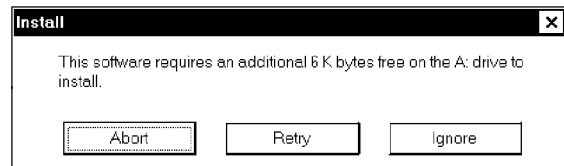


... asking you to confirm (**OK**) **formatting** of the diskette;

- if the diskette is **blank**, it is automatically formatted.

### WARNING

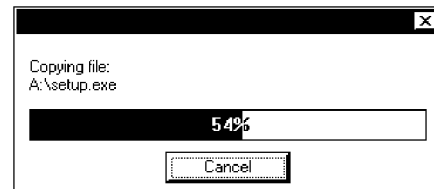
If, on completion of the formatting process, the following message is displayed:



... it means that the diskette is **damaged**: replace it with another diskette and click on **Retry**.

**5**

The copying process starts automatically, **copying files** from the CD to the diskette:



On completion of the copying process, you will be prompted to insert the next diskette: remove the first diskette from the drive and repeat steps **4** and **5**. When the last diskette has been copied, the following message is displayed:



... informing you that the diskette creation process is complete. Click on **OK** to confirm.

## INSTALLING LINKFAX 8 USING 3.5" DISKETTES

**1**

Power on the PC and wait for *Windows 95* to become active. Then insert the *first diskette into drive A*.

**2**

From the **Start** menu, select **Run** and type *a:setup*, then click on **OK** to confirm.

**3**

Continue by entering and confirming all the requested parameters (in the same way as during installation from CD), replacing the diskettes when prompted.

## INSTALLING AROBAT READER USING 3.5" DISKETTES

**1**

Power on the PC and wait for *Windows 95* to become active. Then insert the *penultimate diskette into drive A*.

**2**

From the **Start** menu, select **Run** and type *a:acoread*, then click on **OK** to confirm.

**3**

Follow the instructions as they appear and insert the *last diskette* into the drive when requested.

# 10. USER GUIDE OF THE LINKFAX 8 MODULE IN WINDOWS 95 ENVIRONMENT

## CONTENTS

---

<b>1 INTRODUCTION</b>	<b>2</b>	<b>5 SENDING AND RECEIVING VIA INTERNET</b>	<b>19</b>
NOTES ON THE USE OF THE COMMUNICATION PORT .....	2	SENDING VIA INTERNET .....	19
		Setting the Transmission Parameters .....	20
<b>2 USING THE FACSIMILE MACHINE AS A PRINTER</b>	<b>4</b>	RECEIVING VIA INTERNET .....	21
SELECTING THE PRINTER DRIVER .....	4	Setting the Reception Parameters .....	22
SETTING THE PRINTING PARAMETERS .....	4	Disabling Internet LinkFax Reception .....	22
PRINTING WITH LINKFAX 8 .....	7	<b>6 LINKFAX 8 ACCESSORY FUNCTIONS</b>	<b>23</b>
CHECKING THE PRINTER .....	8	FILE PROCESSING .....	23
		CREATING A NEW IMAGE .....	23
<b>3 USING THE FACSIMILE MACHINE AS A SCANNER</b>	<b>10</b>		
SCANNING USING THE SCANNER APPLICATION .....	10		
PROCESSING IMAGES .....	12		
SCANNING WITH TWAIN .....	14		
SCANNING WITH OLE .....	15		
<b>4 SENDING AND RECEIVING ON THE PC</b>	<b>17</b>		
INSTALLING MICROSOFT FAX .....	17		
ACTIVATING MICROSOFT FAX .....	17		
SENDING WITH THE PC .....	17		
RECEIVING WITH THE PC .....	18		

# 1 INTRODUCTION

**LinkFax 8** is a software communication module that transforms bubble ink jet facsimile machines into *multifunctional products* running under **Windows 95**.

In fact, once they have been *connected to a Personal Computer*, they may be used above all as a *graphic printer*. Documents such as letters, drawings or spreadsheets prepared using standard **Windows** applications may therefore be *printed by the facsimile machine*.

Alternatively, they may be used as a *scanner* for acquiring images and documents on the PC. This is made possible by the TWAIN module, which supplies the standard protocol between the facsimile machine and most popular image processing applications.

Again, with the aid of a fax application (for example, the Windows 95 Microsoft Fax), all kinds of documents (texts and images) *can be sent directly from the PC*. In addition, incoming fax messages can be *stored on the PC*, and subsequently displayed and processed using standard **Windows** applications.

Finally they permit transmission and reception of faxes as *E-mail attachments* using the **Internet** channel.

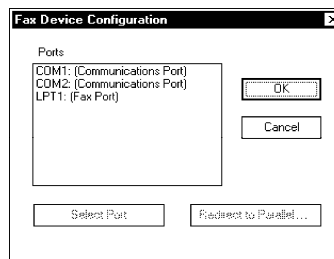
This guide contains instructions on how to use the various functions of **LinkFax 8**. These instructions are available both *on-line* (specific Guide) and in *printable format* (User Guide).

## NOTES ON THE USE OF THE COMMUNICATION PORT

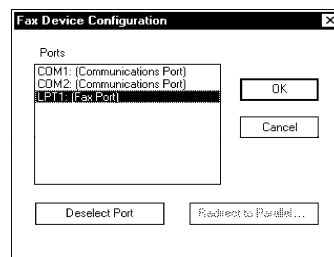
When the LinkFax 8 module is installed, the PC port to which the facsimile machine is connected will be *exclusively dedicated to the management of bubble ink jet facsimile machines* (Fax Port) supported by the module.

Should you need to use this port for devices other than facsimile machines, you can *temporarily deselect* the port and then reselect it:

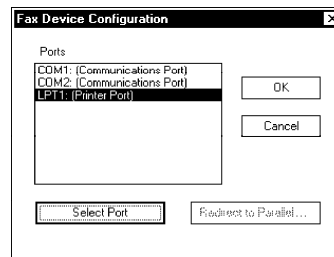
- Double click on the Fax Manager icon:



- Select the *fax port* (in the example **LPT1**):



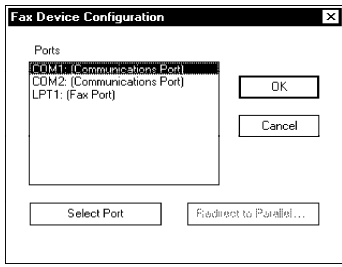
- Confirm the **Deselect port** button to enable the port for *standard operation* (Printer Port):



- To reselect the Fax Port, you will have to confirm the **Select Port** button.

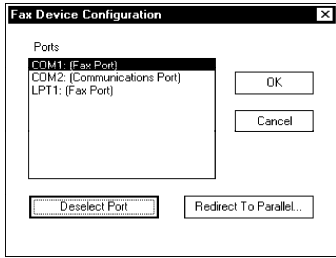
If you have to use an application that can only control the facsimile machine via a *serial port*, you can *temporarily redirect the serial port to the parallel port*. In this way, the application will "think" that it is using a serial port while in reality the facsimile machine is controlled via the parallel port.

- Double click on the Fax Manager icon and select the relevant *serial port* (in the example, **COM1**):



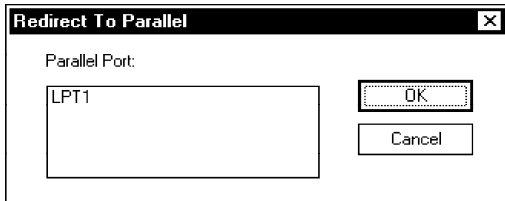
- Complete the procedure by confirming (**OK**).
- To restore standard port management, you must confirm the **Unredirect** button.

- Confirm the **Select Port** button:

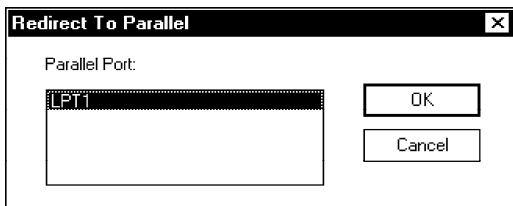


The **Redirect to Parallel** button will become active.

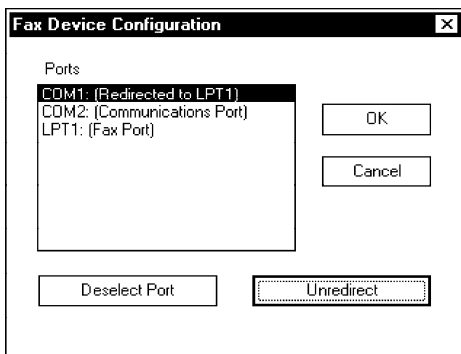
- Confirm the **Redirect to Parallel** button:



- Select the **parallel port** to which you wish to redirect the serial port (in the example, **LPT1**):



and click on **OK** to confirm:





## 2 USING THE FACSIMILE MACHINE AS A PRINTER

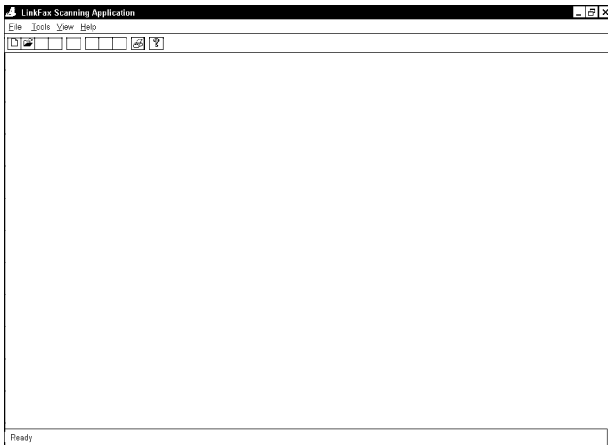
Once the *Printer driver* of the LinkFax 8 module has been installed (**LinkFax 8 Colour Printer**), the facsimile machine automatically becomes the *default printer*.

### SELECTING THE PRINTER DRIVER

To select the LinkFax 8 printer driver, proceed as follows:

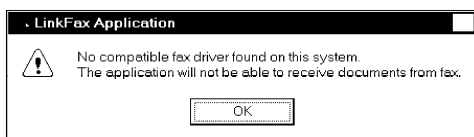
**1**

Select **Scanner Application** from the **LinkFax 8** menu on the **Programs** menu:



### WARNING

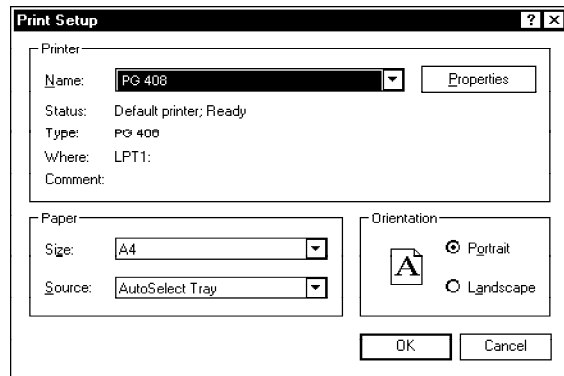
If the connection port of the PC port (Fax Port) has not been enabled, the following message is displayed:



In this case, select the port (see section entitled **Notes on the Use of the Communication Port** in Chapter 1) and then continue.

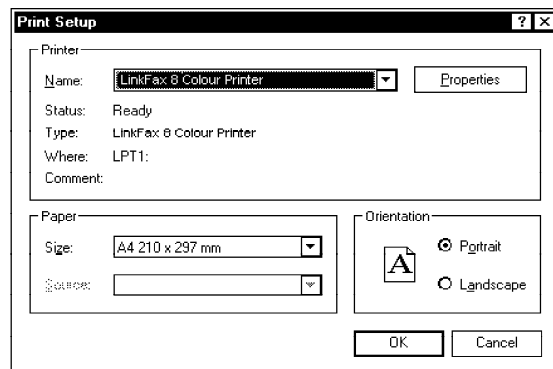
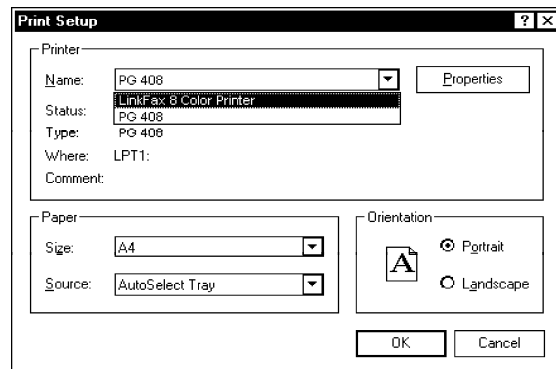
**2**

Select **Printer Setup** from the **File** menu:



**3**

Select **LinkFax 8 Colour Printer** from the **Name** list:



and click on **OK** to confirm.

### SETTING THE PRINTING PARAMETERS

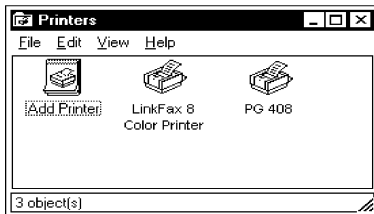
Once the **LinkFax 8 Colour Printer** has been installed, you can set the *printing parameters*

for the images or documents that you wish to print from the application of your choice.

The driver **Properties** can be accessed either via the **Status Monitor** (see section entitled **Checking the Printer**), or by following the instructions set out below:

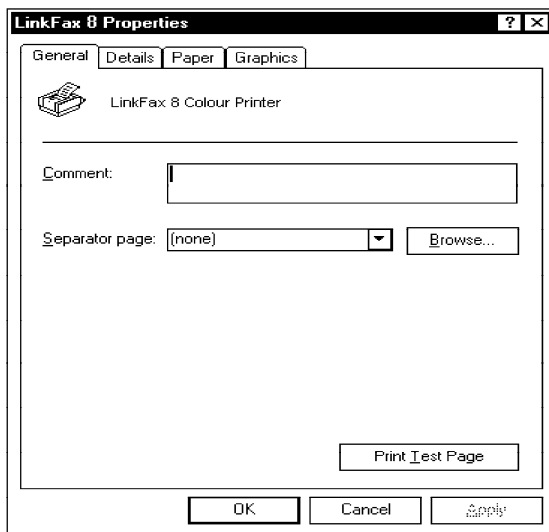
**1**

Select **Printers** from the **Settings** menu on the **Start** menu:



**2**

Click on the **LinkFax 8 Colour Printer** icon with the **right mouse button** and select **Properties**:

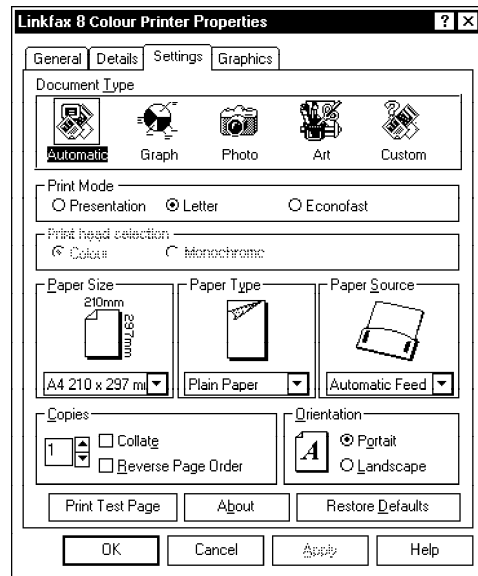


**3**

Set the Windows 95 **standard parameters** by selecting the **General** and **Details** boxes.

**4**

Select the **Settings** box:



... and select:

- **Document Type:**
  - **Automatic**, to set up **automatic detection** of the document to be printed: **black and white**, **colour**, or **mixed** (part black and white and part colour);
  - **Graph**, to print documents created using **computer graphics**;
  - **Photo**, to print **photographic images**;
  - **Art**, to print **drawings**;
  - **Custom**, to print special documents **created by you**.
- **Print Mode**, to set the best conditions for the type of image to be printed:
  - **Presentation**, to print **high definition images** (e.g. photographs, histograms, slides, etc.) and **quality black/white texts**;
  - **Letter**, to print **text** or **standard graphics**;
  - **Econofast**, to print **drafts**.
- **Print head selection**, to set the type of **print head**:
  - **Colour**
  - **Monochrome**.

**WARNING**

This parameter will be **disabled** if the document type selected is anything other than **Automatic**.

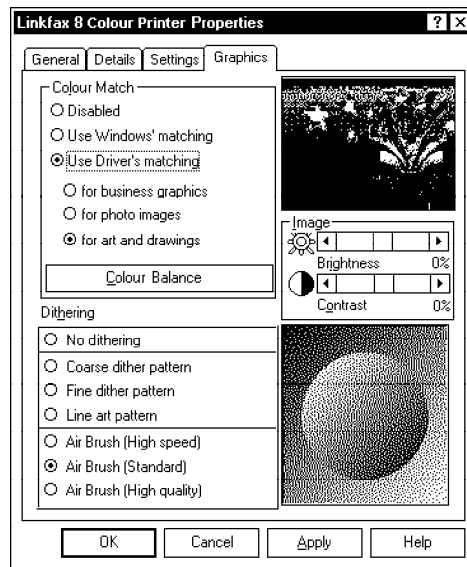
- **Paper Size**, to set the **size** of the paper being used by the facsimile machine: **A4, Letter, Legal**.
- **Paper Type**, to set the type of paper being used by the facsimile machine: **Plain Paper, Transparency Film (with backing), Transparency Film with Border, Glossy Paper, Coated Paper, Thick Paper**.
- **Paper Source**, to set the way in which the paper is to be fed into the facsimile machine:
  - **Automatic Feed**, if the paper in the paper tray can be easily fed into the facsimile machine: this can apply to both **plain paper** and special paper (**glossy, coated** and **transparency film**);
  - **Manual Feed**, if the paper to be used is **not easily fed** into the facsimile machine (e.g. it is too thick, too heavy or too smooth), or in the case of **transparency film with border** and **thick paper**.
  - **Orientation**, to set the page orientation for the image to be printed (**Vertical** or **Horizontal**).
- **Copies**, to select the number of copies to be printed of the document and the **order** in which the pages are to be printed: **Collate (increasing order)**, or **Reverse Page Order (decreasing order)**.

**WARNING**

Since the facsimile machine has **no resident character sets (FONTS)**, you can only use the characters offered by the application in use. For this reason, it is recommended that you use **True Type** characters (those preceded by the **T** symbol) to ensure that they are printed correctly.

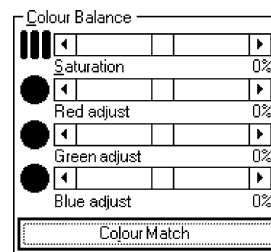
**5**

Click on the **Graphics** box if you wish to print a complex photographic image:

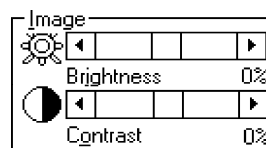


... and select:

- **Colour Match**, to improve colour **reproduction on paper**. This so-called **balancing** operation is necessary because the screen's chromatic definition is much higher than the print definition.
  - **Disabled**, to maintain the **original colours** of the image to be printed;
  - **Use Windows' matching**, to match the colours using the Windows method;
  - **Use Driver's matching**, to match the colours using the method operated by the **LinkFax 8 Colour Printer**.
- **Colour Balance**, to balance the colours of the image to be printed **manually**. In this case, the **colour selectors** will appear on top of the colour match section:

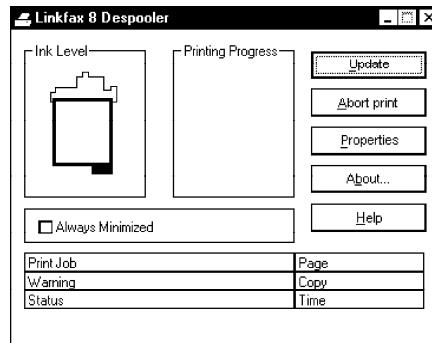
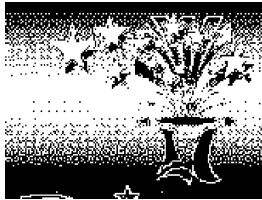


- **Brightness and Contrast of the Image:**



**WARNING**

Once the relevant parameters have been set, the image will appear in colour at the top right of the screen.



To complete the setup, select:

- **Dithering:** the resulting image will appear at the bottom right of the screen.

- **No dithering**



- **Coarse dither pattern**



- **Fine dither pattern**



- **Line Art pattern**



- **Air Brush (High Speed)**



- **Air Brush (Standard)**



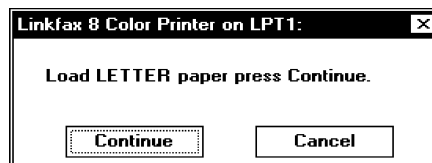
- **Air Brush (High Quality)**



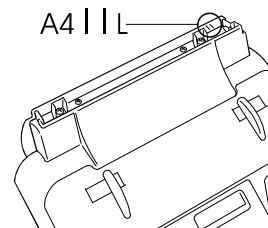
... containing standard Windows data: **Printing Progress** of the current document, name of the **document being printed (Print Job)**, current **Page, Copy** number and **Time** elapsed. The Status Monitor dialogue box remains active for the duration of the printing process and printing can be **interrupted** at any time by clicking on **Abort Print**.

**WARNING**

- If you set **manual feed**, **remove the paper tray** from the facsimile machine and then start the print: The following message will appear after the Status Monitor:



... prompting you to insert **one sheet of paper**, which must be aligned with the reference marks that correspond to the paper format (**A4** or **Letter**):

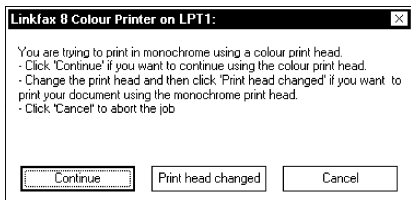


Once the paper has been inserted, printing begins in the normal way. If there is **more than one page** to be printed, you are prompted to insert another sheet of paper each time a page has been printed.

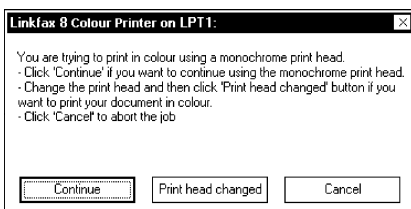
**PRINTING WITH LINKFAX 8**

After installing the **LinkFax 8 Colour Printer**, select it from the application in which you want to work. The facsimile machine will be activated and the relative dialogue box (**Status Monitor**) is displayed on the PC monitor:

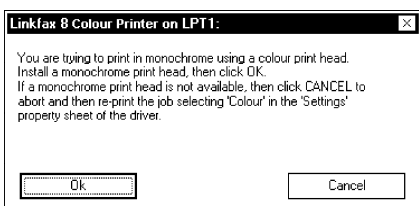
- If **Document & Type** is set to **Automatic** and it **does not correspond to the type of print head** installed, you will be prompted to replace the print head:



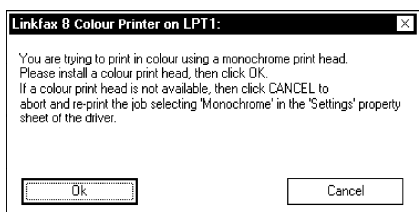
OR:



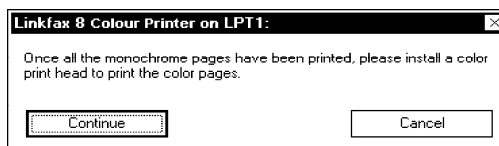
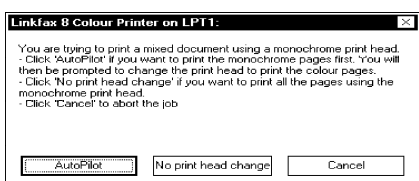
- If the type of document set is **not Automatic** and the print head selected is **different to the one installed**, you will be prompted to change the print head:



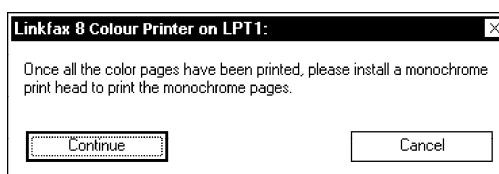
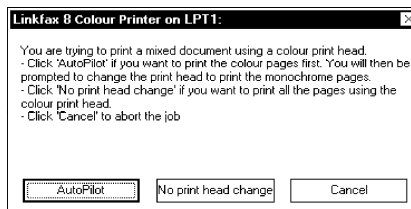
OR:



- If **Document & Type** is set to **Automatic** and you are printing a **mixed** document, instructions on how to begin printing are displayed:



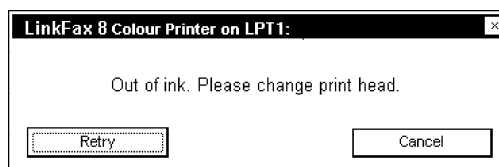
OR:



- When the print head is finished, the following message appears:

#### OUT OF INK

If a **refillable** print head is in use, the following message appears on the PC monitor:



## CHECKING THE PRINTER

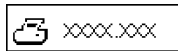
You can **only** check the status and configuration of the printer **before starting or on completion of the print process**.

Select **Printer** from the **LinkFax 8** menu on the **Programs** menu, then select the **Status Monitor**; the corresponding dialogue box is displayed, allowing you to check the following:

- the **Ink Level** of the print head: click on **Update** and the level (or three levels in the case of a colour print head) is highlighted on the print head image;

- the **printer setting**: click on **Properties** and the dialogue box associated to the properties of the **LinkFax 8 Colour Printer** driver is displayed.

You can **reduce** the Status Monitor dialogue box (which remains active for the duration of the printing process) to an **icon**. To do this, click on **Always minimized** and it will appear at the bottom of the screen as an icon when the next print process is activated.



... where **xxxx.xxx** indicates the name of the **file being printed**.

# 11. INSTALLATION OF THE LINKFAX 8 MODULE IN WINDOWS 3.1x ENVIRONMENT

## CONTENTS

---

<b>1 INTRODUCTION</b>	<b>2</b>
SYSTEM REQUIREMENTS .....	2
CONNECTING THE FACSIMILE MACHINE TO THE PC .....	2
PRINT HEAD PRECAUTIONS .....	3
<b>2 INSTALLING THE LINKFAX 8 MODULE</b>	<b>4</b>
UPDATING THE LINKFAX 8 MODULE .....	6
UNINSTALLING THE LINKFAX 8 MODULE .....	6
ACCESSING ONLINE HELP .....	7
PRINTING THE USER GUIDE .....	7

# 1 INTRODUCTION

**LinkFax 8** is a software communication module that transforms bubble ink jet facsimile machines into **multifunctional products** running under **Windows 3.1x**.

In fact, once they have been **connected to a Personal Computer**, they may be used above all as a **graphic printer**. Documents such as letters, drawings or spreadsheets prepared using standard **Windows** applications may therefore be **printed by the facsimile machine**.

Alternatively, they may be used as a **scanner** for acquiring documents on the PC.

Finally, with the aid of the **WinFAX** application (manufactured by **Delrina** in Canada), documents can be **transmitted directly from the PC**. Incoming faxes can also be **stored on the PC** and then displayed and processed using standard **Windows** applications.

This guide describes how to install the LinkFax 8 module in Windows 3.1x. The LinkFax 8 module is supplied on **Compact Disk** and comes with the following:

- this **"Installation"** guide
- one **parallel cable**
- one **print head container**.

Instructions on how to use the various functions of **LinkFax 8** are available both **on-line** (specific Guide) and in **printable format** (User Guide).

## SYSTEM REQUIREMENTS

The communication software of the **LinkFax 8** module can only be installed on an **IBM-compatible** PC with the following **recommended minimum configuration** (the minimum configuration supported is shown in brackets):

- processor **486** (386)
- RAM **8 Mbytes** or more (4 Mbytes)
- monitor **VGA** or higher
- MS-DOS version **5.00** or higher
- Windows version **3.11**

(3.1 advanced procedures)

- **CD ROM** drive.

### WARNING

To install the **WinFAX** application, you must **first install the LinkFax 8 module** and have **enough free space on the hard disk**. The amount of space required depends on the type of installation that you wish to carry out (i.e. maximum, minimum, or personalised) and is indicated in the documentation associated with the application.

During installation of the WinFAX application, you must check that the **type of modem is CAS** (and change the setting, if necessary).

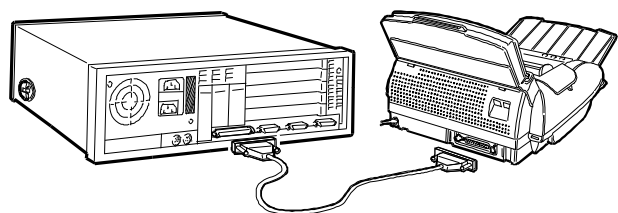
Furthermore, since your facsimile machine **automatically inserts a heading** for each document sent, make sure that **a second heading is not added** by the WinFAX application. To do this you should either **avoid entering a heading** when prompted to do so, or **cancel the heading** proposed by the application, depending on the version of WinFAX to be installed.

### IMPORTANT

On completion of the WinFAX installation procedure, make sure that there **are at least 1.5 Megabytes of free space on the hard disk**. You must also have at least this amount of free space **when using the LinkFax 8 module**.

## CONNECTING THE FACSIMILE MACHINE TO THE PC

The facsimile is connected to the PC by means of the **parallel cable**, as shown below:





**WARNING**

The **protection cover must be removed** before the parallel port of the facsimile can be accessed.

## PRINT HEAD PRECAUTIONS

The bubble ink jet facsimile machine uses both monochrome (black) and colour print heads:

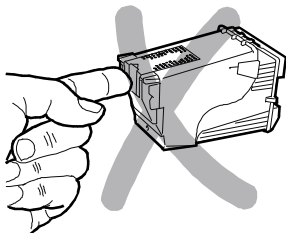
- **monochrome**, for use with the **facsimile**, or the **printer** in **black and white** mode;
- **colour**, for use with the **printer** in **colour** mode.

**WARNING**

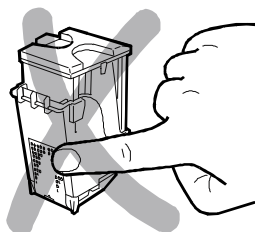
When the colour print head is installed, the documents received will **not be printed straight away**, but stored in the memory of the facsimile machine. Once the memory is full, the facsimile will no longer be able to receive documents, so **always remember** to replace the monochrome print head each time the facsimile is reset.

Since it will be necessary to change the print head regularly, depending on what the facsimile is to be used for, take note of the following precautions:

- **do not touch, or stand** the print head on the **ink jets**:

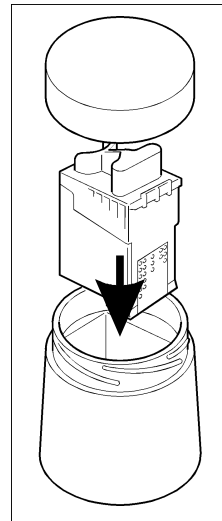


... or the **contacts**:



- **never try to re-load** the print head, as this could damage the print head or the facsimile;

- always place the **print head not in use** in the special container:



This will ensure long life and efficiency of the print head and a high print quality.

- Try **not to get ink on hands or clothes**, as it is very difficult to remove.

### VERY IMPORTANT

The facsimile machine automatically recognises the type of print head installed and checks the level of ink remaining by means of a special internal counter. When there is no ink remaining, the message **OUT OF INK** appears on its display.

In order for the ink level monitored by the internal counter to be consistent with the actual level contained the print head, **never install the print heads of one facsimile machine onto another facsimile machine or bubble ink jet printer**.

## 2 INSTALLING THE LINKFAX 8 MODULE

The **LinkFax 8** communication module consists of *two main components*, which can be selected individually:

- 1 **Utility module:** acquires black and white images via the facsimile machine (*scanning*), irrespective of the application that will be used to process them. It also *enables the PC to send and receive*.

### WARNING

- The utility module *does not allow* documents to be sent and received. These functions are performed by the **WinFax** application, which must be installed after the utility module.
- The scanned documents can be stored in **DCS, PCX, BMP** and **TIF** formats and are handled directly by standard **Windows** applications, or they can be made available to the **WinFax** environment.

- 2 **Printer driver:** handles the facsimile machine as a *graphic printer*, with a maximum resolution of 300 dots per inch.

The Compact Disk supplied with the kit also contains the installation program. This program guides you through a series of dialog boxes to enable you to install what you require onto the hard disk of your PC.

### WARNING

The following general conditions apply to the dialog boxes that appear during the installation procedure:

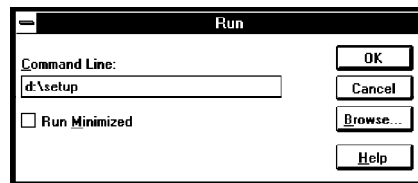
- *optional elements* can only be *selected using the mouse*;
- *buttons* can be *selected* either using the mouse, or by pressing the  $\rightarrow$  and  $\otimes$  arrow keys;
- the *selected button* can be confirmed using the *mouse*, or by pressing the **Enter** key.

1

Power on the PC, wait for **Windows 3.1x** to start and then insert the **CD in the CD ROM drive** (e.g. **d:**).

2

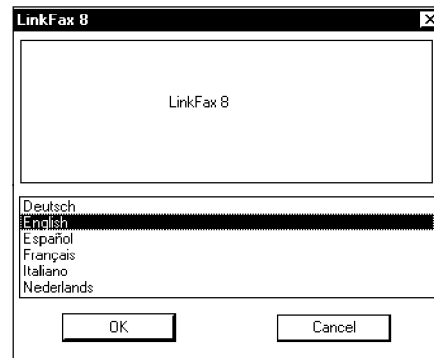
Select **Run** from the **File** menu of **Program Manager** and type **x:setup**, where **x** is the name of the drive (for example, **d**).



... then click on **OK** to confirm.

3

Select your *mother language* ...



... and click on **OK** to confirm. A welcome message appears explaining how to continue (**Continue**), or abort the installation procedure (**Exit**):



### WARNING

You can abort the installation procedure from any of the dialog boxes that appear from now on. If you decide to abort the procedure, the program will prompt for confirmation (**Yes**):



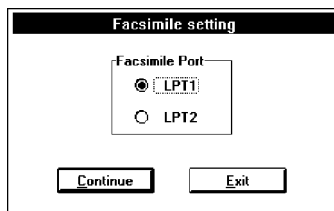
and then return to Windows 3.1x:



If you abort the installation procedure, *none* of the items selected *will be installed*.

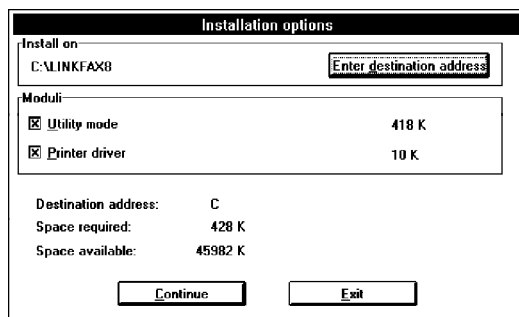
**4**

Select the **port** to which the facsimile machine has been connected:



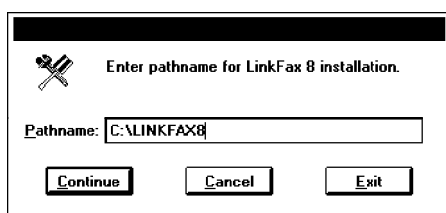
**5**

Select the **components** you wish to install:



**6**

If you do not wish to change the predefined installation path (**c:\linkfax8**), click on **Continue** to confirm and go straight to step 8. Otherwise, click on **Enter destination address**:

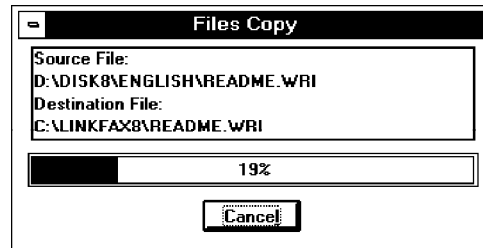


**7**

Type the new path and click on **Continue** to confirm: the dialog box described in step 5 is displayed again with the new path to be confirmed.

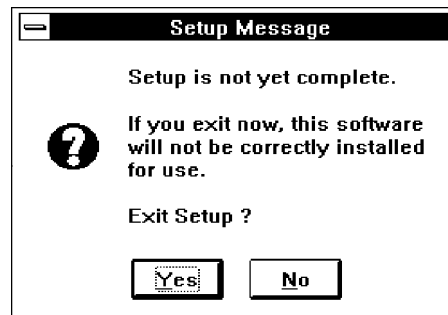
**8**

A dialog box enables you to keep track (in %) of the files being installed from the CD to the hard disk:



### WARNING

If you click on **Cancel** while the files are being loaded, this will interrupt the installation procedure:



Click on **Yes** to confirm:



... then click on **OK**.

9

On completion of the installation procedure, a dialog box prompting you to restart the system appears:



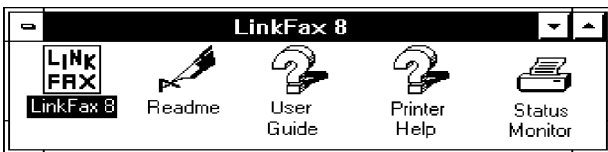
Click on **OK** to confirm; the system is restarted automatically.

If you have installed the **Utility module**, the **LinkFax group 8** icon appears automatically when Windows 3.1x is restarted.



10

Double click on the group icon to check that it has been installed correctly:



## UPDATING THE LINKFAX 8 MODULE

Having performed the initial installation of the LinkFax 8 module, you may need to carry out one of the following procedures:

- **Adding components** to a previous partial installation: repeat the installation procedure by selecting the required elements.
- **Updating the current version** of the module: perform the installation procedure, re-selecting the required components and applications. During installation, any elements that were not included in the previous version will be **added** and the existing elements will be **updated**.

## WARNING

If, during installation, you select the same destination path used for the previous installation, the new version of the **LinkFax 8** module will overwrite the old one. If, on the other hand, you select a different destination path, you will have two versions of the module installed

## UNINSTALLING THE LINKFAX 8 MODULE

### IMPORTANT

The LinkFax 8 module can **only be uninstalled manually, by deleting files and directories from the hard disk**. Since this operation requires a certain degree of experience, **make sure that a competent member of staff is present**.

1

Double click on **File Manager**, select the **Windows\System** directory and double click on **sysedit.exe**. All the relevant Windows files are opened, one on top of the other.

2

If the file on top is not **Autoexec.bat**, or **Win.ini**, close it by double clicking on the box in the left hand corner and continue to close the rest of the files until you come to the two files in question.

3

Delete:

- the **call c:\casloc.bat** item from the **Autoexec.bat** file.
- The **[LinkFax 8]** group (i.e. all the items listed in it) from the **Win.ini** file.

Following each deletion, click on **Save** on the **File** menu and then **close** the file.

On completion of the two deletions, click on **Exit** on the **File** menu to return to **File Manger**.

4

Select the main directory (**c:**) and delete the **casloc.bat** and **casloc.bak** files.

5

Delete the **c:\casdir** directory together with the directory where the LinkFax 8 module is installed

(*c:\linkfax8*, or whatever name was assigned during installation).

**6**

Delete the following files from the *c:\windows\system* directory:

<i>lfctrl.dll</i>	<i>lfrsc3.dll</i>
<i>lfdsplr3.exe</i>	<i>lfspmng3.exe</i>
<i>lfimage.bmp</i>	<i>linkfx.drv</i>
<i>lfjnllb3.dll</i>	<i>linkfxln.dll</i>
<i>lfprsht.dll</i>	<i>ofiooss16.dll</i>
<i>lfrastr3.dll</i>	<i>prn_drv.hlp</i>

**7**

Double click on the **Control panel** icon and then double click on the **Printers** icon and cancel the **LinkFax 8 Color Printer** item from the **Installed Printers** list.

**8**

Click on the **LinkFax 8** group icon and then click outside the corresponding dialog box to close it. Press the **DEL** key and click on **Yes** to confirm deletion of the icon.

## ACCESSING ONLINE HELP

As already mentioned, specific online help for each LinkFax 8 function can be accessed via icons in the **LinkFax 8** window.

When you select a specific guide by double-clicking on the associated icon (e.g. **Printer Help**), the corresponding help window is displayed:

**1**

Double click on the item you wish to refer to (e.g. **How to use help**) and the corresponding help page will be displayed.

**2**

Follow the instructions given in the guide.

### WARNING

The **User Guide** (i.e. the *Instructions for Use* for all the LinkFax 8 functions available in the language selected during installation) can only be accessed *if the Acrobat Reader application is present*. If this application has not yet been installed, install it now following the instructions given in the guide.

## PRINTING THE USER GUIDE

You can print these instructions by selecting the **User Guide** item from the **LinkFax 8** menu, followed by the instructions for using the LinkFax 8 module. Double click on the **User Guide** icon on the **LinkFax** menu, then double click on the **Print User Guide** item and follow the corresponding instructions.

### WARNING

The User Guide can only be printed *if the Acrobat Reader application is present*. If this application has not yet been installed, install it now following the instructions given in the guide.

# 12. USER GUIDE OF THE LINKFAX 8 MODULE IN WINDOWS 3.1x ENVIRONMENT

## CONTENTS

---

<b>1 INTRODUCTION</b>	<b>2</b>
<b>2 USING THE FACSIMILE MACHINE AS A PRINTER</b>	<b>3</b>
SELECTING THE PRINTER DRIVER .....	3
SETTING THE PRINTING PARAMETERS .....	3
PRINTING WITH LINKFAX 8 .....	5
CHECKING THE PRINTER .....	6
<b>3 USING THE FACSIMILE MACHINE AS A SCANNER</b>	<b>8</b>
SETTING THE PC TO USE THE FACSIMILE MACHINE AS A SCANNER .....	8
SCANNING WITH THE FACSIMILE MACHINE .....	8
Scan to File .....	9
Scan to Fax Manager .....	9
Interrupting the Scanning Process .....	9
<b>4 SENDING AND RECEIVING DOCUMENTS</b>	<b>10</b>
SENDING A DOCUMENT .....	10
RECEIVING A DOCUMENT .....	10

# 1 INTRODUCTION

---

**LinkFax 8** is a software communication module that transforms bubble ink jet facsimile machines into **multifunctional products** running under **Windows 3.1x**.

In fact, once they have been **connected to a Personal Computer**, they may be used above all as a **graphic printer**. Documents such as letters, drawings or spreadsheets prepared using standard **Windows** applications may therefore be **printed by the facsimile machine**.

Alternatively, they may be used as a **scanner** for acquiring images and documents on the PC.

Finally, with the aid of the **WinFAX** application (manufactured by **Delrina** in Canada), documents can be **transmitted directly from the PC**. Incoming faxes can also be **stored on the PC** and then displayed and processed using standard **Windows** applications.

This guide describes how to use the various **LinkFax 8** functions. These instructions are available both online (specific Guide) and in **printable format** (User Guide).

## 2 USING THE FACSIMILE MACHINE AS A PRINTER

Once the **Printer driver** of the LinkFax 8 module has been installed (**LinkFax 8 Colour Printer**), the facsimile machine automatically becomes the **default printer**.

### SELECTING THE PRINTER DRIVER

To select the LinkFax 8 printer driver, proceed as follows:

**1**

Double click on the **Control Panel** icon and then double click on the **Printers** icon.

**2**

Select **LinkFax 8 Colour Printer** from the list of **Installed Printers**, then:

- click on **Set as Default Printer** to setup the facsimile machine as the **default printer**, therefore taking priority over any other printers installed;
- if you wish to **optimise the sharing of resources**, disable the **Use Print Manager** function, by clicking on the appropriate box until **the cross disappears**.

**3**

Click on **Connect** and select the name of the **parallel port of the PC (LPT1 or LPT2)** to which the facsimile machine is connected. Then:

- if you wish to **optimise the printing speed** of the facsimile machine, check that the **Fast Printing Direct to Port** function is enabled by clicking on the appropriate box until the **cross appears**. Then **disable automatic reception**, as described in the section entitled **Receiving a Document**.

**4**

Click on **OK** to confirm and then click on **Close**, to close the **Printers** dialogue box.

### SETTING THE PRINTING PARAMETERS

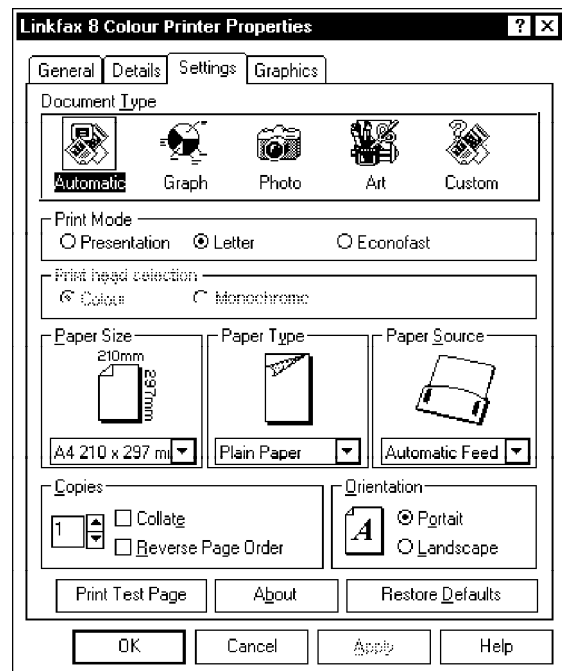
Once the **LinkFax 8 Colour Printer** has been installed, you can set the **printing parameters**

for the images or documents that you wish to print from the application of your choice.

The driver **Properties** can be accessed either via the **Status Monitor** (see section entitled **Checking the Printer**), or by following the instructions set out below:

**1**

Select **Print Setup** from the **File** menu and enter the basic printing parameters: page **Orientation** (portrait or landscape), **Paper size**, paper **Feed** (manual or automatic). Then click on **Options**:



... and select the following:

- **Document Type:**
  - **Automatic**, to set up **automatic detection** of the document to be printed: **black and white**, **colour**, or **mixed** (part black and white and part colour);
  - **Graph**, to print documents created using **computer graphics**;
  - **Photo**, to print **photographic images**;
  - **Art**, to print **drawings**;
  - **Custom**, to print special documents **created by you**.



- **Print Mode**, to set the best conditions for the type of image to be printed:
  - **Presentation**, to print **high definition images** (e.g. photographs, histograms, slides, etc.) and **quality black/white texts**;
  - **Letter**, to print **text** or **standard graphics**;
  - **Econofast**, to print **drafts**.
- **Print head selection**, to set the type of **print head**:
  - **Colour**;
  - **Monochrome**.

**WARNING**

This parameter will be **disabled** if the document type selected is anything other than **Automatic**.

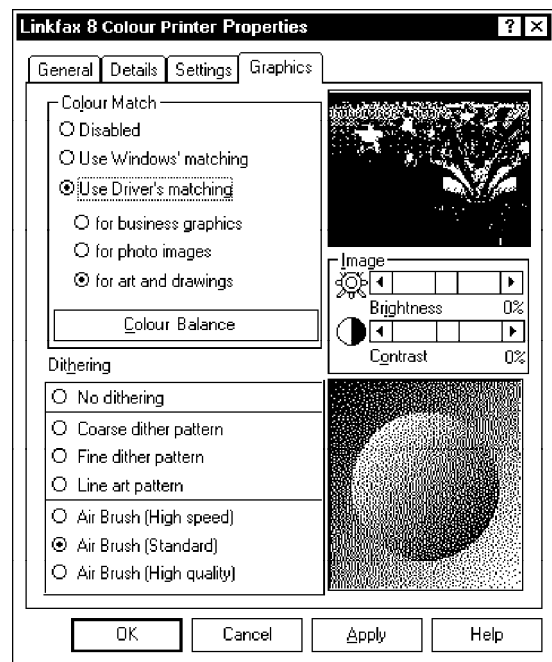
- **Paper Size**, to set the **size** of the paper being used by the facsimile machine: **A4**, **Letter**, **Legal**.
- **Paper Type**, to set the **type** of paper being used by the facsimile machine: **Plain Paper**, **Transparency Film** (with backing), **Transparency Film with Border**, **Glossy Paper**, **Coated Paper**, **Thick Paper**.
- **Paper Source**, to set the way in which the paper is to be fed into the facsimile machine:
  - **Automatic Feed**, if the paper in the paper tray can be easily fed into the facsimile machine: this can apply to both **plain paper** and special paper (**glossy**, **coated** and **transparency film**);
  - **Manual Feed**, if the paper to be used is not **easily fed** into the facsimile machine (e.g. it is too thick, too heavy or too smooth), or in the case of **transparency film with border** and **thick paper**.
  - **Orientation**, to set the page orientation for the image to be printed (**Vertical** or **Horizontal**).
- **Copies**, to select the number of copies to be printed of the document and the **order** in which the pages are to be printed: **Collate** (**increasing** order), or **Reverse Page Order** (**decreasing** order).

**WARNING**

Since the facsimile machine has **no resident character sets (FONTS)**, you can only use the characters offered by the application in use. For this reason, it is recommended that you use **True Type** characters (those preceded by the **T** symbol) to ensure that they are printed correctly.

**2**

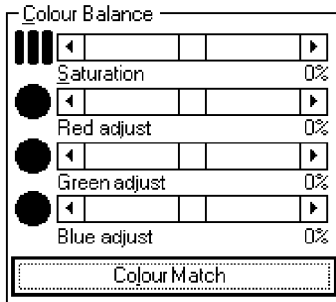
Click on the **Graphics** box if you wish to print a complex photographic image:



... and select:

- **Colour Match**, to improve colour **reproduction on paper**. This so-called **balancing** operation is necessary because the screen's chromatic definition is much higher than the print definition.
  - **Disabled**, to maintain the **original colours** of the image to be printed;
  - **Use Windows' matching**, to match the colours using the Windows method;
  - **Use Driver's matching**, to match the colours using the method operated by the **LinkFax 8 Colour Printer**.
- **Colour Balance**, to balance the colours of the image to be printed **manually**. In this case, the **colour selectors** will appear on top of the

colour match section:

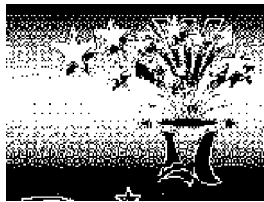


- **Brightness and Contrast of the Image:**



**WARNING**

Once the relevant parameters have been set, the image will appear in colour at the top right of the screen.



To complete the setup, select:

- **Dithering:** the resulting image will appear in colour at the bottom right of the screen.

- **No dithering**



- **Coarse dither pattern**



- **Fine dither pattern**



- **Line art pattern**



- **Air Brush (High speed)**



- **Air Brush (Standard)**

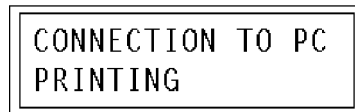


- **Air Brush (High quality)**

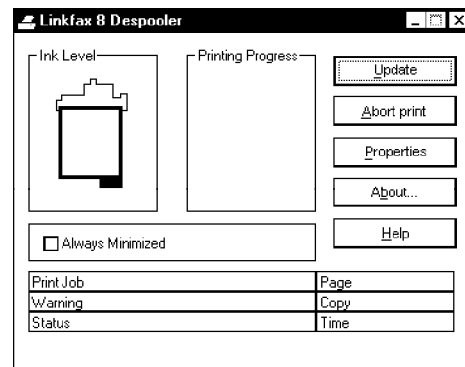


**PRINTING WITH LINKFAX 8**

After installing the **LinkFax 8 Colour Printer**, select it from the application in which you want to work. The facsimile machine will be activated and the following message appears on the facsimile display:



... and the relative dialogue box (**Status Monitor**) is displayed on the PC monitor:



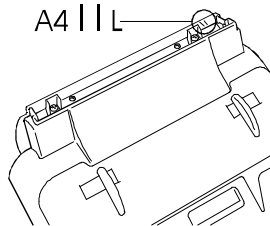
... containing standard Windows data: **Printing Progress** of the current document, name of the **document being printed (Print Job)**, current **Page**, **Copy** number and **Time** elapsed. The Status Monitor dialogue box remains active for the duration of the printing process and printing can be **interrupted** at any time by clicking on **Cancel Printing**.

**WARNING**

- If you activated the **Use Print Manager** function and you wish to interrupt the current print job, press the **STOP** button on the facsimile machine and then **cancel** the document being printed by **Print Manager**.
- If you set **manual feed**, **remove the paper tray** from the facsimile machine and then start the print: The following message will appear after the Status Monitor:

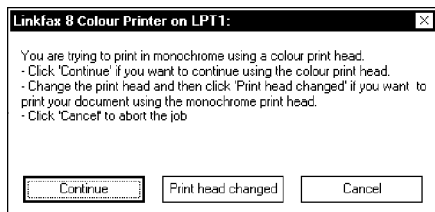


... prompting you to insert **one sheet of paper**, which must be aligned with the reference marks that correspond to the paper format (**A4** or **Letter**):

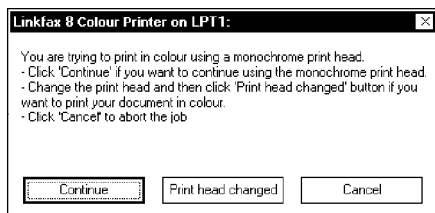


Once the paper has been inserted, printing begins in the normal way. If there is **more than one page** to be printed, you are prompted to insert another sheet of paper each time a page has been printed.

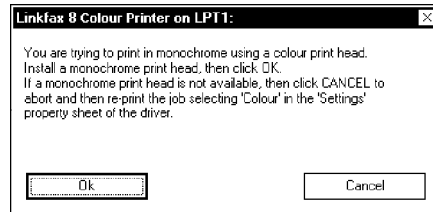
- If **Document & Type** is set to **Automatic** and it **does not correspond to the type of print head** installed, you will be prompted to replace the print head:



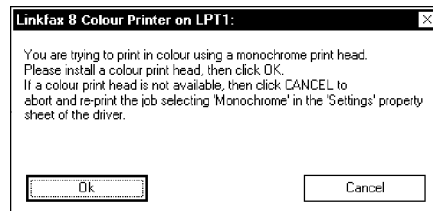
OR:



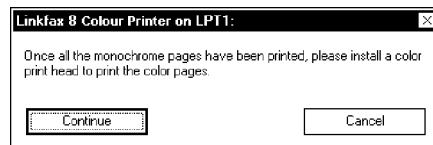
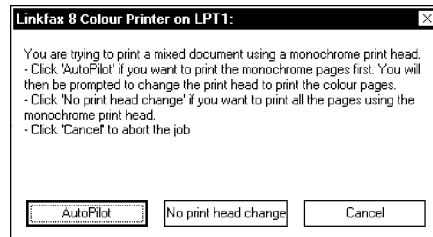
- If the type of document set is **not Automatic** and the print head selected is **different to the one installed**, you will be prompted to change the print head:



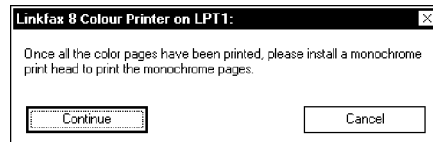
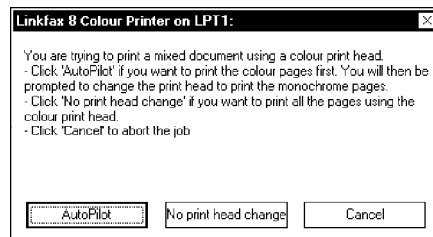
OR:



- If **Document & Type** is set to **Automatic** and you are printing a **mixed** document, instructions on how to begin printing are displayed:



OR:

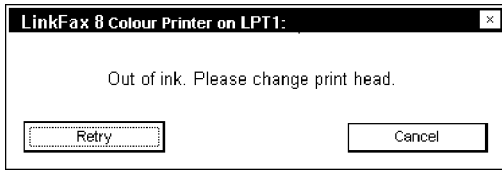


- When the print head is finished, the following message appears:

**OUT OF INK**

If a **refillable** print head is in use, the fol-

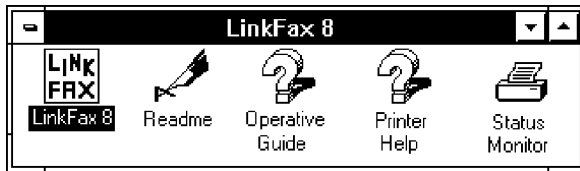
Following message appears on the PC monitor:



## CHECKING THE PRINTER

You can **only** check the status and configuration of the printer **before starting or on completion of the print process.**

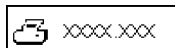
Double click on the **LinkFax 8** group icon:



... and double click on the **Status Monitor** icon: the corresponding dialogue box is displayed, allowing you to check the following:

- the **Ink Level** of the print head: click on **Refresh** and the level (or three levels in the case of a colour print head) is highlighted on the print head image;
- the **printer settings**: click on **Properties** and the dialogue box associated to the **Properties** of the **LinkFax 8 Colour Printer** is displayed.

You can **reduce** the Status Monitor dialogue box (which remains active for the duration of the printing process) to an **icon**. To do this, click on **Always minimized** and it will appear at the bottom of the screen as an icon when the next print process is activated.



... where **xxxx.xxx** indicates the name of the **file being printed.**

### 3 USING THE FACSIMILE MACHINE AS A SCANNER

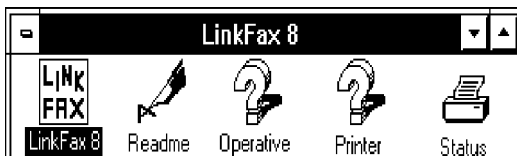
The **LinkFax 8** communication module makes it possible for the facsimile machine to be used as a **scanner** to scan in documents.

#### SETTING THE PC TO USE THE FACSIMILE MACHINE AS A SCANNER

In order for your facsimile machine to be used as a scanner, the parallel port of the PC must be setup as described below:

**1**

Double click on the **LinkFax 8** group icon:



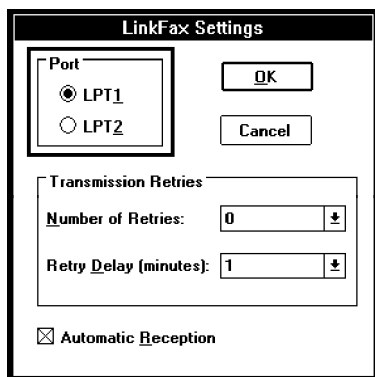
**2**

Double click on the **LinkFax 8** icon to enter the **communication environment**.



**3**

Click on the  icon:



**4**

Click on the name of the **PC port** (**LPT1** or **LPT2**) to which the facsimile is connected and click on **OK** to confirm.

#### SCANNING WITH THE FACSIMILE MACHINE

The **scanning** of a document using the facsimile machine is performed in the **communication** environment, whereas the document is **managed** in the **Windows** or **WinFax** environment.


**1**

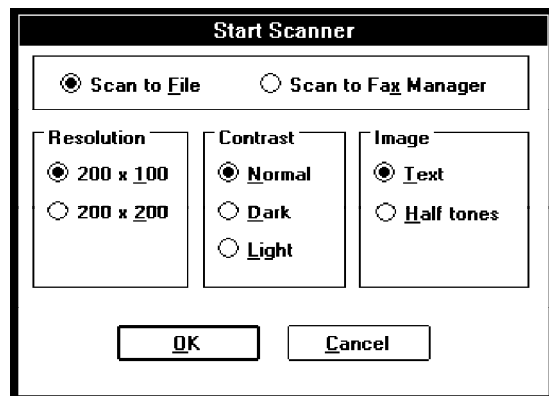
Place the document to be scanned onto the document feeder (make sure that the number of **pages does not exceed** the maximum number supported by the facsimile machine).

**2**

Move to the **communication environment**.



... and click on the  icon:



**3**

Set the **scanning parameters**:

- **Scan to File**, to assign a **name**, **format** and **destination file** to the acquired document;
- **Scan to Fax Manager**, with predefined name and format;
- **Contrast**: normal, dark, or light;
- **Resolution** in dpi (dots per inch): 200 x 100, or 200 x 200;
- **Image**: **Text** (line art), **Gray tones** (with **32 shades** of gray);

... and click on **OK** to confirm. The PC displays this message:



... and the facsimile machine displays this message:

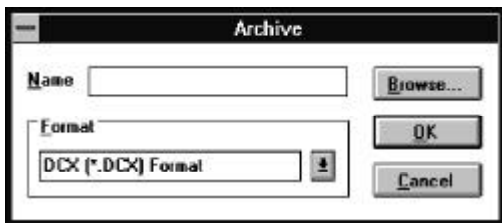


### WARNING

Contrast and resolution are the two factors that contribute to the sharpness and definition of the scanned image. The various settings should therefore be made in accordance with the characteristics of the image.

## Scan to File

The document is read by the facsimile machine and **sent to the PC**. On completion of the scanning process, the PC displays a dialogue box:



... where the characteristics of the **destination file** must be entered:

- **File name:** the **maximum number of characters** that can be assigned to a name, depending on the format the file is to be saved in:
  - **8 characters**, for **DCX** format, where **all the pages** of the scanned document are stored in a **unique file**;
  - **5 characters** for **BMP, PCX** or **TIF** formats, where **each page is stored in a separate file**. Each file will have the name you specified, plus a **progressive number** assigned

automatically, to make up the 8 characters (e.g. xxxxx001, xxxxx002, etc. or xxx00001, xxx00002, etc.)

- **Format:** the format in which the file is to be saved is **independent of the scanning resolution**;
- **Browse:** to select the **destination path**.

### WARNING

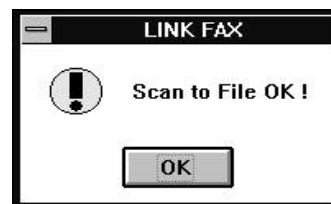
If no destination path is specified, the file will automatically be saved in the **c:\casdir** directory.

## Scan to Fax Manager

The document is read by the facsimile machine and **sent to the PC**. It is **automatically** stored by the PC and made **available to the WinFax environment**, that allows resolutions of 200 x 100 and 200 x 200. On completion of the scanning process, the following message is displayed confirming reception of the document:



Click on **OK**; the following message is displayed confirming that the document has been saved to file:



Click on **OK**; the acquired document can now be managed using your preferred application.

## Interrupting the Scanning Process

To interrupt the current scanning process, press the **STOP** button on the facsimile machine.

## 4 SENDING AND RECEIVING DOCUMENTS

For information on how to send and receive documents, refer to the documentation provided with the *WinFax* application.


### SENDING A DOCUMENT

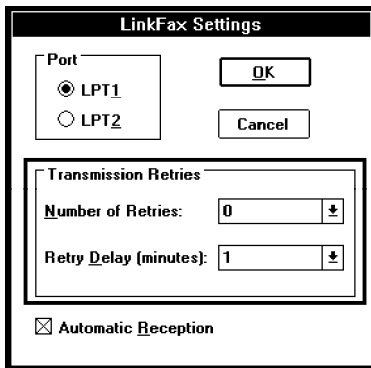
Before sending a document, you can set the following parameters:

**1**

Move to the *communication environment*.



... and click on the  icon:



**2**

Set the transmission parameters:

- **Number of retries:** click on the arrow to set the number of *times* you wish to remake the call, from **0** (no retry) to **5**;
- **Retry Delay:** click on the arrow to set the number of *minutes* (from 1 to 10) that are to lapse between one retry and the next;

... and click on **OK** to confirm; the facsimile machine displays the following message:



#### WARNING

- When dialling the *telephone number*, you can use the following (as on the facsimile

machine):

- the digits **0 to 9**
  - the **\*** and **#** characters
  - the letter **E**, to **connect to the public network** (when connected to a PBX)
  - the letter **p** (lower case) to insert a **pause between the digits**
  - the **:** character for the "**second tone**" feature.
- Since the facsimile machine **automatically assigns a header** to each document transmitted, **you must not assign another header** from the WinFax application. Likewise, (depending on the WinFax version installed on your PC), **do not type in the header** when prompted to do so; otherwise **delete the header** automatically proposed by the application.


### RECEIVING A DOCUMENT

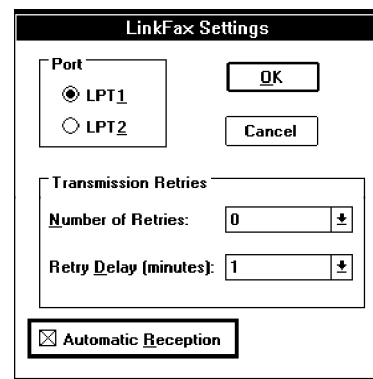
Before receiving a document, you can set the following parameters:

**1**

Move to the *communication environment*.

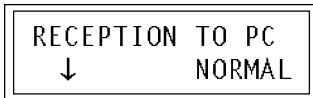


... and click on the  icon:



## 2

Set the *reception parameters*, in this case just the **Automatic Reception** parameter. Click on the box until the cross *appears* and click on **OK** to confirm; the facsimile machine displays the following message:



### WARNING

- If you wish to *disable reception on the PC*, click on the box until the cross *disappears*.
- If you wish to *receive simultaneously on the facsimile* and the PC, refer to the **Instructions for Use** of the facsimile machine and set the **RX ON PC & FAX** parameter in the *Operating configuration*.



# 13. SPARES LISTINGS

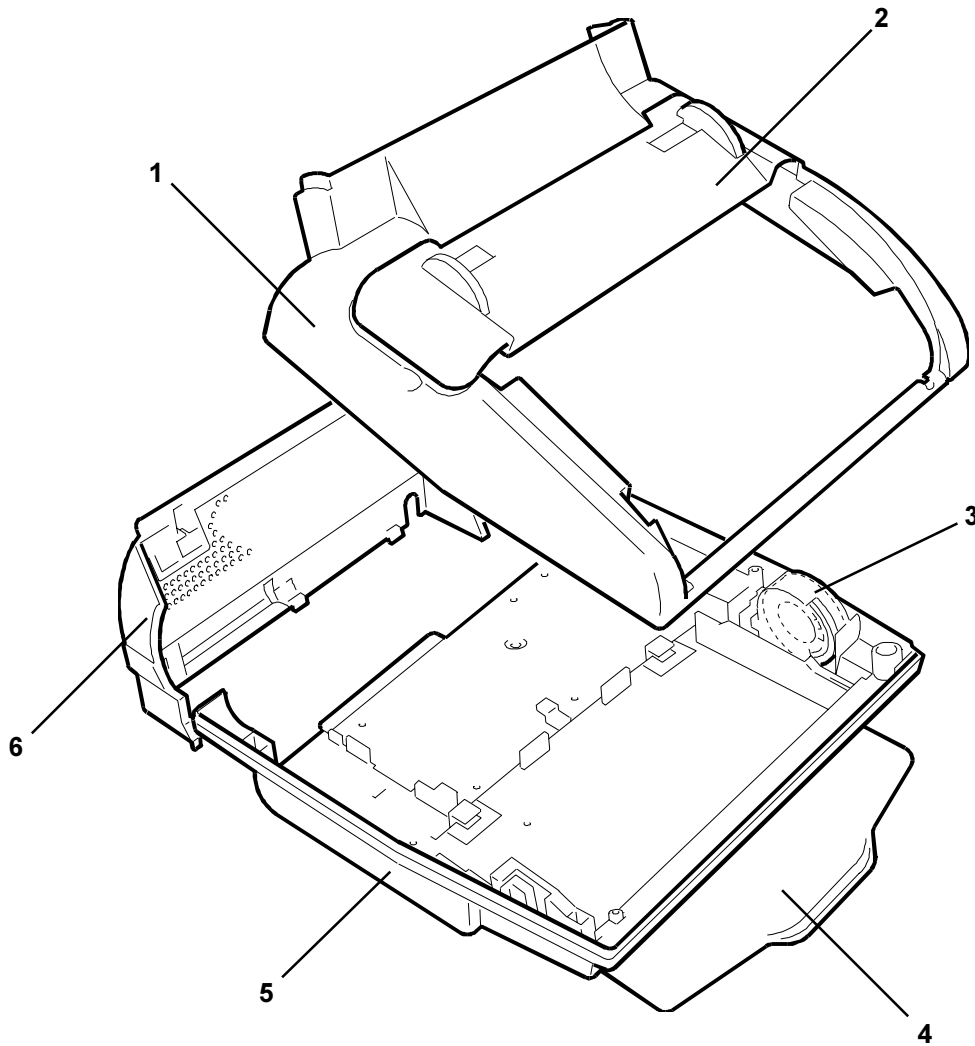
## CONTENTS

COVERS .....	Page	2
PAPER SUPPORT AND PAPER CASSETTE ASSEMBLY .....	"	3
KEYBOARD ASSEMBLY .....	"	4
SENSOR AND OPTICAL ASSEMBLY .....	"	5
SCANNER ASSEMBLY .....	"	6
PUMP AND PAPER FEEDER ASSEMBLY .....	"	7
CARRIAGE ASSEMBLY .....	"	8
PAPER FEEDER DFC165 .....	"	9
PAPER FEEDER DWC165c .....	"	10
POWER SUPPLY AND NCU BOARD .....	"	11
BOARDS .....	"	12
<b>GENERAL CODES INDEX .....</b>	<b>"</b>	<b>13</b>

# COVERS

DFC165  
DWC165c

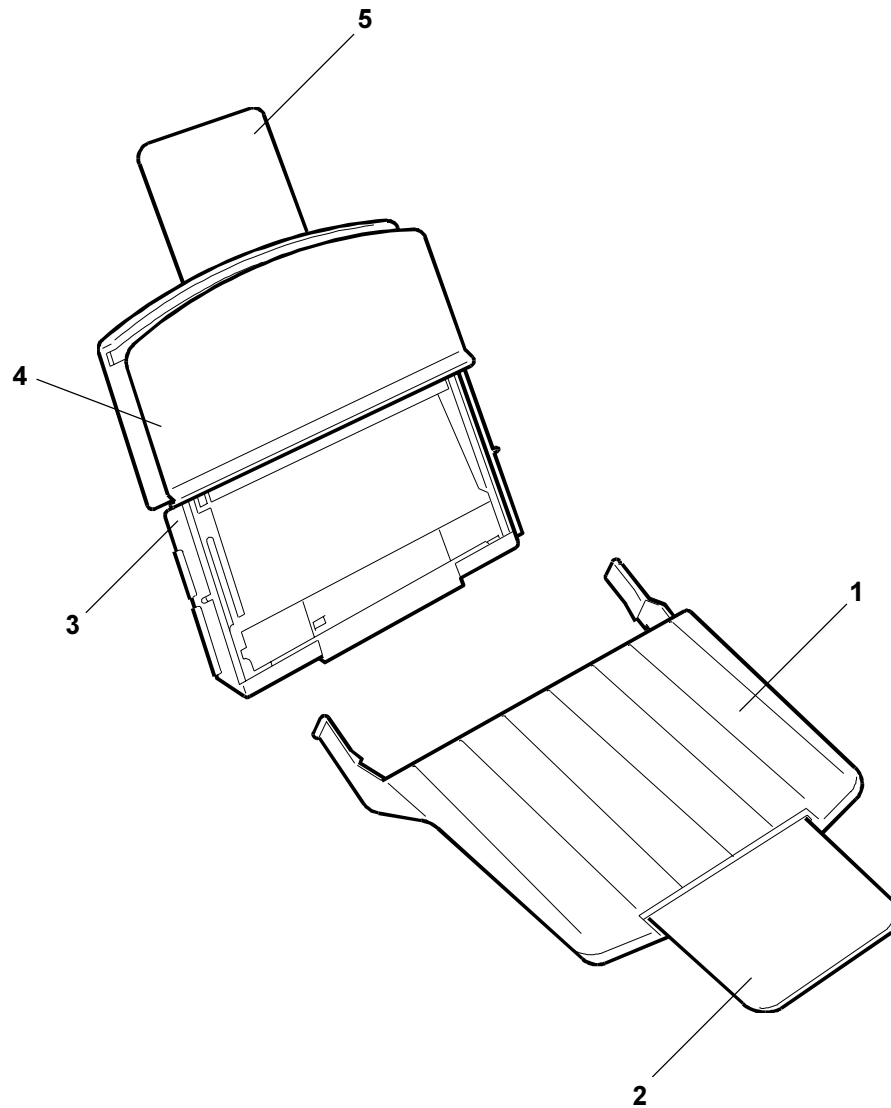
REF.	CODE	DESCRIPTION
1	002N01516	UPPER COVER
2	002N01517	HEAD COVER ASSEMBLY
3	130N00822	SPEAKER ASSEMBLY
4	030N00387	LOWER PAPER SUPPORT
5	002N01518	BOTTOM COVER
6	002N01519	REAR COVER



# PAPER SUPPORT AND PAPER CASSETTE ASSEMBLY

DFC165  
DWC165c

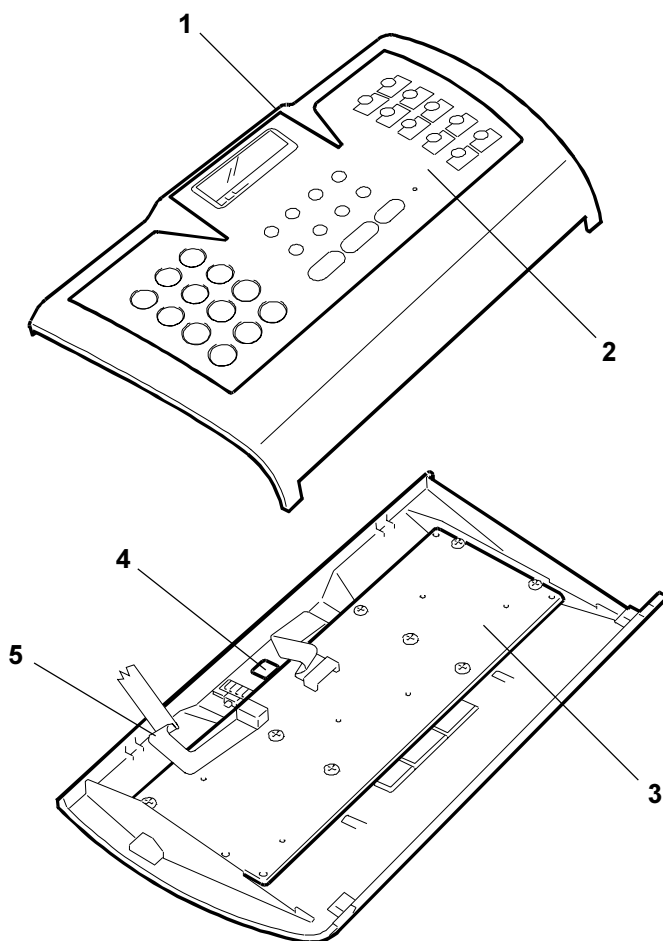
REF.	CODE	DESCRIPTION
1	030N00391	UPPER PAPER SUPPORT
2	030N00390	PAPER SUPPORT EXTENSION
3	-	CASSETTE ASSEMBLY
4	002N01520	PAPER COMPARTMENT COVER
5	038N00229	PAPER GUIDE



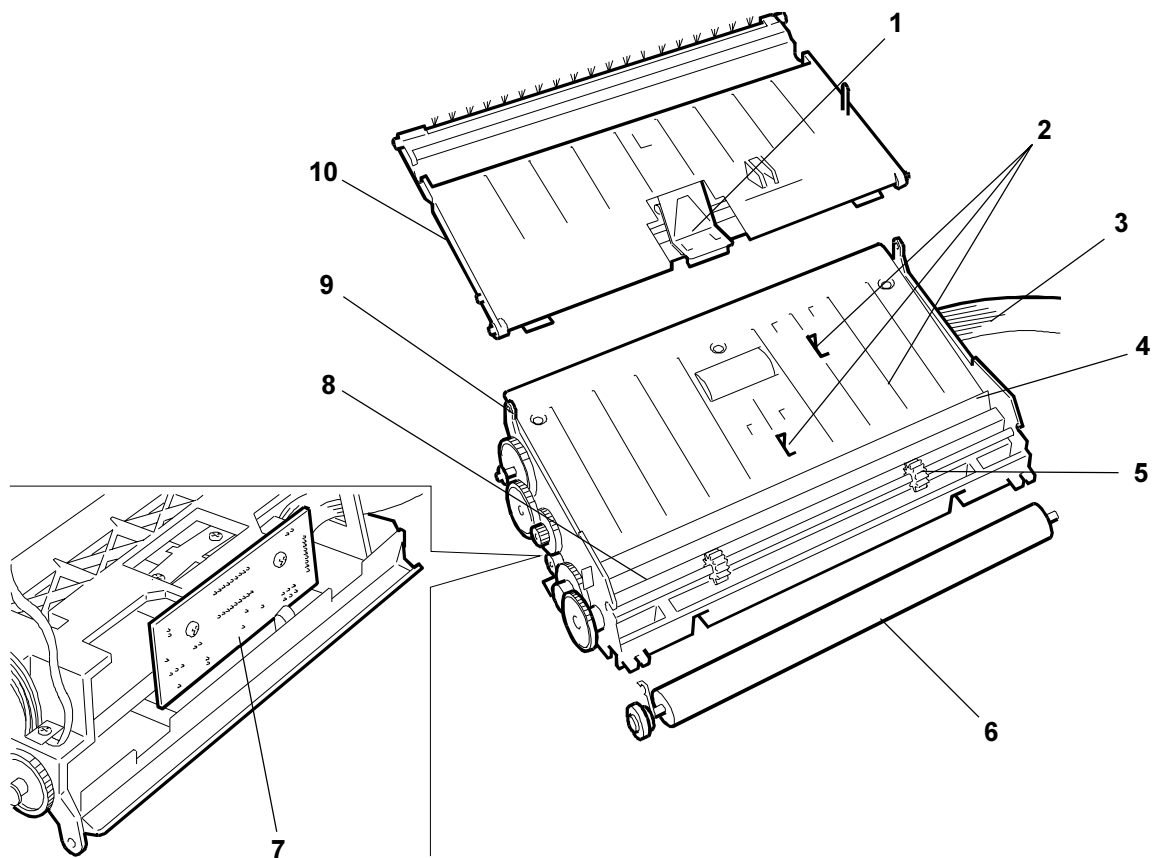
# KEYBOARDASSEMBLY

DFC165  
DWC165c

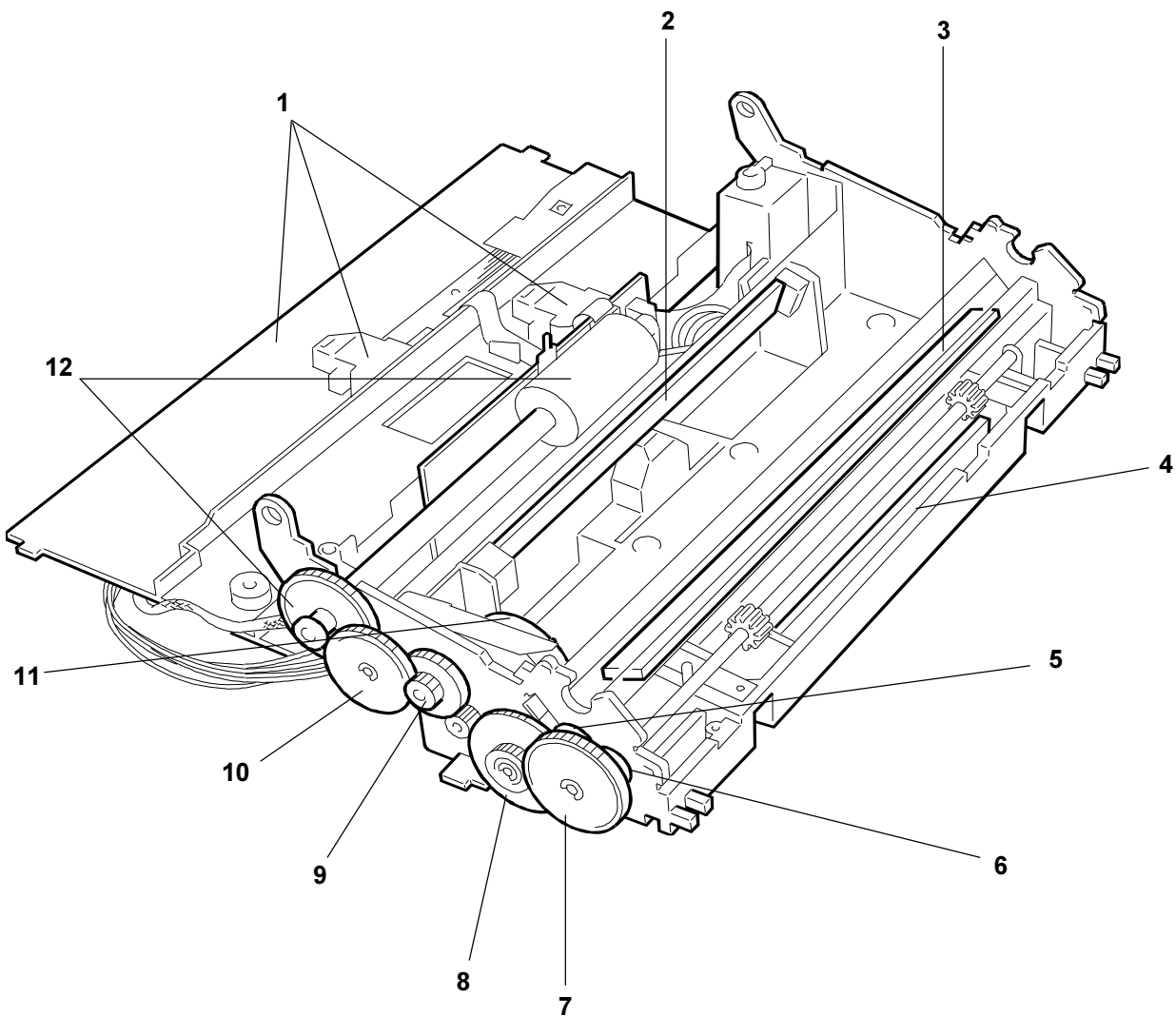
REF.	CODE	DESCRIPTION
1	110N00780	KEYBOARDASSEMBLY
2	-	KEYBOARD LABEL ITALY
	-	KEYBOARD LABEL GERMANY
	-	KEYBOARD LABEL U.K.
	-	KEYBOARD LABEL SPAIN
	-	KEYBOARD LABEL FRANCE
	-	KEYBOARD LABEL PORTUGAL
3	140N05083	KEYBOARD PCB
4	123N00175	DISPLAYASSEMBLY
5	152N01613	KEYBOARD FLAT CABLE



REF.	CODE	DESCRIPTION
	109N00386	SCANNER ASSEMBLY
1	002N01521	ADF ASSEMBLY
2	130N00815	ADF SENSOR UNIT AND CONVEYOR
3	152N01612	FLAT CCD CABLE
4	062N00138	GLASS
5	121N00397	ADF EJECTOR ROLLER GROUP
6	022N00908	ORIGINAL ROLLER ASSEMBLY
7	140N05093	CCD CARD
8	128N00425	LED ARRAY ASSEMBLY
9	130N00820	ADF LOCATOR
10	054N00037	PAPER CONVEYOR ASSEMBLY



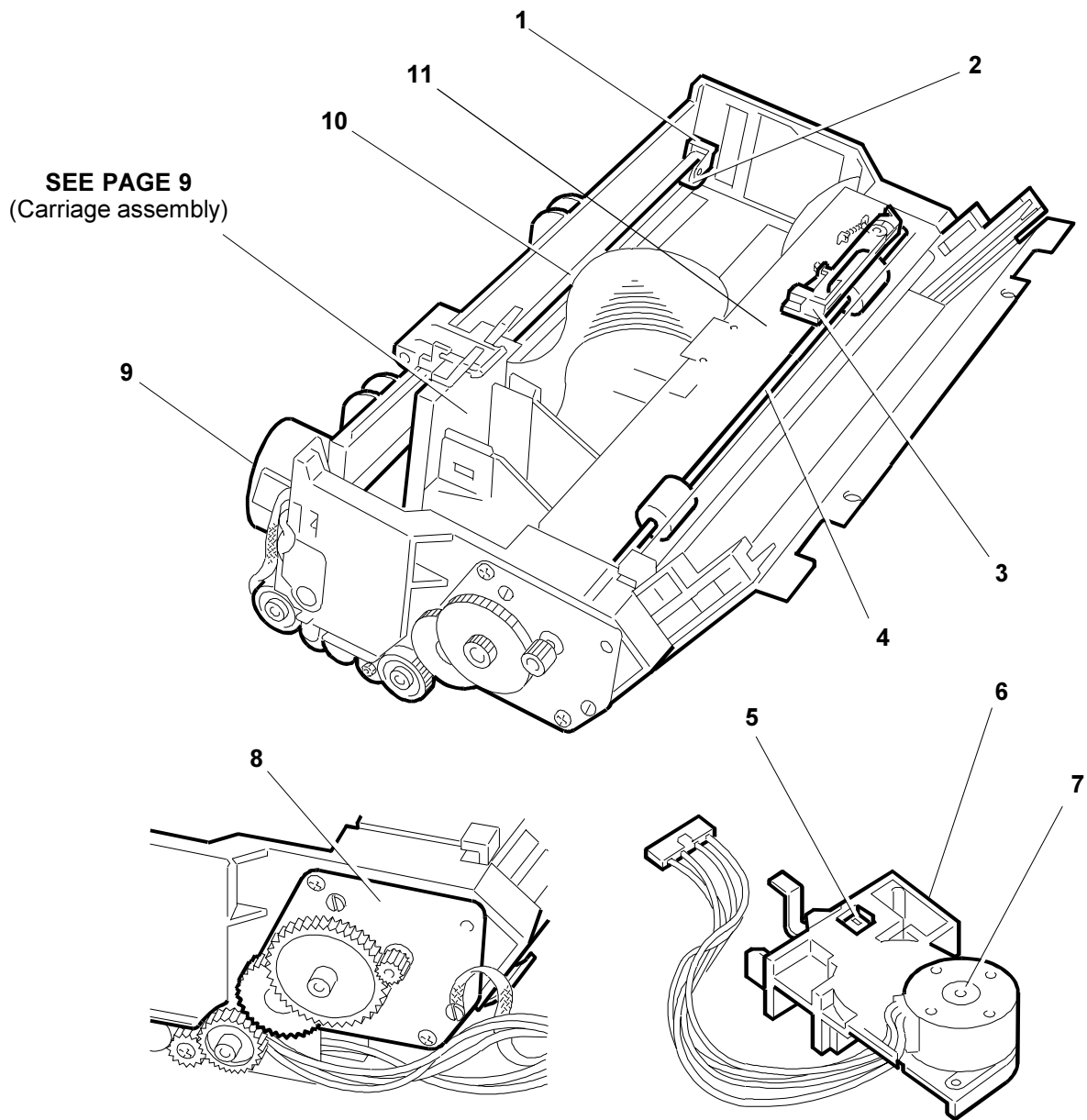
REF.	CODE	DESCRIPTION
1	130N00815	ADF SENSOR UNIT AND CONVEYOR
2	062N00135	MIRROR 2
3	062N00136	MIRROR 1
4	062N00137	MIRROR 3
5	007N00682	GEAR T=20
6	007N00684	PAPER OUTPUT ROLLER GEAR
7	007N00685	GEAR T=60/16
8	007N00686	GEAR T=59/25
9	007N00687	GEAR T=42/16
10	007N00689	GEAR T=50/16
11	127N00967	ADF MOTOR ASSEMBLY
12	022N00909	ADF ROLLER ASSEMBLY



# PUMP AND PAPER FEEDER ASSEMBLY

DFC165  
DWC165c

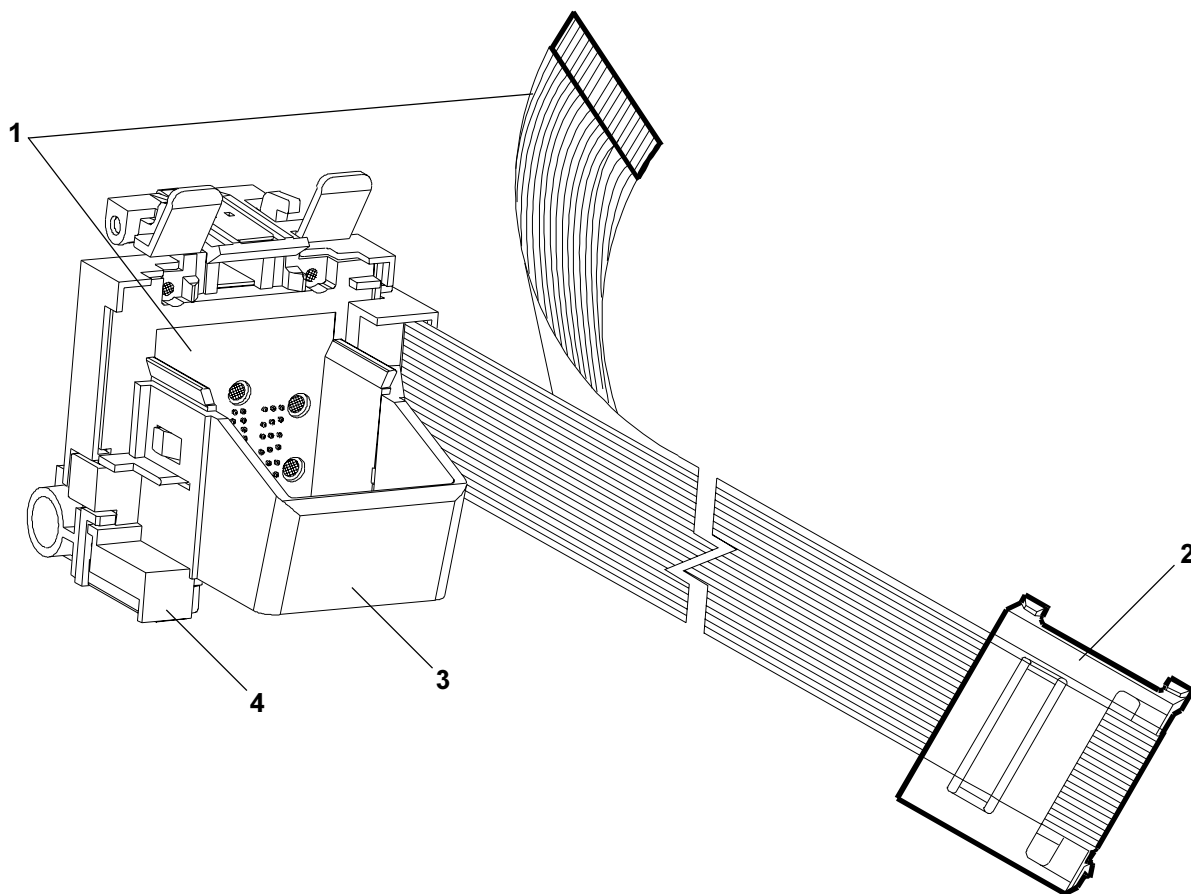
REF.	CODE	DESCRIPTION
1	020N00436	BELT TIGHTENER
2	020N00437	BELT TIGHTENER PULLEY
3	110N00782	MICROSWITCH ASSEMBLY WITH CABLE
4	006N00878	ASF SHAFT ASSEMBLY
5	094N00201 019N00408	ASPIRATION RUBBER ASSY (DFC165) ASPIRAT. RUBBER ASSY(DWC165c)
6	127N00968 127N00964	PUMP ASSEMBLY (DFC165) PUMP ASSEMBLY (DWC165c)
7	127N00962	PUMP MOTOR
8	127N00967 127N00963	PAPER FEED MOTOR ASSY (DFC165) PAP. FEED MOTOR ASSY (DWC165c)
9	127N00960	CARRIAGE MOTOR
10	023N00585	CARRIAGE BELT
11	-	PAPER ROLLER ASSEMBLY



# CARRIAGE ASSEMBLY

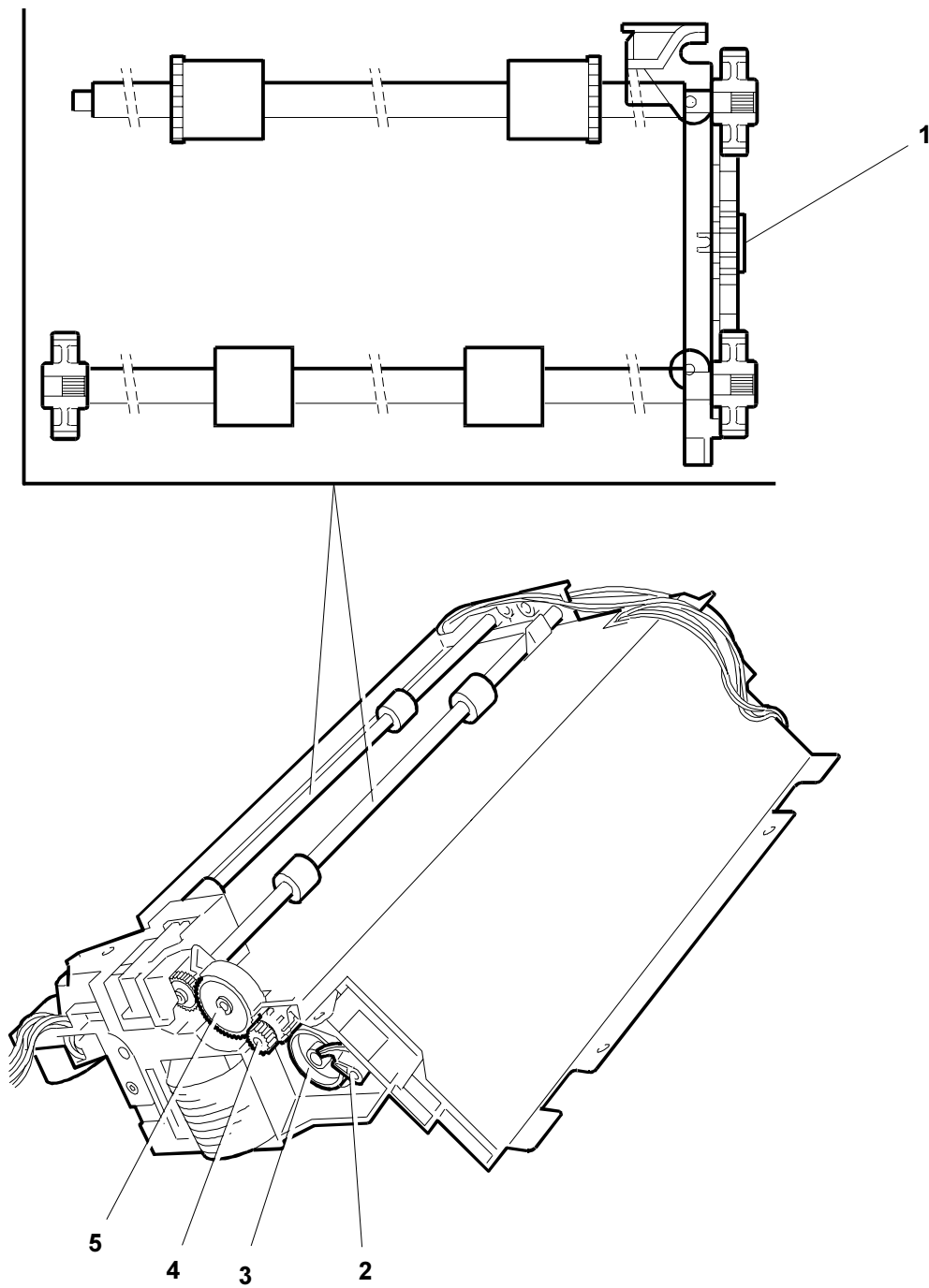
DFC165  
DWC165c

REF.	CODE	DESCRIPTION
1	041N00819	CARRIAGE GROUP WIT FLAT 24 WAY
2	041N00188	CARRIAGE FLAT SUPPORT
3	032N00208	HEAD GUIDE
4	130N00821	PAPER SENSOR FLAT ASSEMBLY

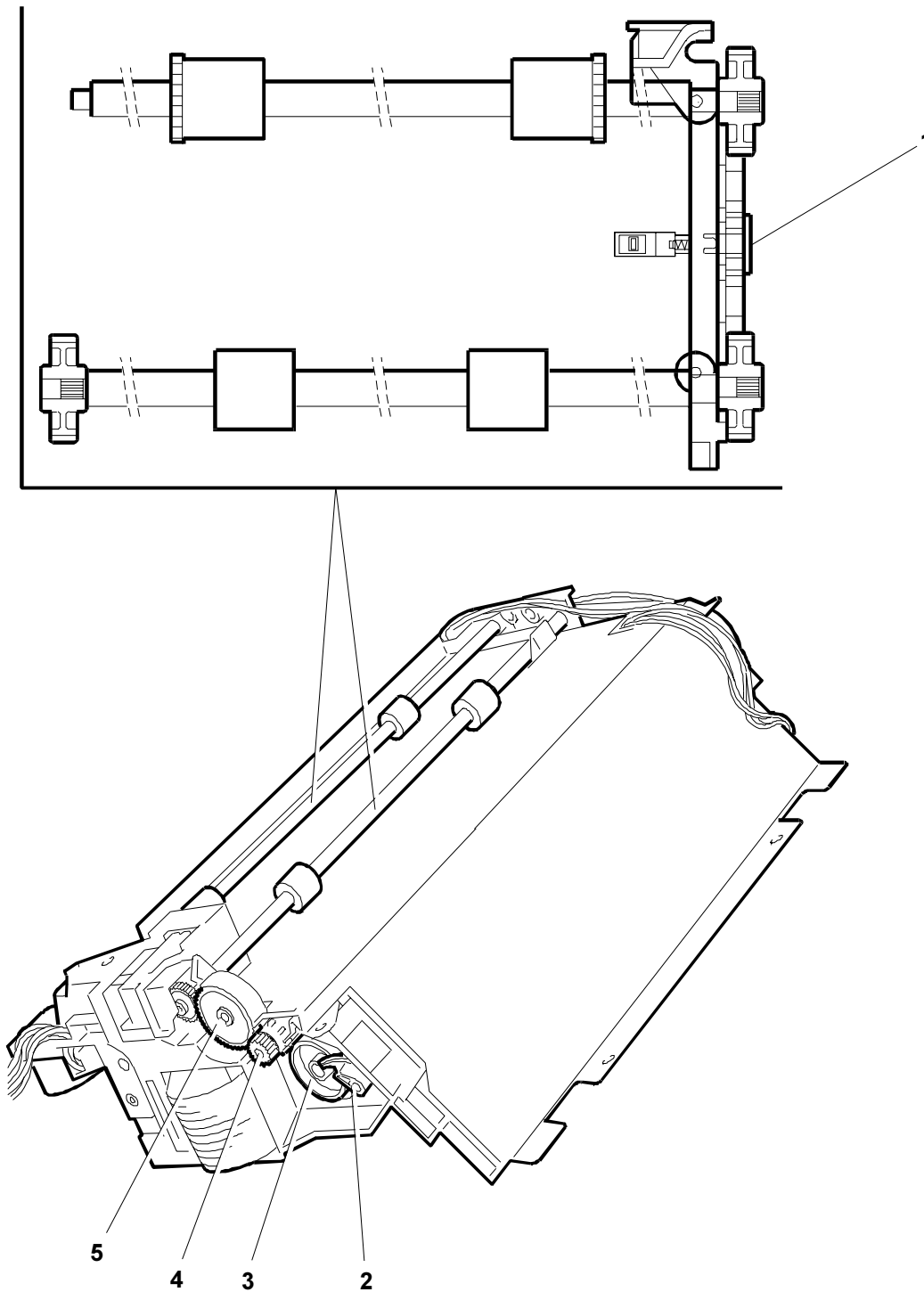




REF.	CODE	DESCRIPTION
1	022N00910	PAPER FEEDER ASSY
2	011N00394	PAPER INTRODUCTION LEVER
3	008N01713	INTRODUCTION CAM
4	007N00690	INTRODUCTION DRIVE GEAR
5	007N00691	GEAR T=52



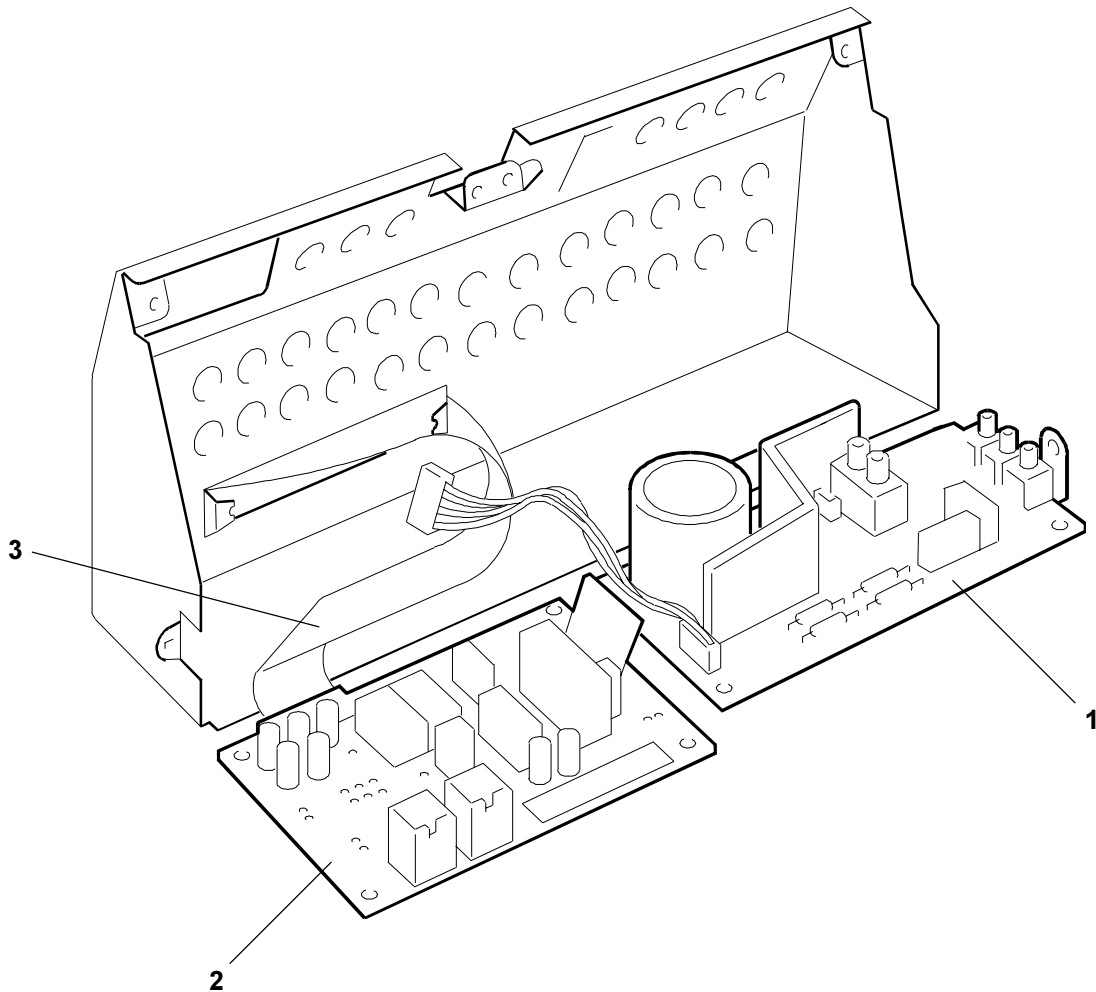
REF.	CODE	DESCRIPTION
1	022N00900	PAPER FEEDER ASSY
2	011N00394	PAPER INTRODUCTION LEVER
3	008N01713	INTRODUCTION CAM
4	007N00690	INTRODUCTION DRIVE GEAR
5	007N00691	GEAR T=52



# POWER SUPPLY AND NCU BOARD

DFC165  
DWC165c

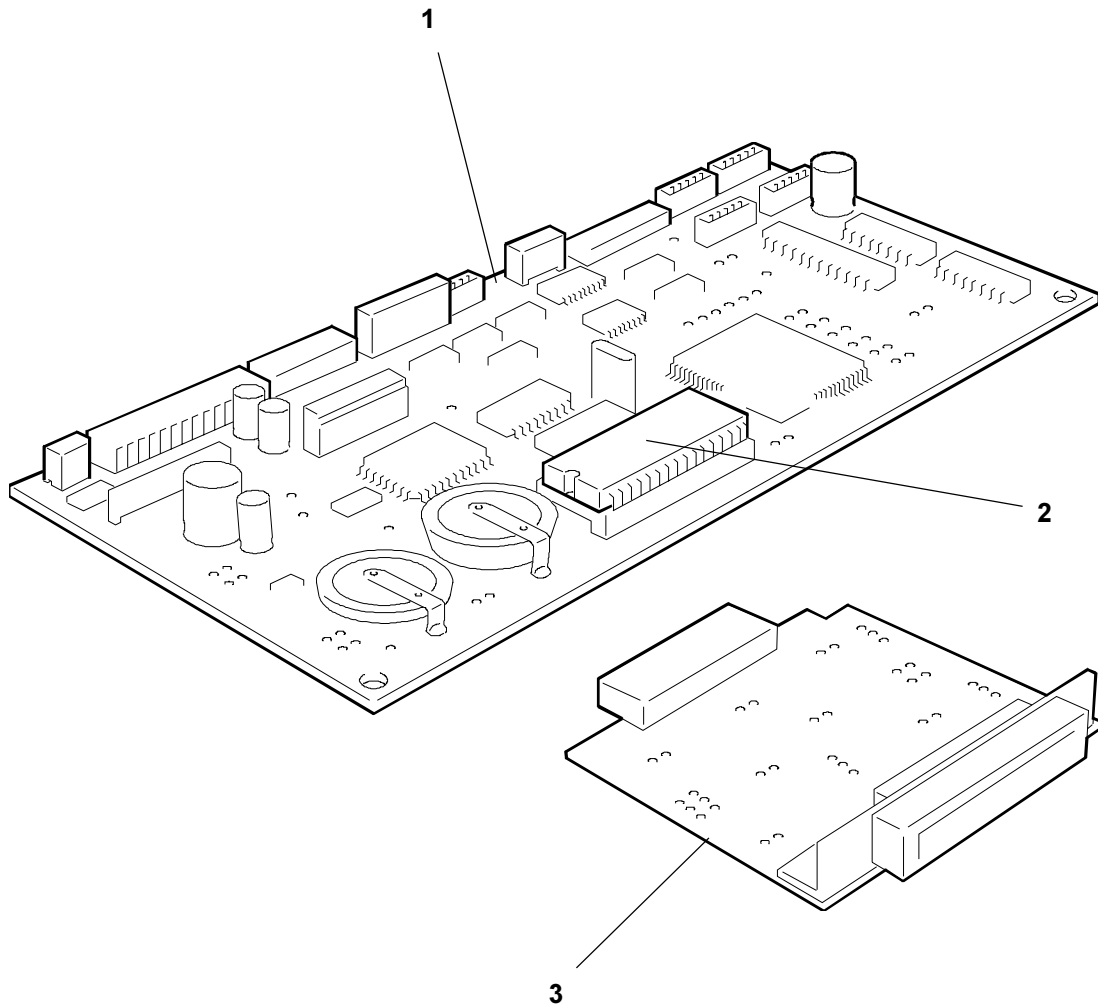
REF.	CODE	DESCRIPTION
1	140N05090	POWER SUPPLY BOARD 220V
2	140N05091	NCU BOARD ITALY
	140N05091	NCU BOARD UK
	140N05092	NCU BOARD GERMANY
	140N05094	NCU BOARD AUSTRIA
	140N05096	NCU BOARD SCANDINAVIA
	140N05097	NCU BOARD FRANCE
3	152N01600	NCU FLAT CABLE



# BOARDS

DFC165  
DWC165c

REF.	CODE	DESCRIPTION
1	140N05105 140N05098	MAIN BOARD (DFC165) MAIN BOARD (DWC165c)
2	006N00882 006N00879	FIRMWARE (DFC165) FIRMWARE (DWC165c)
3	140N05099	CENTRONICS INTERF. PCB (DWC165c)



## GENERAL CODES INDEX

CODE	PAGE	CODE	PAGE	CODE	PAGE
094N00201	7	130N00822	2		
022N00910	9	109N00386	5		
008N01713	9	127N00964	7		
008N01713	10	127N00963	7		
007N00690	9	022N00900	10		
007N00690	10	152N01613	4		
007N00691	9	006N00879	12		
007N00691	10	019N00408	7		
041N00188	8	038N00229	3		
006N00878	7	002N01519	2		
011N00394	9	002N01518	2		
011N00394	10	002N01516	2		
007N00685	6	030N00387	2		
007N00686	6	002N01520	3		
062N00138	5	110N00780	4		
062N00136	6	002N01517	2		
062N00135	6	140N05098	3		
062N00137	6	041N00819	8		
007N00684	6	140N05105	12		
130N00820	5				
002N01521	5				
007N00682	6				
007N00687	6				
007N00689	6				
054N00037	5				
022N00908	5				
130N00815	5				
130N00815	6				
121N00397	5				
022N00909	6				
128N00425	5				
140N05090	11				
140N05083	4				
140N05091	11				
140N05099	12				
140N05092	11				
140N05093	5				
140N05094	11				
140N05096	11				
140N05097	11				
030N00390	3				
030N00391	3				
123N00175	4				
006N00882	12				
032N00208	8				
130N00821	8				
023N00585	7				
020N00436	7				
020N00437	7				
127N00960	7				
127N00961	6				
127N00962	7				
110N00782	7				
152N01600	11				
152N01612	5				
127N00967	7				
127N00968	7				